

## CMM-3 & CMM-3K Zoning Panel Installation & Operating Instructions

### Product Data

- Single Stage gas and electric systems
- 2-3 zones
- 5-Year Warranty

### Specifications

- Construction: ABS Plastic
- Dimensions: 7 5/8" x 7 1/4" x 1 3/8"
- Voltage: 24 Volts AC, 50/60 Hz
- Operating Temperature: 0°- 120°
- Shipping/Storage Temperature: -20°- 140°
- Humidity Range: 5% - 95% Non-Condensing

### Kit Contents (CMM-3K)

- CMM-3
- CLAS (leaving air sensor)
- 24V Transformer

### Recommended Dampers

- CRDS – round damper (24V)
  - CZDS – rectangular, side mount motor (24V)
  - CZDB – rectangular, bottom mount motor (24V)
  - CSPRD – static pressure relief dampers
- 24V dampers are power close, spring open and are convertible to power open, spring close*

### Recommended Thermostats

- 1F78-151 (5+2 programming)
- 1F78-144 (non-programmable)
- 1F85-0471 (5+1+1,5+2,0 programming)
- 1F80-0471 (5+1+1,5+2,0 programming)
- 1F97-1277 (7, 5+1+1,0 programming)
- 1F95-1277 (7, 5+1+1,0 programming)
- 1F85RF-275 (5+1+1,5+2,0 programming) (wireless)

Terminal Destination	Description
G.....	Fan Relay
Y.....	Compressor Relay
R.....	Power for Heating/Cooling
W.....	Heat Relay
C.....	Common Wire

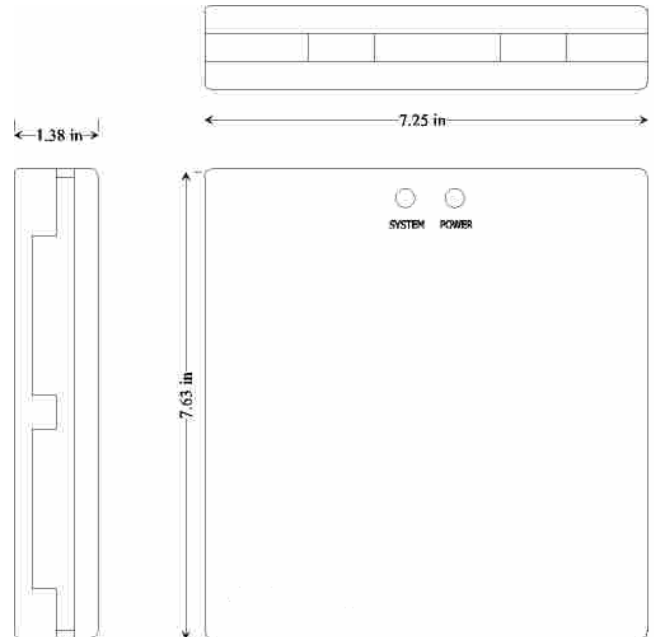

### CAUTION

To prevent electrical shock and/or equipment damage, disconnect electric power to system at main fuse or circuit breaker box until installation is complete

### SAVE THESE INSTRUCTIONS FOR FUTURE USE!

Failure to read and follow all instructions carefully before installing or operating this control could cause personal injury and/or property damage.

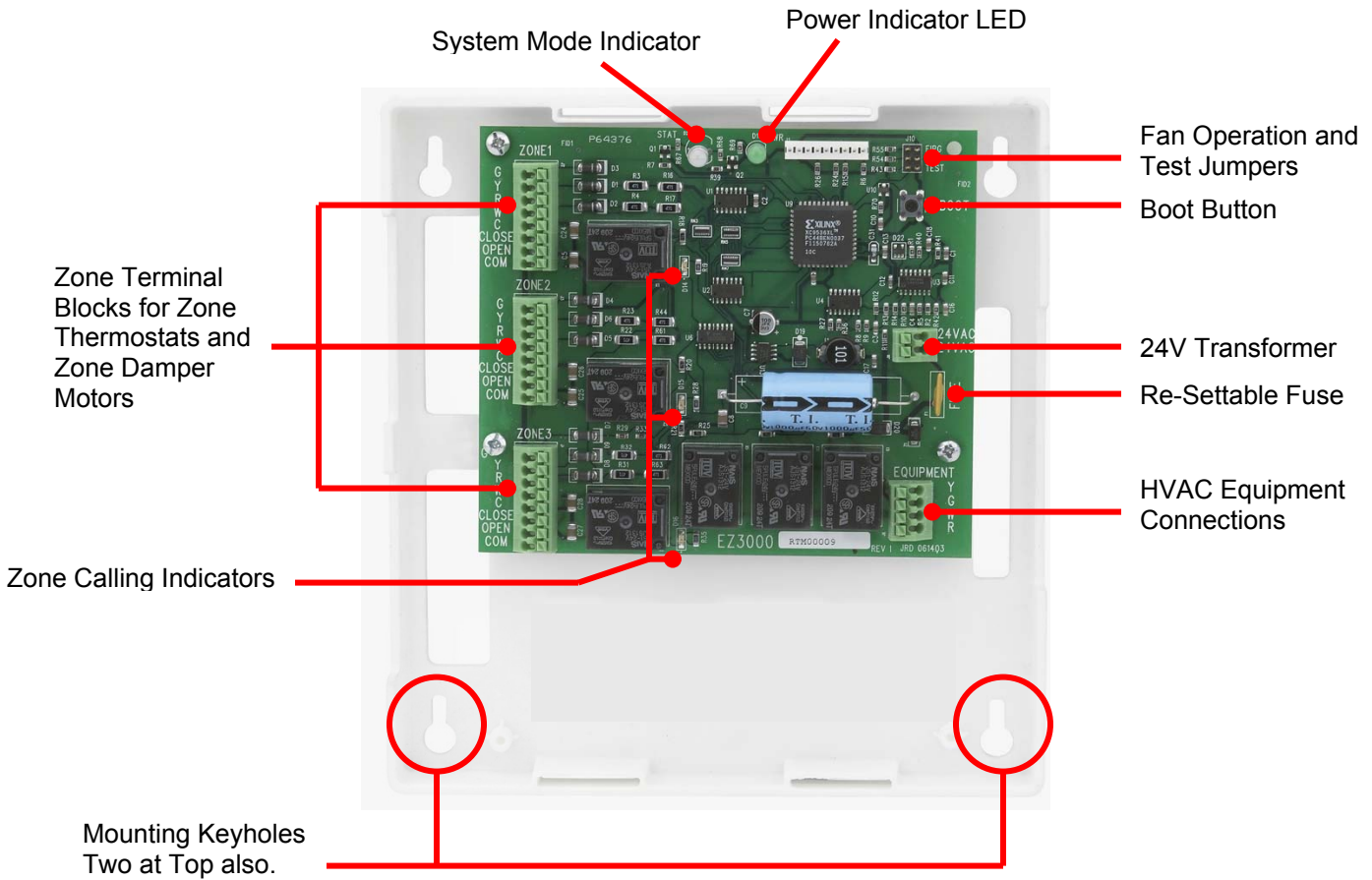

## Table of Contents

Installation	2
Operation	2-3
HVAC Equipment Set-up	3
Timers	3
Checkout	3
Wiring	3-4
Leaving Air Sensor	4
Troubleshooting	4

## **INSTALLATION**

The Comfort Plus™ Zoning System-3 is a two (2) and three (3) zone control panel for single stage heating only, cooling only or heating and cooling. The CMM-3 can control any single stage gas-oil-electric furnace, hydro-air heating and air conditioning. The CMM-3 panel is the central control panel where all zone dampers, zone thermostats, HVAC Equipment and power transformer are wired.

When installing the CMM-3 panel it is important to pick a central location where it is most convenient to bring all the wires. Most often this is at the furnace or air handler. It is often the most convenient location and closest to power, the HVAC unit controls and the zone dampers when typically located at or near the plenum.

The CMM-3 panel is made of sturdy ABS plastic and can be mounted to any flat surface. It is recommended that the panel be mounted to a wall or return plenum and NOT on the furnace or plenum where it will be in contact with the high temperatures. The panel can be located in an attic space or in an enclosed cabinet of a rooftop unit, provided the panel enclosed and not in direct exposure to the elements.

The cover easily removes from the case by pulling firmly and separating the cover from the case exposing the circuit board. There are 4 key-hole mounting points in each corner of the case. The case has openings in the rear of the case as well as the side for all wiring. Wiring can come from the back as well as the side in order to make a neat installation.

## **OPERATION**

The CMM-3 can controls single stage heating and cooling HVAC Equipment. The CMM-3 is compatible with any standard single stage thermostat and setback thermostats as well. The CMM-3 has various features that make installation and checkout very simple for all of the board's functionality.

The CMM-3's basic function is zone control. On a call for heating or cooling, the panel will accept the first call from any zone. Upon accepting this call the CMM-3 will keep open the damper(s) to the zone calling; close the damper(s) to those zones not calling, activate the needed HVAC controls for heating or cooling, whichever is being called and not accept any calls for the opposite mode.

Any calls for the opposite mode will be locked out until the initial mode is either satisfied or a period of time has elapsed that is sufficient for the first mode to satisfy, a maximum of 20 minutes. A Patent Pending sequence determines the time the unit has been running or needs to continue to run in order to adequately provide conditioning for each mode. If a particular mode has already been calling for 20 minutes or longer and an opposite call comes in the CMM-3 will immediately drop the mode, enter the purge mode in order to dissipate the conditioned air into the zones calling before switching over to provide the new conditioning call to its zones.

## PURGE TIME

Once a call is satisfied the CMM-3 drops the call for the heating or cooling unit controls, whichever was calling and hold the damper(s) to the zone(s) that were last calling during the Purge Mode. The Purge mode is nominally 2 minutes and allows the excess conditioned air in the plenum to be distributed only to the zone(s) that were last calling. This eliminates the problem of overshooting the temperature in the satisfied zones.

During the Purge mode the panel can be set to keep the Fan running during Purge or to let the fan control in the HVAC unit to control the fan. By using the FIPG (Fan On-In Purge) jumper, on the top right corner of the control panel, this keeps the fan running until the Purge mode is over. This mode avoids the fan shutting off during the Purge mode and coming back on when another zone may be on constant fan after the Purge Mode is over. This may be more often used in commercial applications for continuous air circulation (CAC). In residential applications the fan remaining on, especially in heating, may be drafty and objectionable.

Once all zone thermostats are satisfied for heating and cooling, the CMM-3 can now accept Fan calls allowing Continuous Air Circulation(CAC) in those zones where the thermostat's Fan Switch is set to ON. These zone dampers will be OPEN while the dampers to the zones where the Fan Switch is set to AUTO will be CLOSED.

When all zone thermostats are satisfied for both Heating and Cooling, and all Fan switches are set to AUTO position, the HVAC unit will be off and all zone dampers will return to a normally open position. Once a zone calls for heating, cooling or fan, the dampers to the calling zones remain open and the dampers to the zones not calling will close.

## HVAC EQUIPMENT SET UP

The CMM-3 is factory set for conventional fossil fuel (oil or gas) single stage heating and cooling. The panel only needs to be configured when using with a conventional electric furnace or hydro-air system in order to bring the fan on with a call for heat.

By using the FIH (Fan On-In Heat) jumper, located on the upper right corner of the board, this allows the Fan to be activated with a call for heat. Once the heat call is satisfied the fan will shut off as well, as long as the FIPG jumper is off as well.

## CHANGEOVER TIMER

Whenever a call is made for either heating or cooling, the changeover timer is activated in order to track the amount of time heating or cooling is on. When an opposite call is made after a first call is existing the changeover timer calculates the amount of time the unit has already been supplying the first mode in order to determine how long it will hold off the opposite call. If an opposite call is made shortly after the first call, the opposite call may be held off for as much as 20 minutes. If the first call or subsequent calls for the first call mode has had that mode operating for up to 20 minutes already and an opposite call comes in after 20 minutes, the changeover timer will immediately recognize the opposite call, shutting off the current mode, enter the purge mode and automatically switch to the opposite mode.

The longer a call has been running up to 20 minutes, the shorter the wait time will be for an opposite call. If a call is over 20 minutes and an opposite call is made the changeover will be immediate following

the purge time. This intelligent changeover timing makes the CMM-3 unique to any other zoning system.

## CHECKOUT

The CMM-3 has unique features that simplify the checkout of the system and has LED readouts that constantly indicate the system operation. Once 24 Volt Power is applied to the panel the Green Power LED will illuminate. This will stay illuminated constantly when power is applied.

The System LED will provide several different indications based upon color and if it is flashing.

Heat ON – RED  
Heat Overlimit – RED Flashing  
Cool ON – GREEN  
Cool Overlimit – Green Flashing  
FAN ON – AMBER  
PURGE – AMBER Flashing

Each zone has its own small Green indicator LED next to each zone relay. This light is lit when the specific zoning is calling for the mode shown on the System LED.

## WIRING

The CMM-3 is very simple to wire and requires only a minimum number of connections. The CMM-3 terminal blocks are screw-less and all wires can easily be pushed into their respective terminal by de-pressing the button for each point and releasing once the wire is seated. To remove the wire, just press its button again and remove the wire.

**Zone Dampers** – The CMM-3 can power any 24VAC damper, either 2 wire or 3 wire. See specific wiring instructions with the damper and inside panel cover.

**Zone Thermostats** – The thermostats wiring will for single stage can be four or five wire. The fifth wire being the C-Common terminal for 24 Volt powered thermostats. There are 5 terminals on the CMM-3 for each thermostat, marked Y-G-R-W-C. This wiring is shown on Wiring Diagram 1 for single stage thermostats.

**HVAC Equipment** – The HVAC equipment will follow Wiring Diagram 2 for Single Stage Systems.

**Transformer** – A separate 24 Volt AC, 40VA Transformer is recommended to power the control panel and dampers. Often the transformer on the HVAC unit only has enough power for its own controls. Therefore it is recommended a separate transformer be used to power this panel and the dampers wired to it.

## WIRING DIAGRAM 1 – Zone Thermostat and Damper

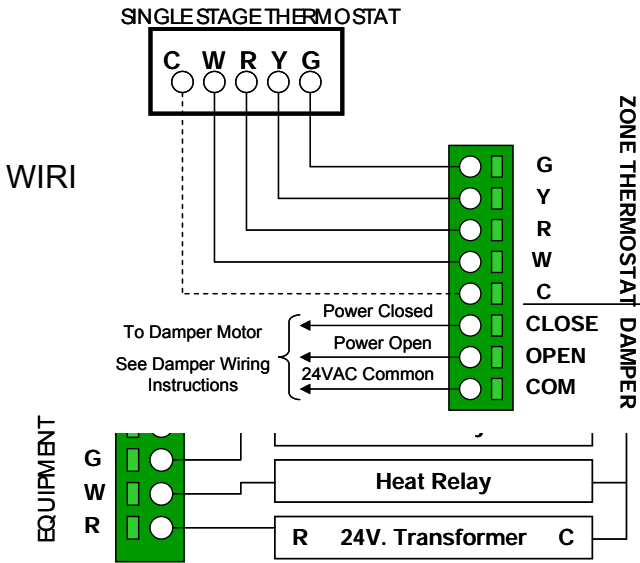

## WIRING DIAGRAM 3 – 24 Volt AC, 40 VA Transformer

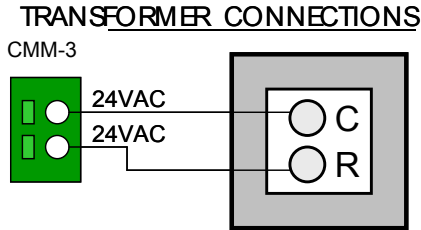

### LEAVING AIR SENSOR (CLAS)

The Leaving Air Sensor, Model CLAS, is a remote sensor that is located in the supply air duct to sense the leaving air temperature of the HVAC Unit. The CLAS is a high limit protection for the heating and a low limit protection for the cooling. When zoning, the airflow through the HVAC Unit is critical. The CLAS protects the equipment in low air flow situations as well as when by-pass air is being directed back into the return air duct.

The heating limit is fixed at 180°F. The cooling limit is fixed at 40°F. When the CLAS senses heating above its set point, or cooling below its set point, the CMM3 will drop both stages of heating or cooling. The CLAS must sense a 10°F fall for heating or rise for cooling before re-activating the first stages of heating or cooling. If two stage heating or cooling is being used the second stage timer will start again once the first stage is re-activated.

The CLAS requires 2 wires from the sensor to the LAT terminals on the CMM3 panel. The CLAS probe can also be adjusted for length by loosening the end nut and sliding the probe thru the mounting plate in order for the probe to pass through any duct insulation

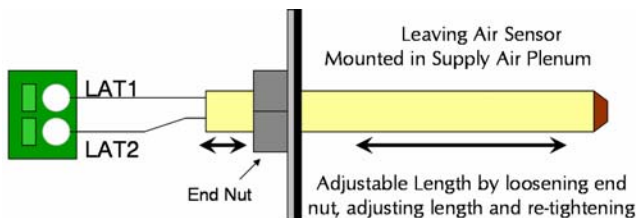

**NOTE:** If the CLAS is not used, the NO SENSOR jumper located just above the LAT terminals must be on the pins.

### TROUBLESHOOTING

The CMM-3 is a very simple control to troubleshoot, especially with the LED indicators. The only other device needed is a simple Volt/Ohm meter.

The first check is for 24VAC Power to the panel. When there is power the Green Power LED will be lit. If not check the transformer and the power supply to it.

Almost all problems can be traced to an external component or wiring to the CMM-3. While the CMM-3 has been designed to operate under extreme voltage conditions and is fuse protected, like any computer the micro-processor can hang up and not operate properly. For these instances a BOOT button has been installed that re-boots the micro-processor just like your computer. Pressing this button for a few seconds and then release it will allow the micro-processor to re-boot and in most all cases eliminate the problem. If not the following procedure can help isolate the problem.

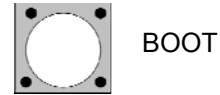

#### Zone(s) Not Calling

Each zone has a Green LED next to the zone relay when it is calling. The LED being lit shows that the call is being recognized by the CMM-3. If a zone is supposed to be calling and the Zone LED is not on, check for 24VAC across the thermostat terminal C and the Y, if a Cool call, W if a Heat Call, or G if a Fan call. If there is no voltage here at the panel the panel is not getting the signal from the thermostat. The problem is mis-wiring, a broken wire or a problem in the thermostat. To check the zone on the panel, place jumper from R to Y to simulate a Cool call, R to W to simulate a Heat call, or R to G to simulate a Fan call. By jumpering these terminals the zone call LED will activate.

#### Zone(s) Will Not Shut Off

If a zone will not stop calling, the Zone LED should still be on. Depending on the call disconnect the Y, W or G wire from the terminal strip. The zone will drop out. Check the thermostat wiring for a mis-wiring or short that keeps the zone calling.

#### Damper Motor Checkout

To checkout the dampers, the panel provides 24VAC to the COM and OPEN terminal when the damper is to be open and 24VAC to COM and CLOSE when the damper is to be CLOSED. When any zone is calling and its Green LED is ON, there is 24VAC across COM and OPEN. The only time a damper will close is when another zone is calling and its zone is not calling. In this instance there will be 24VAC across COM and CLOSE terminals.

Refer to the instructions with each damper for their individual checkout.

White  
Rodgers

EMERSON  
Climate Technologies

St. Louis, Missouri Markham, Ontario  
www.white-rodders.com