

MODEL	REF	CUSTOMER	HP	VOLTS	AMPS	HZ	RPM	ROTATION	CUSTOMER PN	DESCRIPTION / REMARKS
K55HXC MV-1654	C37129	WHOLESALE HAC	1	208-230/460	6.1/3.1	60	1125	CCW. LEAD END REV.	1376	K55 HUB MTD, BALL BRG., OPEN

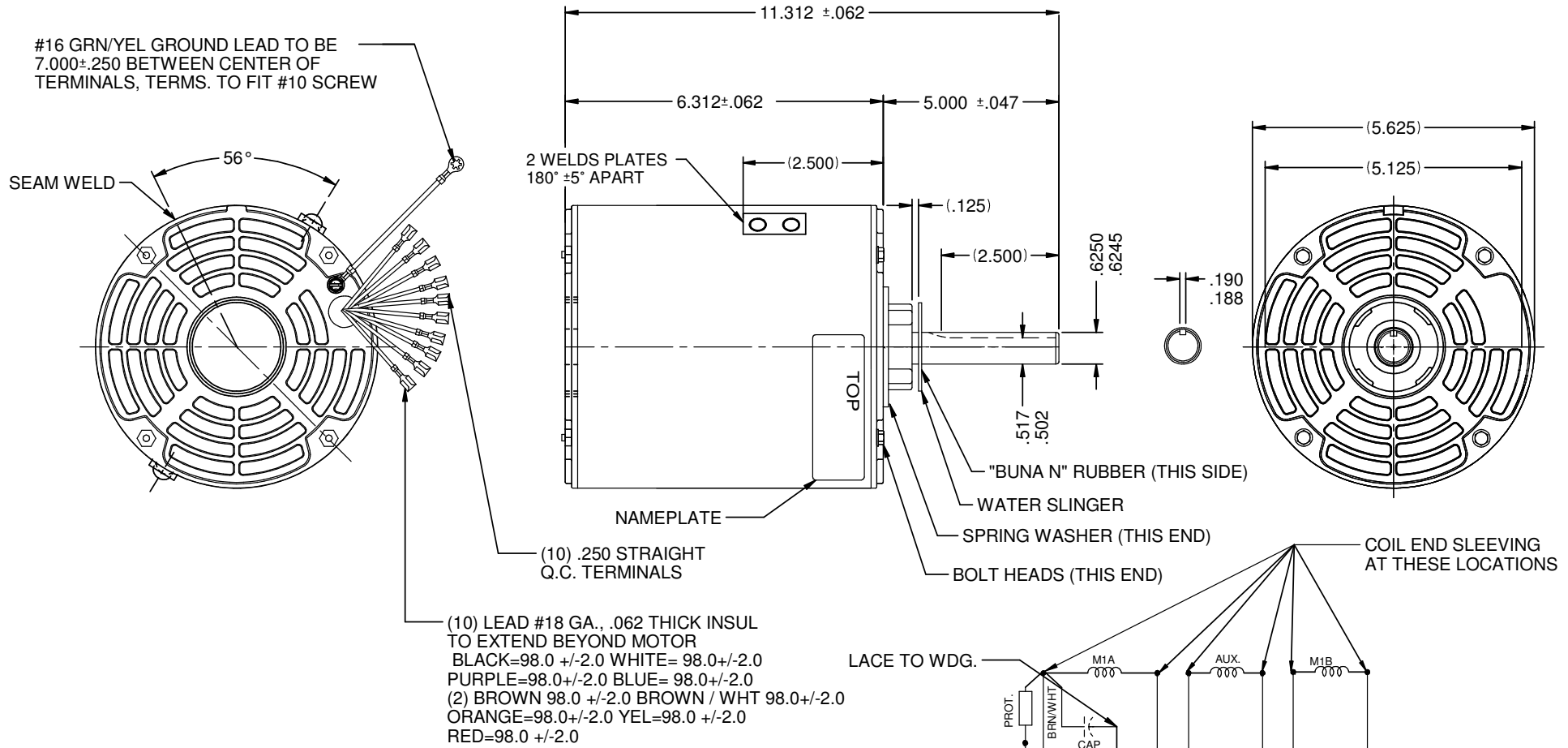

NIDEC MOTOR CORPORATION 17-Mar-16

TO REVERSE ROTATION INTERCHANGE BLACK AND RED LEADS. REFER TO S.E.I.M. 24-1

CREATED DRAWING.	REVISION RECORD FOR: ECO-E25136
ISSUED BY: G. ISASSI	ENGINEER APPROVED: A. VILLANUEVA

DIMENSIONS ARE FOR REFERENCE ONLY  
UNLESS TOLERANCE IS SPECIFIED

<b>NIDEC MOTOR CORPORATION</b>			
INFORMATION DISCLOSED ON THIS DOCUMENT IS CONSIDERED PROPRIETARY AND SHALL NOT BE REPRODUCED OR DISCLOSED WITHOUT WRITTEN CONSENT OF NIDEC MOTOR CORPORATION			
TITLE		CODE	REVISION DATE: 18-MAR-16
CUSTOMER DETAIL DRAWING		V02	18-MAR-16
ITEM NO.	REV	SHEET NUMBER	DWG SIZE
810457	--	1 OF 3	B

V02\_NMCB (MAR-2014)

SOLIDEDGE