

Submitted by: _____

Date: _____

Stamped Face Supply

Side Wall / Ceiling

Model:

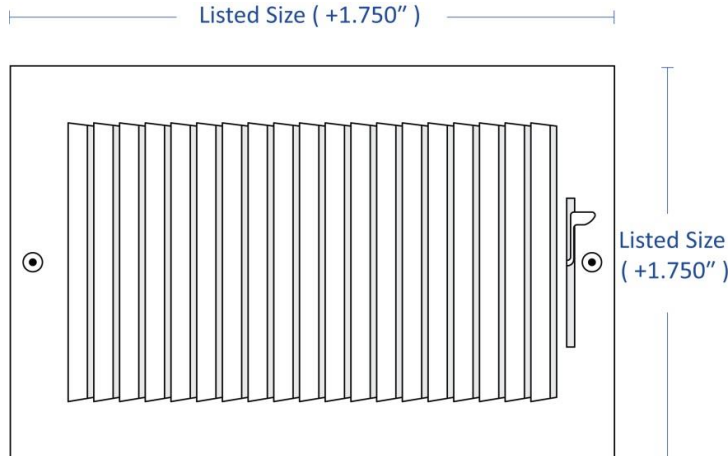

Available Options

- 1 Way Down
- 1 Way Left
- 1 Way Right
- Multi-Shutter Damper
- Opposed Blade Damper

Multi-Shutter Damper

1 7/16"

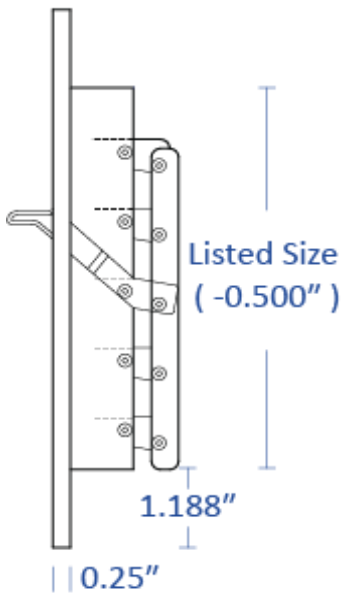

Opposed Blade Damper

1 11/16"

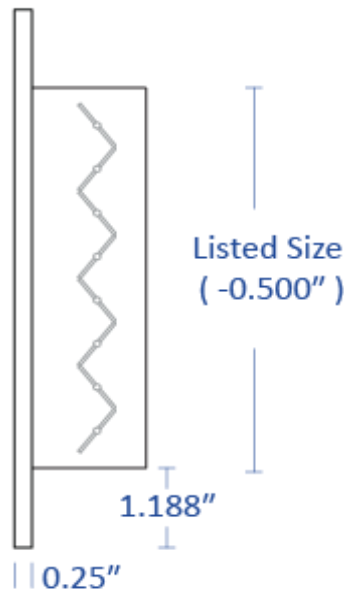

Model Features

- Stamped 1 way air pattern
- 1/2" fin spacing with 45° blade angle
- Durable white powder coat finish

Material: Steel

Face: Stamped

Model Size:

Project Name: _____

Architect: _____

Project Location: _____

Engineer: _____

Contractor: _____