

LABEL	UPCA BARCODE NUMBER
I-BOX	817506021701
SUB-BOX	817506021718
MASTER BOX	817506021725
FULL PALLET	817506021732

I-BOX	SUB BOX	OVERPACK
BMF-8-6A	BEST FIT	BEST FIT

**NOTES: UNLESS OTHERWISE SPECIFIED**

- 1 HARTLAND CONTROLS PART NUMBER TO APPEAR ON PRODUCT LABEL WITHOUT CUSTOMER SUFFIX.
- 2 COLORED LOGO TO APPEAR ONLY ON INDIVIDUAL BOX. LOGO TO BE AS SHOWN WITH BLACK LETTERING.
- 3 COUNTRY OF ORIGIN TO ONLY APPEAR ON PRODUCT LABEL.
- 4 BARCODE TYPE TO BE UPCA BARCODE .

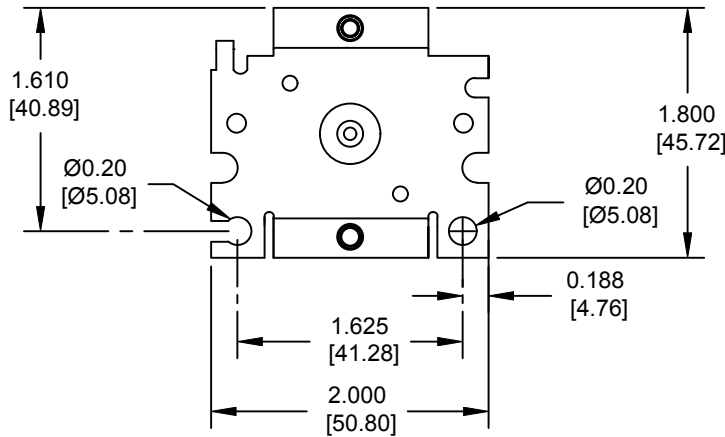
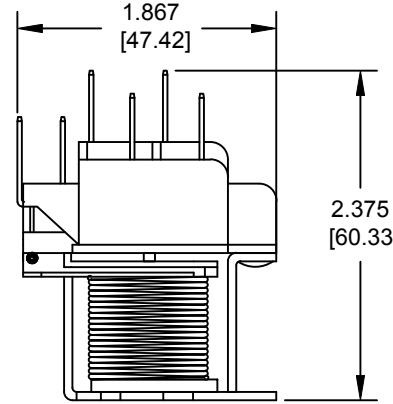
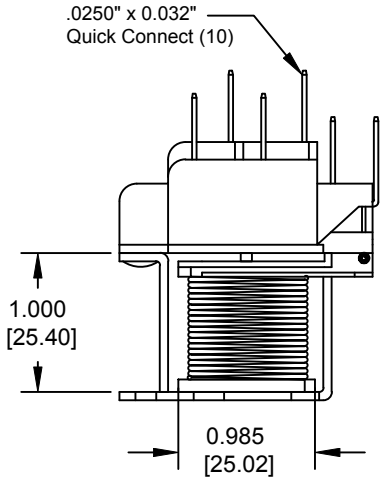
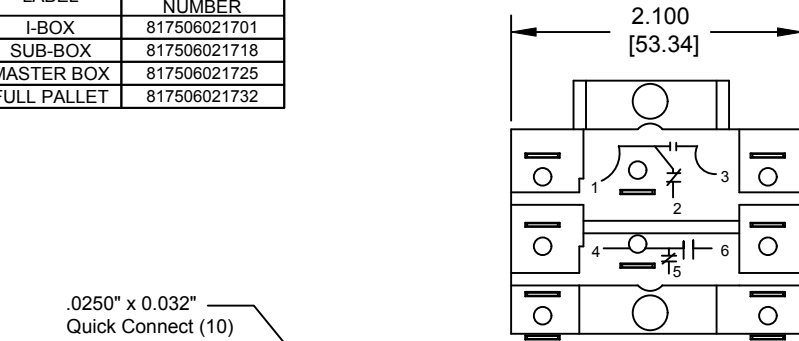

**TP-90340**  
 3/4 H.P. 120 VAC  
 15 A, 277 VAC 12.5A, 480 VAC RES  
 12 FLA, 60 LRA, 120 VAC  
 8 FLA, 48 LRA, 277 VAC  
 3FLA, 18 LRA, 480 VAC  
 3FLA, 14 LRA, 600 VAC  
 COIL 24 VAC 50/60 HZ  
 HERM. REFRIG. COMP.  
 HCRY62CQ1AA  
 MADE IN CHINA  
 XWVWYY

PRODUCT LABEL - 1003284  
 (1.00"[25.4] X .75"[19.05])

PMS 361C (GREEN)



INDIVIDUAL BOX LABEL - 1003297  
 (2.00"[50.8] X 3.50"[88.9])

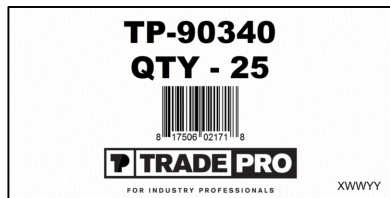

SUB BOX LABEL - 1004882  
 (4.00"[101.6] X 2.00"[50.8])

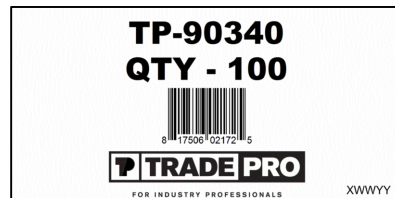

MASTER BOX LABEL - 1004882  
 (4.00"[101.6] X 2.00"[50.8])

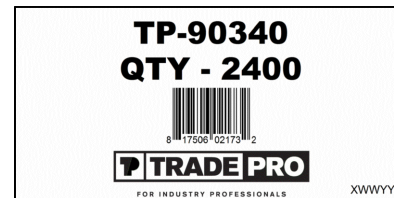

FULL PALLET LABEL - 1004882  
 (4.00"[101.6] X 2.00"[50.8])

REV.	DESCRIPTION	ECN	DWN	APVD	APVD DATE
J	ADDED CHECK DIGIT TO UPCA BARCODE NUMBER TABLE	04084	AJS	BSJ	9/23/16
I	REVISED CUSTOMER NUMBER ON PRODUCT LABEL	04068	BSJ	MM	9/19/16
H	ADDED FULL PALLET LABEL AND REVISED BARCODES TO UPCA FORMATS.	04052	AJS	BSJ	8/19/16
G	SUB BOX AND MASTER BOX LABELS WERE 1001251	02203	EI	BSJ	5/31/13
F	REVISED LOGO ON MASTER BOX LABEL	01968	EI	BSJ	2/7/13
E	REVISED BOTTOM VIEW	01906	EI	BSJ	1/4/13
D	ADDED SUB BOX LABEL. REVISED PACKAGING.	01803	EI	BSJ	11/8/12
C	REVISED LABELS	01285	EI	ACE	3/2/12
B	REVISED I-BOX LABEL	00234	SV	ACE	4-1-10
A	ISSUED	00171	SV	ACE	12-16-09

**Hartland Controls LLC**  
 807 Antec Rd.  
 Rock Falls, IL 61071

DRN. BY	DRN. DATE	CHECKED BY	CHECKED DATE
SV	12-14-09	ACE	12-16-09

DESC. RELAY, TYPE 6  
 PART NO. HCRY62CQ1AA217