

PACKAGE ELECTRIC COOLING UNIT R-410A SINGLE PACKAGE ROOFTOP 3 – 5 TONS (1 & 3-Phase)

BUILT TO LAST, EASY TO INSTALL AND SERVICE

- ASHRAE 90.1 energy compliant efficiency levels
- Single-stage cooling capacity control on all models
- Rated in accordance with ARI Standard 210/240 (036-060 sizes)
- SEER's up to 14.1, EER's up to 12.0
- Exclusive non-corrosive composite condensate pan in accordance with ASHRAE 62 Standard, sloping design; side or center drain
- Convertible from vertical to horizontal airflow for slab mounting
- Copper tube aluminum fin coils with optional corrosion resistant coils
- Pre-painted exterior panels and tested to 500 hours salt spray protection
- Fixed orifice refrigerant metering system
- Cooling operating range up to 115F (46C) and down to 25F (-4C)
- Solid-state control board and easy access terminal board
- Refrigerant filter drier and accumulator on each refrigerant circuit
- Automatic changeover when used with auto-changeover thermostat
- Rated in accordance with AHRI Standards 210/240 (036-060)
- Designed in accordance with Underwriters' Laboratories Std 1995
- Listed by UL and UL, Canada

MAINTENANCE FEATURES

- Access panels with easy grip handles
- Innovative, easy starting, no strip screw features on unit access panels.
- Two-inch disposable return air filters with tool-less filter access door
- Belt drive evaporator-fan motor and pulley combinations available on all sizes to meet any application
- Direct Drive ECM - indoor motor is standard with optional belt drive systems
- Advanced terminal board facilitating simple safety circuit troubleshooting and simplified control box arrangement

INSTALLATION FEATURES

- Thru-the-bottom power entry capability standard
- Single point electric connections
- Full perimeter base rail with built-in rigging adapters & fork truck slots



Use of the AHRI Certified TM Mark indicates a manufacturer's participation in the program. For verification of certification for individual products, go to www.ahridirectory.org.



RELIABILITY FEATURES

- Scroll compressors with internal line break overload protection
- 24-volt control circuit protected with resettable circuit breaker
- Permanently lubricated evaporator-fan motor
- Totally enclosed condenser motors with permanently lubricated bearings
- Low pressure, freeze protection, and high-pressure switches

FACTORY OPTIONS INCLUDING BUT NOT LIMITED TO:

- Two position damper options
- Disconnect and convenience outlet options
- Supply air smoke detector and CO2 sensor options
- Multiple indoor fan motors for expanded airflow capability(3ph)
- Corrosion resistant coil options for evaporator and condenser
- Accessory electric heat (field-installed option only)
- Integrated economizer system. Standard and Ultra Low leak versions available.

LIMITED WARRANTY *

- 5 year electric heater parts
- 5 year compressor limited warranty
- 1 year parts limited warranty

* See warranty certificate for complete details and restrictions

UNIT PERFORMANCE DATA							
BASE MODEL	Nominal Tons	Net Cap. (Btuh)	SEER	EER	Total Power (kW)	Unit Dimensions H x W x L	Unit Weight lbs (kg)
RAX036*0XA0AAA	3	35,400	14.00	12.00	3.0	33-3/8 x 46-3/4 x 74-3/8 (847 x 1187 x 1888)	445 (201)
RAX048*0XA0AAA	4	47,500	14.00	12.00	4.0	33-3/8 x 46-3/4 x 74-3/8 (847 x 1187 x 1888)	499 (226)
RAX060*0XA0AAA	5	58,500	14.10	12.00	4.9	41-3/8 x 46-3/4 x 74-3/8 (1051 x 1187 x 1888)	552 (250)

* Indicates Unit voltage: K = 208/230-1-60, H = 208/230-3-60, L = 460-3-60, S = 575-3-60

NOTE: BASE MODEL NUMBERS LISTED. SEE MODEL NOMENCLATURE LISTING FOR ADDITIONAL OPTIONS

MODEL NUMBER NOMENCLATURE

MODEL SERIES	R	A	X	0	6	0	L	O	A	B	0	A	A	A
Position Number	1	2	3	4	5	6	7	8	9	10	11	12	13	14
R = Rooftop														
A = Air Conditioning Type														
X = ASHRAE 90.1 Standard Efficiency														
036 = 3 Tons 048 = 4 Tons 060 = 5 Tons Nominal Cooling Capacity														
K = 208/230-1-60 H = 208/230-3-60 L = 460-3-60 S = 575-3-60 Voltage														
O = No Heat Heating Capacity														
X = Standard Motor Direct Drive B = High Static Motor / Drive – Belt Drive C = Medium Static Motor / Drive – Belt Drive H = High Static Motor / Drive – Belt Drive with Hot Gas ReHeat Motor Option (Indoor Fan)														
A = None B = Economizer w/Bara-relief, OA Temp sensor E = Economizer w/Bara-relief + CO2 Sensor, OA Temp sensor H = Economizer w/Bara-relief, enthalpy sensor L = Economizer w/Bara-relief + CO2 Sensor, enthalpy sensor U = Temp Ultra Low Leak Economizer w/Bara-relief W = Enthalpy Ultra Low Leak Economizer w/Bara-relief P = 2-Position damper Outdoor Air Options / Control ¹														
0A = No Options AT = Non-powered 115v C.O. 4B = Non-Fused Disconnect BR = Supply Air Smoke Detector AA = Easy Access Hinged Panels Factory Installed Options														
A = Aluminum / Copper Cond & Evap Coil B = Precoat Alum/Copper Cond with Alum / Copper Evap (3 phase only) C = E-Coated Alum/Copper Cond with Alum / Copper Evap (3 phase only) D = E-Coated Alum / Copper Cond & Evap (3 phase only) E = Copper/Copper Cond & Alum/Copper Evap (3 phase only) F = Copper/Copper Cond & Evap (3 phase only) Condenser / Evaporator Coil Configuration														
A = Economizer controls for EconoMiZerIV B = Economizer controls for EconoMiZerX Motor Type Option														

NOTE: Factory installed options are NOT available on single phase models. This includes economizers and 2 position dampers.

¹ A combinations of FIOPS are available.

Table 1 – FACTORY-INSTALLED OPTIONS AND FIELD-INSTALLED ACCESSORIES

CATEGORY	ITEM	FACTORY INSTALLED OPTION	FIELD INSTALLED ACCESSORY
Cabinet	Thru-the-base electrical connections		X
	Hinged Access Panels	X	
Coil Options	Cu/Cu indoor and/or outdoor coils ⁵	X	
	Pre-coated outdoor coils ⁵	X	
	Premium, E-coated outdoor coils ⁵	X	
Condenser Protection	Condenser coil hail guard (louvered design) ⁵	X	X
Controls	Thermostats, temperature sensors, and subbases		X
	Smoke detector (supply air)	X	
	Time Guard II compressor delay control circuit		X
	Phase Monitor		X
Economizers & Outdoor Air Dampers	EconoMi\$er IV (for electro-mechanical controlled – Non FDD (Standard air leak damper models) ^{5, 6}	X	X
	Motorized 2 position outdoor-air damper ⁵	X	X
	Manual outdoor-air damper (25% and 50%)		X
	Barometric relief ¹	X	X
	Power exhaust		X
Economizer Sensors & IAQ Devices	EconoMi\$er X for electro-mechanical controls, complies with FDD (Standard and Ultra Low Leak air damper models) ^{5, 6}	X	X
	Single dry bulb temperature sensors ²	X	X
	Differential dry bulb temperature sensors ²		X
	Single enthalpy sensors ²	X	X
	Differential enthalpy sensors ²		X
Electric Heat	CO ₂ sensor (wall, duct, or unit mounted) ²	X	X
	Electric Resistance Heaters		X
Indoor Motor & Drive	Single Point Kit		X
	Multiple motor and drive packages	X	
Low Ambient Control	Winter start kit ³		X
	Motormaster head pressure controller ³		X
Power Options	Convenience outlet (unpowered)	X	
	Non-fused disconnect ⁴	X	
Roof Curbs	Roof curb 14-in (356mm)		X
	Roof curb 24-in (610mm)		X

NOTES:

1. Included with economizer.
2. Sensors for optimizing economizer.
3. See application data for assistance.
4. Available on units with MOCP's of 80 amps or less.
5. Not available as factory installed option on single phase (208/230/1/60) models. Use field-installed accessory where available.
6. FDD –(Fault Detection and Diagnostic) capability per California Title 24 section 120.2

FACTORY OPTIONS AND/OR ACCESSORIES

Economizer

Economizers save energy, money and improve comfort levels in the conditioned space. They bring in fresh, outside air for ventilation; and provide cool outside air to cool your building. This also is the preferred method of low ambient cooling. When integrated with CO₂ sensors, economizers can provide even more savings by coupling the ventilation air to only that amount required based on space occupancy. Economizers are available, installed and tested by the factory, with either enthalpy or temperature dry-bulb inputs. There are also models for electromechanical and direct digital controllers. Additional sensors are available as accessories to optimize the economizer. Economizers include gravity controlled barometric relief that helps equalize building pressure and ambient air pressures. This can be a cost effective solution to prevent building pressurization. Economizers are available in Ultra Low Leak and standard low leak versions.

CO₂ Sensor

Improves productivity and saves money by working with the economizer to intake only the correct amount of outside air for ventilation. As occupants fill your building, the CO₂ sensor detects their presence through increasing CO₂ levels, and opens the economizer appropriately.

When the occupants leave, the CO₂ levels decrease, and the sensor appropriately closes the economizer. This intelligent control of the ventilation air, called Demand Control Ventilation (DCV) reduces the overall load on the rooftop, saving money.

Smoke Detectors

Trust the experts. Smoke detectors make your application safer and your job easier. ICP smoke detectors immediately shut down the rooftop unit when smoke is detected. They are available, installed by the factory, for supply air.

Louvered Hail Guards

Sleek, louvered panels protect the condenser coil from hail damage, foreign objects, and incidental contact.

Convenience Outlet (un-powered)

Reduce service and/or installation costs by including a convenience outlet in your specification. ICP will install this service feature at our factory. Provides a convenient, 15 amp, 115v GFCI receptacle with "Wet in Use" cover. The "powered" option allows the installer to power the outlet from the line side of the disconnect or load side as required by code. The "unpowered" option is to be powered from a separate 115/120v power source.

Non-fused Disconnect

This OSHA-compliant, factory-installed, safety switch allows a service technician to locally secure power to the rooftop.

Power Exhaust with Barometric Relief

Superior internal building pressure control. This field-installed accessory may eliminate the need for costly, external pressure control fans.

Time Guard II Control Circuit

This accessory protects your compressor by preventing short-cycling in the event of some other failure, prevents the compressor from restarting for 30 seconds after stopping.

Filter or Fan Status Switches

Use these differential pressure switches to detect a filter clog or indoor fan motor failure. When used in conjunction with a compatible unit controller/thermostat, the switches will activate an alarm to warn the appropriate personnel.

Motorized 2-Position Damper

The ICP 2-position, motorized outdoor air damper admits up to 100% outside air. Using reliable, gear-driven technology, the 2-position damper opens to allow ventilation air and closes when the rooftop stops, stopping unwanted infiltration.

Manual OA Damper

Manual outdoor air dampers are an economical way to bring in ventilation air. The dampers are available in 25% and 50% versions.

Optional Hot Gas ReHeat Dehumidification System

ICP's Hot Gas ReHeat dehumidification system is an all-inclusive factory-installed option that can be ordered with any 3 Phase 036-060 rooftop unit.

This system expands the envelope of operation of ICP's rooftop products to provide unprecedented flexibility to meet year-round comfort conditions.

The Hot Gas ReHeat dehumidification system has the industry's only dual dehumidification mode setting. The Hot Gas ReHeat system includes two new modes of operation.

The RAX036-060 rooftop coupled with the Hot Gas ReHeat system is capable of operating in normal design cooling mode, subcooling mode, and hot gas reheat mode. Normal design cooling mode is when the unit will operate under its normal sequence of operation by cycling compressors to maintain comfort conditions.

FACTORY OPTIONS AND/OR ACCESSORIES (cont.)

Optional Hot Gas ReHeat Dehumidification System (cont.)

Subcooling mode will operate to satisfy part load type conditions when the space requires combined sensible and a higher proportion of latent load control. Hot Gas Reheat mode will operate when outdoor temperatures diminish and the need for latent capacity is required for sole humidity control. Hot Gas Reheat mode will provide neutral air for maximum dehumidification operation.

Motormaster Head Pressure Controller

The Motormaster motor controller is a low ambient, head pressure controller kit that is designed to maintain the unit's condenser head pressure during periods of low ambient cooling operation. This device should be used as an alternative to economizer free cooling when economizer usage is either not appropriate or desired. The Motormaster will either cycle the outdoor fan motors or operate them at reduced speed to maintain the unit operation, depending on the model.

Hinged Access Panels

Allows access to unit's major components with specifically designed hinged access panels. Panels are: filters, control box, fan motor and compressor.

Winter Start Kit

The winter start kit by ICP extends the low ambient limit of your rooftop to 25°F (-4°C). The kit bypasses the low pressure switch, preventing nuisance tripping of the low pressure switch. Other low ambient precautions may still be prudent.

Alternate Motors and Drives

Some applications need larger horsepower motors, some need more airflow, and some need both. Regardless of the case, your ICP expert has a factory installed combination to meet your application. A wide selection of motors and pulleys (drives) are available, factory installed, to handle nearly any application.

Thru-the-Base Connections

Thru-the-base connections, available as either an accessory or as a factory option, are necessary to ensure proper connection and seal when routing wire and piping through the rooftop's basepan and curb. These couplings eliminate roof penetration and should be considered for gas lines, main power lines, as well as control power.

Electric Heaters

ICP offers a full-line of field-installed accessory heaters. The heaters are very easy to use, install and are all pre-engineered and certified.

Table 2 – AHRI COOLING RATING TABLES

Unit	Cooling Stages	Nom. Capacity (tons)	Net Cooling Capacity (MBH)	Total Power (KW)	SEER	EER
RAX036	1	3	35.4	3.0	14.0	12.00
RAX048	1	4	47.5	4.0	14.0	12.00
RAX040	1	5	58.5	4.9	14.1	12.00

LEGEND

- AHRI – Air Conditioning, Heating and Refrigeration Institute
- ASHRAE – American Society of Heating, Refrigerating and Air Conditioning, Inc.
- EER – Energy Efficiency Ratio
- SEER – Seasonal Energy Efficiency Ratio

NOTES

1. Rated and certified under AHRI Standard 210/240.
2. Ratings are based on:
Cooling Standard: 80°F (27°C) db, 67°F (19°C) wb indoor air temp and 95°F db outdoor air temp.
3. All RAX units comply with ASHRAE 90.1 and Department of Energy (DOE) Energy Standard for minimum SEER and EER requirements.
4. RAX units comply with US Energy Policy Act (2005). To evaluate code compliance requirements, refer to state and local codes.



Use of the AHRI Certified TM Mark indicates a manufacturer's participation in the program. For verification of certification for individual products, go to www.ahridirectory.org.



Table 3 – MINIMUM – MAXIMUM AIRFLOWS COOLING AND ELECTRIC HEAT

Unit	Cooling		Electric Heaters	
	Minimum	Maximum	Minimum	Maximum
RAX036	900	1500	900	1500
RAX048	1200	2000	1200	2000
RAX060	1500	2500	1500	2500

Table 4 – SOUND PERFORMANCE TABLE

Unit	Cooling Stages	Outdoor Sound (dB) @60hz								
		A-Weighted	63	125	250	500	1000	2000	4000	8000
RAX036	1	76	78.2	78.0	74.2	73.3	70.6	66.0	62.4	56.9
RAX048	1	81	90.9	84.6	79.5	77.9	76.5	71.1	66.9	62.5
RAX060	1	77	87.5	82.5	76.1	73.6	71.3	67.1	64.1	60.0

LEGEND

dB – Decibel

NOTES:

1. Outdoor sound data is measure in accordance with AHRI standard 270.
2. Measurements are expressed in terms of sound power. Do not compare these values to sound pressure values because sound pressure accounts for specific environmental factors which do not match individual applications. Sound power values are independent of the environment and therefore more accurate.
3. A-weighted sound ratings filter out very high and very low frequencies, to better approximate the response of an "average" human ear. A-weighted measurements for ICP units are taken in accordance with 270.



Table 5 – PHYSICAL DATA

(COOLING)

3 – 6 TONS

		RAX036	RAX048	RAX060	
Refrigeration System	# Circuits / # Comp. / Type	1 / 1 / Scroll	1 / 1 / Scroll	1 / 1 / Scroll	
	R-410A refig. 1 phase (lbs-oz)	7-2	10-8	16-0	
	R-410A refig. 3 phase (lbs-oz)	7-2	10-8	14-8	
	Hot Gas ReHeat R-410A refig. charge (lbs - oz)	10-6	15-5	26-0	
	Metering Device (A)	Acutrol	Acutrol	Acutrol	
	Hot Gas ReHeat Metering Device (B)	Acutrol + TXV	Acutrol + TXV	Acutrol + TXV	
	High-press. Trip / Reset (psig)	630 / 505	630 / 505	630 / 505	
Low-press. Trip / Reset (psig)	54 / 117	54 / 117	54 / 117		
Compressor Capacity Staging (%)	100%	100%	100%		
Evap. Coil	Material (Tube/Fin)	Cu / Al	Cu / Al	Cu / Al	
	Coil type	3/8-in RTPF	3/8-in RTPF	3/8-in RTPF	
	Rows / FPI	3 / 15	3 / 15	4 / 15	
	Total Face Area (ft ²)	5.5	5.5	7.3	
	Condensate Drain Conn. Size	3/4-in	3/4-in	3/4-in	
Hot Gas ReHeat Coil	Material (Tube/Fin)	Cu / Al	Cu / Al	Cu / Al	
	Coil type	3/8-in RTPF	3/8-in RTPF	3/8-in RTPF	
	Rows / FPI	1 / 17	2 / 17	2 / 17	
	Total Face Area (ft ²)	3.9	3.9	5.2	
Evap. Fan and Motor	Standard Static 1 phase	Motor Qty / Drive Type	1 / Direct	1 / Direct	1 / Direct
		Max BHP	1	1	1
		RPM Range	600-1200	600-1200	600-1200
		Motor Frame Size	48	48	48
		Fan Qty / Type	1 / Centrifugal	1 / Centrifugal	1 / Centrifugal
		Fan Diameter (in)	10 x 10	10 x 10	10 x 10
	Medium Static 1 phase	Motor Qty / Drive Type	1 / Belt	1 / Belt	1 / Belt
		Max BHP	1.2	1.2	1.5
		RPM Range	770-1175	770-1175	1035-1466
		Motor Frame Size	48	48	56
		Fan Qty / Type	1 / Centrifugal	1 / Centrifugal	1 / Centrifugal
		Fan Diameter (in)	10 x 10	10 x 10	10 x 10
	High Static 1 phase	Motor Qty / Drive Type	1 / Belt	1 / Belt	N/A
		Max BHP	1.5	1.5	N/A
		RPM Range	1035-1466	1035-1466	N/A
		Motor Frame Size	56	56	N/A
		Fan Qty / Type	1 / Centrifugal	1 / Centrifugal	N/A
		Fan Diameter (in)	10 x 10	10 x 10	N/A
	Standard Static 3 phase	Motor Qty / Drive Type	1 / Direct	1 / Direct	1 / Direct
		Max BHP	1	1	1
		RPM Range	600-1200	600-1200	600-1200
		Motor Frame Size	48	48	48
		Fan Qty / Type	1 / Centrifugal	1 / Centrifugal	1 / Centrifugal
		Fan Diameter (in)	10 x 10	10 x 10	11 x 10
	Medium Static 3 phase	Motor Qty / Drive Type	1 / Belt	1 / Belt	1 / Belt
		Max BHP	1.7	1.7	2.9
RPM Range		770-1175	920-1303	1035-1466	
Motor Frame Size		48	56	56	
Fan Qty / Type		1 / Centrifugal	1 / Centrifugal	1 / Centrifugal	
Fan Diameter (in)		10 x 10	10 x 10	10 x 10	
High Static 3 phase	Motor Qty / Drive Type	1 / Belt	1 / Belt	1 / Belt	
	Max BHP	2.9	2.9	2.9	
	RPM Range	1035-1466	1208-1639	1303-1687	
	Motor Frame Size	56	56	56	
	Fan Qty / Type	1 / Centrifugal	1 / Centrifugal	1 / Centrifugal	
	Fan Diameter (in)	10 x 10	10 x 10	10 x 10	
Cond. Coil 1 phase	Material (Tube/Fin)	Cu / Al	Cu / Al	Cu / Al	
	Coil type	3/8-in RTPF	3/8-in RTPF	3/8-in RTPF	
	Rows / FPI	1 / 17	2 / 17	2 / 17	
	Total Face Area (ft ²)	16.5	16.5	21.3	
	3 phase	Material (Tube/Fin)	Cu / Al	Cu / Al	Cu / Al
		Coil type	3/8-in RTPF	3/8-in RTPF	3/8-in RTPF
Rows..Fins/in.		1 / 17	2 / 17	2 / 17	
Total Face Area (ft ²)	16.5	14.6	18.8		
Cond. fan / motor	Qty / Motor Drive Type	1 / Direct	1 / Direct	1 / Direct	
	Motor HP / RPM	1/8 / 825	1/4 / 1100	1/4 / 1100	
	Fan diameter (in)	22	22	22	
Filters	RA Filter # / Size (in)	2 / 16 x 25 x 2	2 / 16 x 25 x 2	4 / 16 x 25 x 2	
	OA inlet screen # / Size (in)	1 / 20 x 24 x 1	1 / 20 x 24 x 1	1 / 20 x 24 x 1	

N/A – Not Available

CURBS, WEIGHTS & DIMENSIONS

CONNECTION SIZES	
A	1 3/8" [35] DIA. FIELD POWER SUPPLY HOLE
B	2" [51] DIA. POWER SUPPLY KNOCKOUT
C	1 3/4" [44] DIA. GAUGE ACCESS PLUG
D	7/8" [22] DIA. FIELD CONTROL WIRING HOLE
E	3/4"-14 NPT CONDENSATE DRAIN
G	2 1/2" [64] DIA. POWER SUPPLY KNOCK-OUT

THRU-THE-BASE CHART FOR USE WITH RAX036-060		
W	1/2"	REQ'D HOLE SIZE (MAX.)
X	1/2"	ACC. [22.2]
Y	3/4" [001]	POWER [1 7/8" [28.4]
FOR "THRU-THE-BASE" FACTORY OPTION, FITTINGS FOR ONLY X & Y ARE PROVIDED		
SELECT EITHER 3/4" OR 1/2" FOR POWER, DEPENDING ON WIRE SIZE		

UNIT	J	K (1 PHASE)	K (3 PHASE)
RAX036	33-3/8 [847]	14-7/8 [377]	14-7/8 [377]
RAX048	33-3/8 [847]	14-7/8 [377]	18-5/8 [472]
RAX060	41-3/8 [1051]	14-7/8 [377]	18-5/8 [472]

- NOTES:
1. DIMENSIONS ARE IN INCHES. DIMENSIONS IN [] ARE IN MILLIMETERS.
 2. CENTER OF GRAVITY
 3. DIRECTION OF AIR FLOW

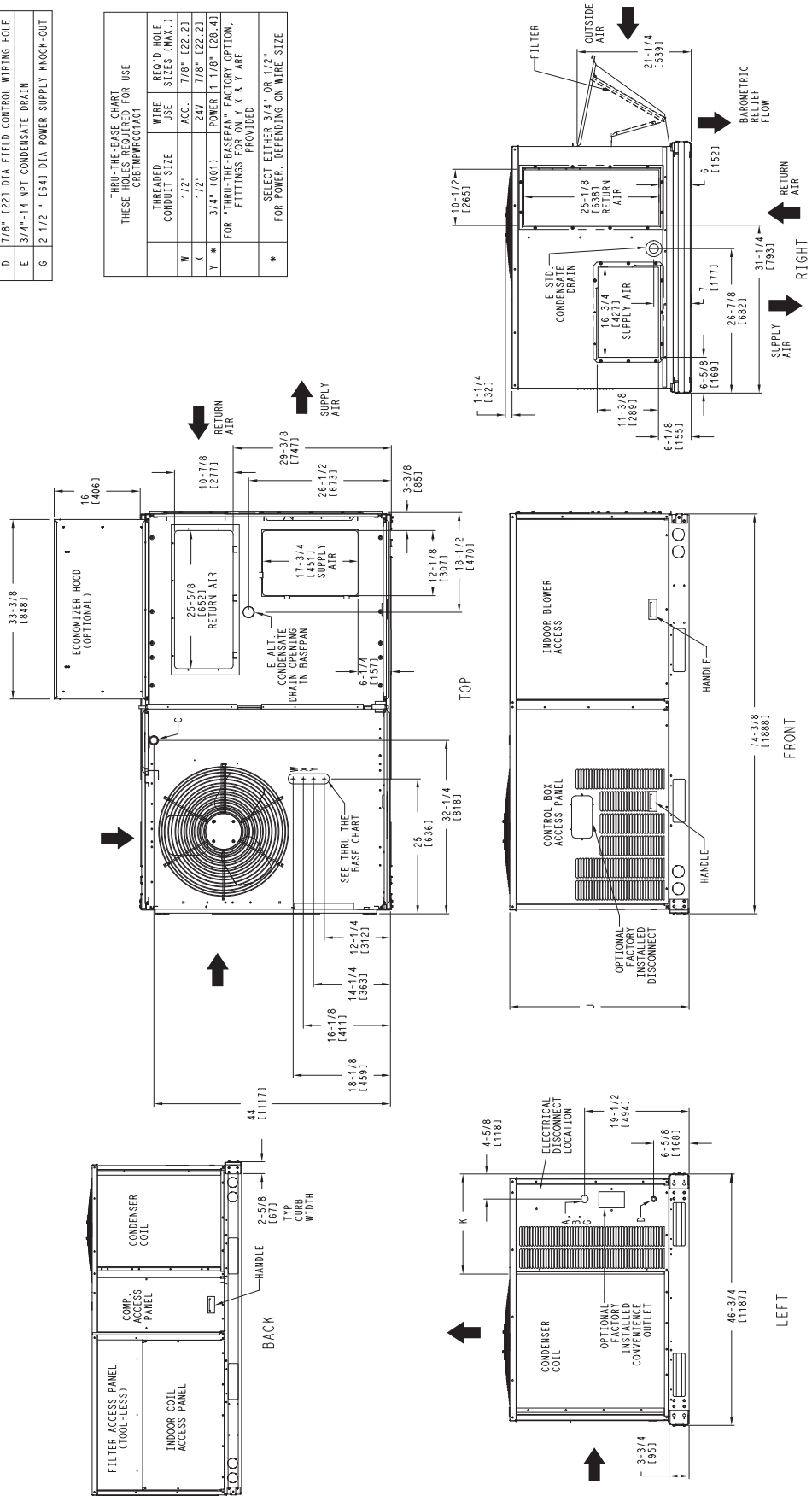

Fig. 1 - Dimensions RAX036-060

CURBS, WEIGHTS & DIMENSIONS (cont.)

UNIT	STD. UNIT WEIGHT		CORNER WEIGHT (A)		CORNER WEIGHT (B)		CORNER WEIGHT (C)		CORNER WEIGHT (D)		C.G.		HEIGHT			
	LBS.	KG.	LBS.	KG.	LBS.	KG.	LBS.	KG.	LBS.	KG.	X	Y	Z			
RAX036	445	201	127	57	104	47	97	44	118	53	33 1/2	[851]	22 1/2	[571]	19 3/4	[501]
RAX048	499	226	140	63	118	53	110	50	130	59	34 1/8	[866]	22 1/2	[571]	19 3/4	[501]
RAX060	552	250	143	65	149	67	133	60	127	57	38	[965]	22	[559]	20 3/4	[527]

* STANDARD UNIT WEIGHT IS WITHOUT ELECTRIC HEAT AND WITHOUT PACKAGING.
FOR OTHER OPTIONS AND ACCESSORIES, REFER TO THE PRODUCT DATA CATALOG.

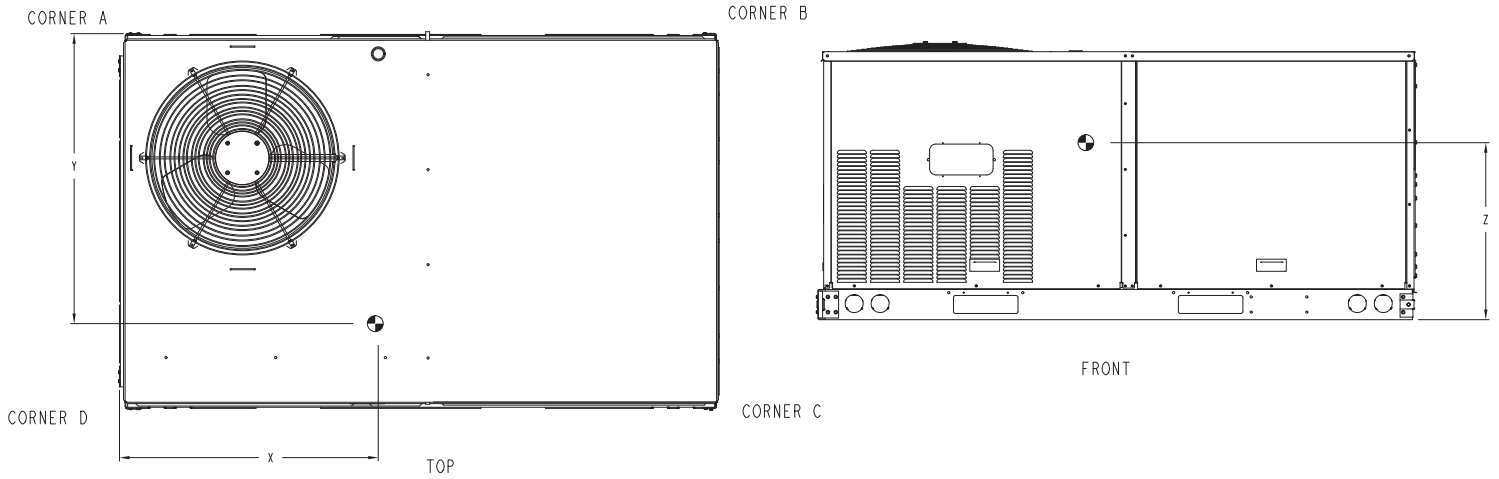
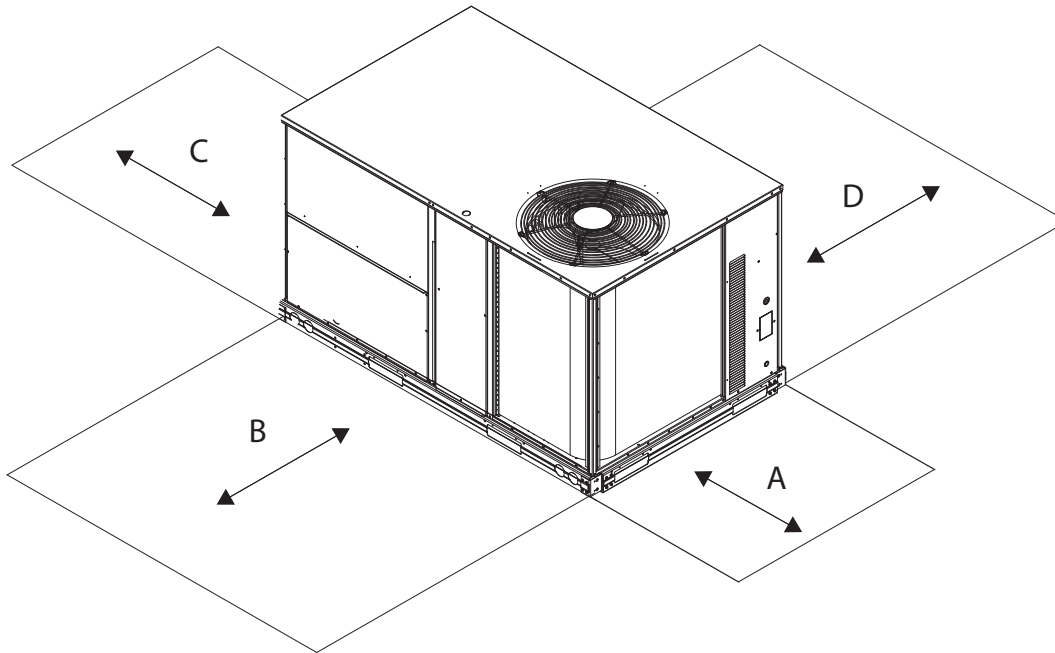

Fig. 2 – Dimensions RAX036-060



LOCATION	DIMENSION	CONDITION
A	48-in (1219 mm) 18-in (457 mm) 18-in (457 mm) 12-in (305 mm)	Unit disconnect is mounted on panel No disconnect, convenience outlet option Recommended service clearance Minimum clearance
B	42-in (1067 mm) 36-in (914 mm) Special	Surface behind servicer is grounded (e.g., metal, masonry wall) Surface behind servicer is electrically non-conductive (e.g., wood, fiberglass) Check sources of flue products within 10-ft of unit fresh air intake hood
C	36-in (914 mm) 18-in (457 mm)	Side condensate drain is used Minimum clearance
D	42-in (1067 mm) 36-in (914 mm) Special	Surface behind servicer is grounded (e.g., metal, masonry wall, another unit) Surface behind servicer is electrically non-conductive (e.g., wood, fiberglass) Check for adjacent units or building fresh air intakes within 10-ft (3 m) of this unit's flue outlet

C08337

NOTE:

Unit not designed to have overhead obstruction. Contact Application Engineering for guidance on any application planning overhead obstruction or for vertical clearances.

Fig. 3 – Service Clearance

CURBS, WEIGHTS & DIMENSIONS (cont.)

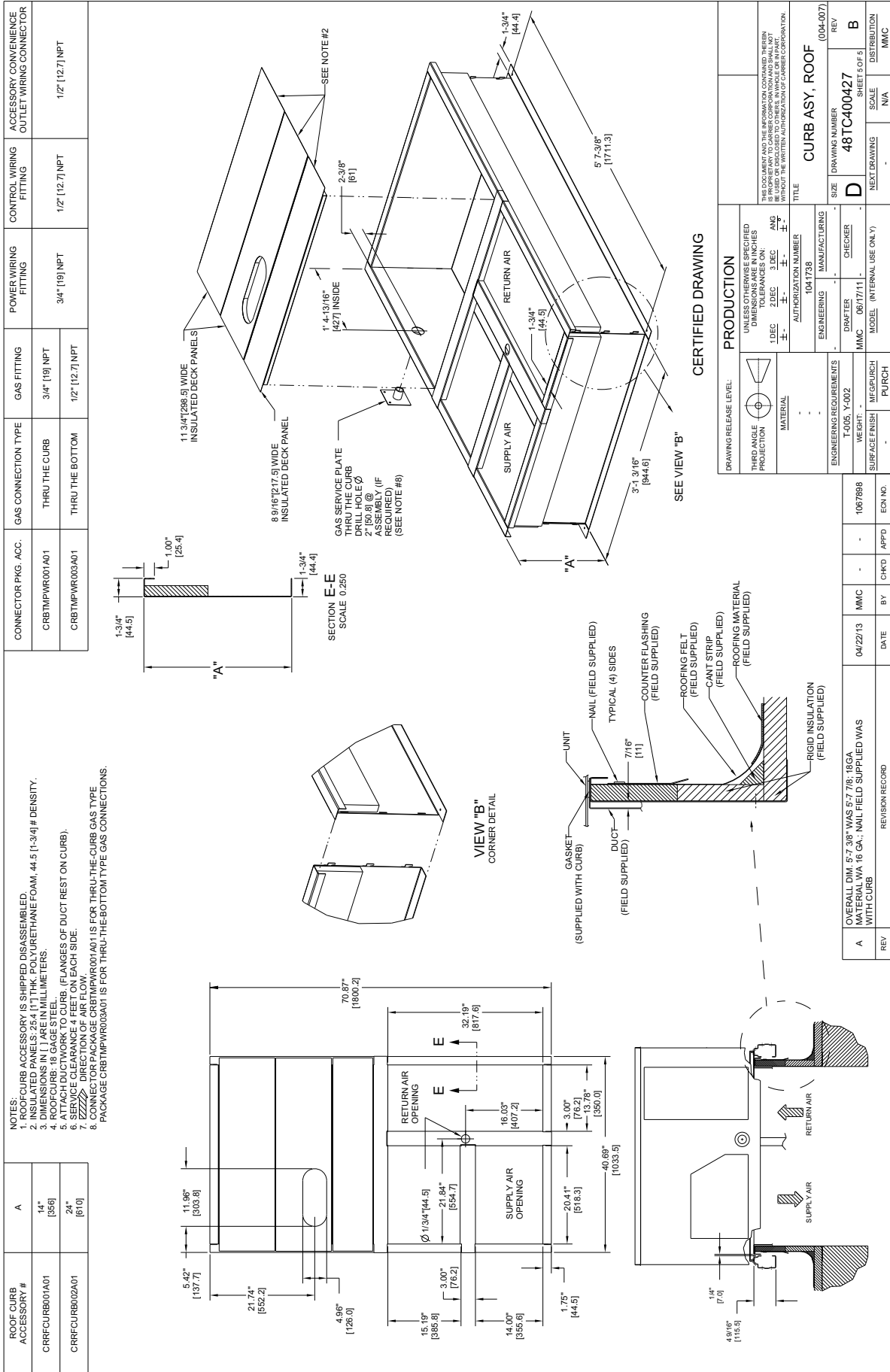

Fig. 4 – Roof Curb Details RAX036–060

Specifications subject to change without notice.

513 21 4100 01

OPTION / ACCESSORY WEIGHTS

Option / Accessory	OPTION / ACCESSORY WEIGHTS					
	04		05		06	
	lb	kg	lb	kg	lb	kg
Hot Gas ReHeat ¹	50	23	50	23	55	25
Power Exhaust – vertical	45	20	45	20	45	20
Power Exhaust – horizontal	30	14	30	14	30	14
EconoMi\$er (IV, X)	35	16	35	16	35	16
Two Position damper	39	18	39	18	39	18
Manual Dampers	12	5	12	5	12	5
Hail Guard (louvered)	13	6	13	6	17	8
Cu/Cu Condenser Coil ²	37	17	74	34	95	43
Cu/Cu Condenser and Evaporator Coils ²	75	34	112	51	165	75
Roof Curb (14-in. curb)	115	52	115	52	115	52
Roof Curb (24-in. curb)	197	89	197	89	197	89
CO ₂ sensor	2	1	2	1	2	1
Electric Heater	10	5	12	5	12	5
Single Point Kit	10	5	10	5	10	5
Optional Indoor Motor/Drive	6	3	6	3	17	8
Motor Master Controller	9	4	9	4	9	4
Supply Smoke Detector	7	3	7	3	7	3
Non-Fused Disconnect	5	2	5	2	5	2
Non-Powered Convenience outlet	4	2	4	2	4	2
Enthalpy Sensor	2	1	2	1	2	1
Differential Enthalpy Sensor	3	1	3	1	3	1

NOTE: Where multiple variations are available, the heaviest combination is listed.

– Not Available

¹ For Hot Gas ReHeat add MotorMaster Controller.

² Where available.

APPLICATION DATA

Min operating ambient temp (cooling):

In mechanical cooling mode, your ICP rooftop can safely operate down to an outdoor ambient temperature of 40°F (4°C) and 25°F (-4°C), with an accessory winter start kit. It is possible to provide cooling at lower outdoor ambient temperatures by using less outside air, economizers, and/or accessory low ambient kits.

Max operating ambient temp (cooling):

The maximum operating ambient temperature for cooling mode is 115°F (46°C). While cooling operation above 115°F (46°C) may be possible, it could cause either a reduction in performance, reliability, or a protective action by the unit's internal safety devices.

Min and max airflow (cooling mode):

To maintain safe and reliable operation of your rooftop, operate within the cooling airflow limits. Operating above the max may cause blow-off, undesired airflow noise, or airflow related problems with the rooftop unit. Operating below the min may cause problems with coil freeze-up.

Airflow:

All units are draw-through in cooling mode.

Outdoor air application strategies:

Economizers reduce operating expenses and compressor run time by providing a free source of cooling and a means of ventilation to match application changing needs. In fact, they should be considered for most applications. Also, consider the various economizer control methods and their benefits, as well as sensors required to accomplish your application goals. Please contact your local ICP representative for assistance.

Motor limits, Brake horsepower (BHP):

Due to ICP's internal unit design, air path, and specially designed motors, the full horsepower (maximum continuous BHP) band, as listed in the Physical Data table, can be used with the utmost confidence. There is no need for extra safety factors, as ICP's motors are designed and rigorously tested to use the entire, listed BHP range without either nuisance tripping or premature motor failure.

Sizing a rooftop

Bigger isn't necessarily better. While an air conditioner needs to have enough capacity to meet the load, it doesn't need excess capacity. In fact, having excess capacity typically results in very poor part load performance and humidity control.

Using higher design temperatures than ASHRAE recommends for your location, adding "safety factors" to the calculated load, and rounding up to the next largest unit, are all signs of oversizing air conditioners. Oversizing can cause short-cycling, and short cycling leads to poor humidity control, reduced efficiency, higher utility bills, drastic indoor temperature swings, excessive noise, and increased wear and tear on the air conditioner.

Rather than oversizing an air conditioner, wise contractors and engineers "right-size" or even slightly undersize air conditioners. Correctly sizing an air conditioner controls humidity better; promotes efficiency; reduces utility bills; extends equipment life, and maintains even, comfortable temperatures. Please contact your local ICP representative for assistance.

Low ambient applications

When equipped with a ICP economizer, your rooftop unit can cool your space by bringing in fresh, cool outside air. In fact, when so equipped, accessory low ambient kit may not be necessary. In low ambient conditions, unless the outdoor air is excessively humid or contaminated, economizer-based "free cooling" is the preferred less costly and energy conscious method.

In low ambient applications where outside air might not be desired (such as contaminated or excessively humid outdoor environments), your ICP rooftop can operate at ambient temperatures down to -20°F (-29°C) using the recommended accessory Motormaster low ambient controller.

Winter start

ICP's winter start kit extends the low ambient limit of your rooftop to 25°F (-4°C). The kit bypasses the low pressure switch, preventing nuisance tripping of the low pressure switch. Other low ambient precautions may still be prudent.

Table 6 – COOLING CAPACITIES

1-STAGE COOLING

3 TONS

RAX036				Ambient Temperature											
				85			95			105			115		
				EA (dB)			EA (dB)			EA (dB)			EA (dB)		
				75	80	85	75	80	85	75	80	85	75	80	85
900 Cfm	EAT (wb)	58	TC	28.7	28.7	32.6	25.1	25.1	28.6	22.2	22.2	25.3	19.5	19.5	22.2
			SHC	24.8	28.7	32.6	21.7	25.1	28.6	19.1	22.2	25.3	16.7	19.5	22.2
		62	TC	31.8	31.8	32.4	26.0	26.0	29.5	22.3	22.3	26.4	19.5	19.5	23.2
			SHC	23.3	27.9	32.4	20.6	25.0	29.5	18.1	22.3	26.4	15.8	19.5	23.2
		67	TC	36.5	36.5	36.5	34.2	34.2	34.2	29.2	29.2	29.2	23.7	23.7	23.7
			SHC	19.4	24.0	28.5	18.4	22.9	27.4	16.2	20.8	25.3	14.1	18.6	23.1
		72	TC	40.3	40.3	40.3	38.2	38.2	38.2	35.6	35.6	35.6	32.4	32.4	32.4
			SHC	14.9	19.5	24.1	13.9	18.5	23.1	12.9	17.4	22.0	11.6	16.2	20.7
		76	TC	-	43.1	43.1	-	41.0	41.0	-	38.6	38.6	-	35.9	35.9
			SHC	-	15.7	20.6	-	14.8	19.8	-	13.9	18.8	-	12.8	17.6
1050 Cfm	EAT (wb)	58	TC	31.8	31.8	36.2	28.3	28.3	32.1	24.9	24.9	28.4	21.9	21.9	24.9
			SHC	27.5	31.8	36.2	24.4	28.3	32.1	21.5	24.9	28.4	18.8	21.9	24.9
		62	TC	33.8	33.8	36.1	28.9	28.9	33.4	25.0	25.0	29.6	21.9	21.9	26.0
			SHC	25.7	30.9	36.1	23.2	28.3	33.4	20.4	25.0	29.6	17.8	21.9	26.0
		67	TC	37.8	37.8	37.8	35.5	35.5	35.5	31.7	31.7	31.7	25.8	25.8	26.2
			SHC	20.7	25.9	31.1	19.7	24.9	30.1	18.1	23.3	28.6	15.8	21.0	26.2
		72	TC	41.5	41.5	41.5	39.3	39.3	39.3	36.8	36.8	36.8	33.6	33.6	33.6
			SHC	15.4	20.6	25.8	14.5	19.7	24.9	13.5	18.7	23.9	12.2	17.5	22.7
		76	TC	-	44.2	44.2	-	42.0	42.0	-	39.6	39.6	-	36.9	36.9
			SHC	-	16.4	22.1	-	15.5	21.1	-	14.5	20.0	-	13.5	18.9
1200 Cfm	EAT (wb)	58	TC	34.1	34.1	38.8	31.3	31.3	35.6	27.5	27.5	31.2	24.1	24.1	27.4
			SHC	29.5	34.1	38.8	27.0	31.3	35.6	23.7	27.5	31.2	20.7	24.1	27.4
		62	TC	34.9	34.9	39.1	32.9	32.9	35.5	27.5	27.5	32.6	24.1	24.1	28.6
			SHC	27.5	33.3	39.1	25.2	30.3	35.5	22.5	27.5	32.6	19.6	24.1	28.6
		67	TC	38.8	38.8	38.8	36.4	36.4	36.4	33.3	33.3	33.3	27.7	27.7	29.2
			SHC	21.9	27.7	33.5	20.9	26.7	32.6	19.6	25.5	31.4	17.4	23.3	29.2
		72	TC	42.4	42.4	42.4	40.1	40.1	40.1	37.7	37.7	37.7	34.5	34.5	34.5
			SHC	15.8	21.6	27.4	14.9	20.7	26.5	13.9	19.8	25.6	12.7	18.7	24.6
		76	TC	-	44.9	44.9	-	42.7	42.7	-	40.3	40.3	-	37.7	37.7
			SHC	-	16.8	23.1	-	15.9	22.1	-	15.0	21.1	-	14.0	20.1
1350 Cfm	EAT (wb)	58	TC	35.6	35.6	40.4	33.6	33.6	38.1	29.8	29.8	33.9	26.2	26.2	29.8
			SHC	30.8	35.6	40.4	29.0	33.6	38.1	25.7	29.8	33.9	22.5	26.2	29.8
		62	TC	36.3	36.3	39.9	33.7	33.7	39.7	29.9	29.9	35.3	26.2	26.2	31.0
			SHC	28.2	34.1	39.9	27.6	33.7	39.7	24.4	29.9	35.3	21.4	26.2	31.0
		67	TC	39.5	39.5	39.5	37.2	37.2	37.2	34.0	34.0	34.0	29.3	29.3	32.0
			SHC	22.9	29.4	35.8	22.0	28.5	34.9	20.8	27.3	33.9	18.9	25.4	32.0
		72	TC	43.0	43.0	43.0	40.7	40.7	40.7	38.3	38.3	38.3	35.2	35.2	35.2
			SHC	16.2	22.5	28.9	15.3	21.7	28.1	14.3	20.8	27.2	13.2	19.7	26.3
		76	TC	-	45.5	45.5	-	43.3	43.3	-	40.8	40.8	-	38.1	38.1
			SHC	-	17.3	24.0	-	16.4	23.1	-	15.4	22.1	-	14.5	21.1
1500 Cfm	EAT (wb)	58	TC	36.8	36.8	41.8	34.8	34.8	39.5	32.0	32.0	36.4	28.1	28.1	31.9
			SHC	31.9	36.8	41.8	30.1	34.8	39.5	27.7	32.0	36.4	24.2	28.1	31.9
		62	TC	36.9	36.9	43.5	35.4	35.4	38.8	32.1	32.1	37.9	28.1	28.1	33.3
			SHC	30.2	36.9	43.5	27.4	33.1	38.8	26.2	32.1	37.9	22.9	28.1	33.3
		67	TC	40.1	40.1	40.1	37.7	37.7	37.7	34.7	34.7	36.2	30.7	30.7	34.6
			SHC	23.9	31.0	38.0	23.0	30.1	37.2	21.9	29.0	36.2	20.3	27.5	34.6
		72	TC	43.6	43.6	43.6	41.3	41.3	41.3	38.7	38.7	38.7	35.7	35.7	35.7
			SHC	16.5	23.4	30.2	15.6	22.5	29.5	14.7	21.7	28.6	13.6	20.8	27.9
		76	TC	-	46.0	46.0	-	43.7	43.7	-	41.2	41.2	-	38.5	38.5
			SHC	-	17.6	24.8	-	16.7	23.9	-	15.8	22.9	-	14.8	22.0

LEGEND:

- Do not operate
- Cfm - Cubic feet per minute (supply air)
- EAT(db) - Entering air temperature (dry bulb)
- EAT(wb) - Entering air temperature (wet bulb)
- SHC - Sensible heat capacity
- TC - Total capacity

Table 7 – COOLING CAPACITIES

1-STAGE COOLING

3 TONS

RAX036 (3 TONS) – UNIT WITH HOT GAS REHEAT SYSTEM IN SUBCOOLING MODE										
TEMP (F) AIR ENT CONDENSER (Edb)		AIR ENTERING EVAPORATOR – SCFM								
		900			1200			1500		
		Air Entering Evaporator – Ewb (F)								
		72	67	62	72	67	62	72	67	62
75	TC	30.9	32.0	31.9	30.7	33.5	34.3	34.8	31.8	27.6
	SHC	15.1	20.0	26.3	25.1	20.4	15.4	14.0	18.2	21.9
	kW	2.51	2.49	2.42	2.82	2.74	2.68	3.09	3.01	2.88
85	TC	32.8	28.4	23.4	18.7	23.8	29.3	24.5	18.8	13.6
	SHC	11.0	14.6	17.9	13.4	10.3	7.1	2.6	5.6	8.6
	kW	3.36	3.23	3.06	3.62	3.41	3.24	3.79	3.58	3.39
95	TC	31.3	32.0	31.9	30.7	33.5	34.3	34.8	31.8	27.6
	SHC	15.3	20.0	26.3	25.1	20.4	15.4	14.0	18.2	21.9
	kW	2.53	2.49	2.41	2.82	2.74	2.68	3.09	3.01	2.88
105	TC	32.8	28.4	23.4	18.7	23.8	29.3	24.5	18.8	13.6
	SHC	11.0	14.6	17.9	13.4	10.3	7.1	2.6	5.6	8.6
	kW	3.36	3.23	3.06	3.62	3.41	3.24	3.79	3.58	3.39
115	TC	31.3	32.0	31.9	30.7	33.5	34.3	34.8	31.8	27.6
	SHC	15.3	20.0	26.3	25.1	20.4	15.4	14.0	18.2	21.9
	kW	2.53	2.49	2.41	2.82	2.74	2.68	3.09	3.01	2.88

RAX036 (3 TONS) – UNIT WITH HOT GAS REHEAT SYSTEM IN HOT GAS REHEAT MODE										
TEMP (F) AIR ENT CONDENSER (Edb)		AIR ENTERING EVAPORATOR – Ewb (F)								
		75 Dry Bulb 62.5 Wet Bulb (50% Relative)			75 Dry Bulb 64 Wet Bulb (56% Relative)			75 Dry Bulb 65.3 Wet Bulb (60% Relative)		
		Air Entering Evaporator – Cfm								
		900	1200	1500	900	1200	1500	900	1200	1500
80	TC	12.26	13.13	13.65	13.53	14.48	15.00	14.73	15.63	16.20
	SHC	1.76	3.87	6.09	0.75	2.48	4.33	-0.06	1.30	2.81
	kW	1.92	1.93	1.94	1.96	1.98	2.00	2.00	2.01	2.02
75	TC	14.64	15.64	16.30	15.84	16.73	17.32	16.80	17.38	17.91
	SHC	3.87	6.09	8.38	2.88	4.59	6.29	2.03	3.14	4.39
	kW	1.87	1.88	1.88	1.89	1.90	1.91	1.91	1.92	1.93
70	TC	16.72	17.62	18.01	17.42	18.17	18.62	18.02	18.69	18.87
	SHC	5.89	7.85	9.40	4.65	6.08	7.35	3.71	5.09	5.59
	kW	1.78	1.80	1.82	1.81	1.83	1.84	1.82	1.82	1.86
60	TC	17.43	18.50	18.28	18.09	19.03	19.41	18.32	18.29	19.33
	SHC	7.75	10.06	9.51	7.08	8.34	9.60	6.29	6.94	7.88
	kW	1.66	1.62	1.70	1.67	1.69	1.68	1.69	1.70	1.71
50	TC	17.82	18.59	19.72	18.31	19.73	20.26	18.76	20.21	20.73
	SHC	6.40	7.99	10.05	4.79	6.71	7.97	3.40	5.11	6.16
	kW	1.98	2.03	1.94	2.01	1.94	1.97	2.03	1.96	1.99
40	TC	17.70	19.38	19.85	19.10	20.30	20.34	19.53	20.76	21.26
	SHC	6.30	8.74	10.17	5.54	7.26	8.05	4.13	5.64	6.67
	kW	2.07	1.95	1.99	1.93	1.91	2.02	1.96	1.94	1.97

LEGEND

- Edb – Entering Dry-Bulb
- Ewb – Entering Wet-Bulb
- kW – Compressor Motor Power Input
- ldb – Leaving Dry-Bulb
- lwb – Leaving Wet-Bulb
- SHC – Sensible Heat Capacity (1000 Btuh) Gross
- TC – Total Capacity (1000 Btuh) Gross

NOTES:

1. Direct interpolation is permissible. Do not extrapolate.
2. The following formulas may be used:

$$t_{ldb} = t_{edb} - \frac{\text{sensible capacity (Btuh)}}{1.10 \times \text{cfm}}$$

$$t_{lwb} = \text{Wet-bulb temperature corresponding to enthalpy of air leaving evaporator coil (} h_{lwb} \text{)}$$

$$h_{lwb} = h_{ewb} - \frac{\text{total capacity (Btuh)}}{4.5 \times \text{cfm}}$$
 Where: h_{ewb} = Enthalpy of air entering evaporator coil

Table 8 – COOLING CAPACITIES

1-STAGE COOLING

4 TONS

RAX048				Ambient Temperature											
				85			95			105			115		
				EA (dB)			EA (dB)			EA (dB)			EA (dB)		
				75	80	85	75	80	85	75	80	85	75	80	85
1200 Cfm	EAT (wb)	58	TC	41.5	41.5	47.0	38.9	38.9	44.0	36.2	36.2	41.0	33.4	33.4	37.8
			SHC	36.1	41.5	47.0	33.8	38.9	44.0	31.4	36.2	41.0	28.9	33.4	37.8
		62	TC	44.9	44.9	44.9	41.4	41.4	42.6	37.8	37.8	40.8	34.0	34.0	38.8
			SHC	32.6	38.5	44.3	30.9	36.8	42.6	29.2	35.0	40.8	27.3	33.1	38.8
		67	TC	49.7	49.7	49.7	46.8	46.8	46.8	43.1	43.1	43.1	39.2	39.2	39.2
			SHC	26.5	32.4	38.2	25.3	31.1	37.0	23.7	29.6	35.5	22.1	27.9	33.8
		72	TC	53.4	53.4	53.4	51.3	51.3	51.3	48.5	48.5	48.5	44.7	44.7	44.7
			SHC	19.8	25.7	31.6	19.0	24.8	30.7	17.8	23.7	29.6	16.4	22.3	28.1
		76	TC	-	55.3	55.3	-	53.3	53.3	-	51.6	51.6	-	48.6	48.6
			SHC	-	20.1	26.7	-	19.4	26.0	-	18.7	25.3	-	17.5	23.8
1400 Cfm	EAT (wb)	58	TC	44.4	44.4	50.2	41.6	41.6	47.0	38.7	38.7	43.8	35.7	35.7	40.5
			SHC	38.6	44.4	50.2	36.1	41.6	47.0	33.6	38.7	43.8	31.0	35.7	40.5
		62	TC	46.6	46.6	48.6	43.1	43.1	46.9	39.4	39.4	44.9	35.8	35.8	42.1
			SHC	35.2	41.9	48.6	33.5	40.2	46.9	31.7	38.3	44.9	29.4	35.8	42.1
		67	TC	51.2	51.2	51.2	48.5	48.5	48.5	44.7	44.7	44.7	40.7	40.7	40.7
			SHC	28.0	34.6	41.2	26.9	33.6	40.3	25.4	32.2	38.9	23.8	30.6	37.3
		72	TC	54.4	54.4	54.4	52.3	52.3	52.3	49.9	49.9	49.9	46.2	46.2	46.2
			SHC	20.2	26.7	33.2	19.4	25.9	32.5	18.5	25.2	31.9	17.1	23.8	30.6
		76	TC	-	55.9	55.9	-	53.9	53.9	-	52.1	52.1	-	49.7	49.7
			SHC	-	20.8	28.5	-	20.0	27.6	-	19.2	26.5	-	18.1	25.3
1600 Cfm	EAT (wb)	58	TC	46.6	46.6	52.7	43.8	43.8	49.6	40.8	40.8	46.2	37.7	37.7	42.7
			SHC	40.5	46.6	52.7	38.1	43.8	49.6	35.4	40.8	46.2	32.7	37.7	42.7
		62	TC	47.9	47.9	52.3	44.6	44.6	50.7	40.9	40.9	48.1	37.8	37.8	44.4
			SHC	37.5	44.9	52.3	35.9	43.3	50.7	33.7	40.9	48.1	31.1	37.8	44.4
		67	TC	51.5	51.5	51.5	48.7	48.7	48.7	44.9	44.9	44.9	40.7	40.7	42.0
			SHC	30.9	38.3	45.7	30.0	37.5	45.0	28.5	36.1	43.7	26.9	34.5	42.0
		72	TC	55.0	55.0	55.0	52.9	52.9	52.9	50.9	50.9	50.9	47.3	47.3	47.3
			SHC	20.4	27.5	34.6	19.6	26.8	33.9	18.9	26.3	33.8	17.6	25.2	32.7
		76	TC	-	56.3	56.3	-	54.3	54.3	-	52.3	52.3	-	50.3	50.3
			SHC	-	21.1	29.4	-	20.2	28.3	-	19.4	27.3	-	18.6	26.5
1800 Cfm	EAT (wb)	58	TC	48.4	48.4	54.7	45.7	45.7	51.7	42.7	42.7	48.3	39.4	39.4	44.6
			SHC	42.1	48.4	54.7	39.7	45.7	51.7	37.0	42.7	48.3	34.2	39.4	44.6
		62	TC	49.1	49.1	55.6	45.9	45.9	53.7	42.7	42.7	50.2	39.5	39.5	46.4
			SHC	39.5	47.6	55.6	37.8	45.8	53.7	35.2	42.7	50.2	32.5	39.5	46.4
		67	TC	53.0	53.0	53.0	50.6	50.6	50.6	47.0	47.0	47.0	42.7	42.7	43.7
			SHC	30.2	38.2	46.1	29.5	37.7	45.8	28.5	36.8	45.2	26.9	35.3	43.7
		72	TC	55.5	55.5	55.5	53.4	53.4	53.4	51.5	51.5	51.5	48.1	48.1	48.1
			SHC	20.6	28.2	35.7	19.8	27.5	35.2	19.2	27.3	35.4	18.1	26.4	34.6
		76	TC	-	56.6	56.6	-	54.6	54.6	-	52.5	52.5	-	50.8	50.8
			SHC	-	21.2	29.9	-	20.4	28.9	-	19.6	28.0	-	18.9	27.4
2000 Cfm	EAT (wb)	58	TC	49.9	49.9	56.4	47.4	47.4	53.6	44.3	44.3	50.1	40.9	40.9	46.3
			SHC	43.4	49.9	56.4	41.2	47.4	53.6	38.4	44.3	50.1	35.5	40.9	46.3
		62	TC	50.1	50.1	58.3	47.5	47.5	55.7	44.3	44.3	52.1	41.0	41.0	48.2
			SHC	41.1	49.7	58.3	39.2	47.5	55.7	36.5	44.3	52.1	33.8	41.0	48.2
		67	TC	53.5	53.5	53.5	51.3	51.3	51.3	47.8	47.8	48.1	43.5	43.5	46.6
			SHC	31.2	39.7	48.3	30.6	39.4	48.1	29.9	39.0	48.1	28.3	37.5	46.6
		72	TC	55.8	55.8	55.8	53.7	53.7	53.7	51.9	51.9	51.9	48.8	48.8	48.8
			SHC	20.7	28.7	36.7	19.9	28.1	36.2	19.4	28.0	36.7	18.5	27.4	36.4
		76	TC	-	56.9	56.9	-	54.8	54.8	-	52.7	52.7	-	51.1	51.1
			SHC	-	21.3	30.4	-	20.5	29.4	-	19.7	28.6	-	19.1	28.2

LEGEND:

- Do not operate
- Cfm - Cubic feet per minute (supply air)
- EAT(db) - Entering air temperature (dry bulb)
- EAT(wb) - Entering air temperature (wet bulb)
- SHC - Sensible heat capacity
- TC - Total capacity

Table 9 – COOLING CAPACITIES

1-STAGE COOLING

4 TONS

RAX048 (4 TONS) – UNIT WITH HOT GAS REHEAT SYSTEM IN SUBCOOLING MODE										
TEMP (F) AIR ENT CONDENSER (Edb)		AIR ENTERING EVAPORATOR – SCFM								
		1200			1600			2000		
		Air Entering Evaporator – Ewb (F)								
		72	67	62	72	67	62	72	67	62
75	TC	35.4	37.1	41.2	40.7	43.2	41.0	44.3	42.2	35.7
	SHC	16.4	21.6	31.5	31.3	24.3	16.9	16.0	22.4	26.9
	kW	3.06	3.07	3.06	3.44	3.43	3.41	3.84	3.82	3.72
85	TC	43.4	36.8	29.6	22.8	30.1	37.9	31.0	23.1	15.6
	SHC	13.0	17.6	21.5	15.5	11.7	7.8	2.0	5.7	9.2
	kW	4.28	4.20	4.05	4.77	4.57	4.42	5.17	4.99	4.81
95	TC	34.5	34.9	35.6	42.8	40.4	37.8	42.4	43.8	39.3
	SHC	16.3	20.9	27.7	36.7	23.8	16.2	16.4	26.1	34.3
	kW	3.25	3.25	3.24	3.63	3.63	3.61	4.04	4.02	4.00
105	TC	44.0	40.3	33.3	26.2	33.7	41.0	34.2	26.1	18.6
	SHC	15.1	22.9	28.9	22.6	17.2	11.1	5.0	10.6	15.8
	kW	4.49	4.47	4.32	4.99	4.87	4.69	5.50	5.28	5.09
115	TC	33.2	33.5	38.3	39.8	37.3	35.4	40.3	42.0	41.3
	SHC	15.6	20.3	31.2	34.7	22.3	15.3	15.9	26.2	39.6
	kW	3.53	3.51	3.46	3.89	3.89	3.88	4.31	4.30	4.26

RAX048 (4 TONS) – UNIT WITH HOT GAS REHEAT SYSTEM IN HOT GAS REHEAT MODE										
TEMP (F) AIR ENT CONDENSER (Edb)		AIR ENTERING EVAPORATOR – Ewb (F)								
		75 Dry Bulb 62.5 Wet Bulb (50% Relative)			75 Dry Bulb 64 Wet Bulb (56% Relative)			75 Dry Bulb 65.3 Wet Bulb (60% Relative)		
		Air Entering Evaporator – Cfm								
		1200	1600	2000	1200	1600	2000	1200	1600	2000
80	TC	15.33	16.26	16.40	17.32	18.21	18.24	18.97	19.72	19.66
	SHC	0.84	3.06	4.94	-0.09	1.62	2.93	-0.90	0.33	1.18
	kW	2.41	2.42	2.42	2.43	2.43	2.43	2.44	2.44	2.44
75	TC	19.17	20.36	20.57	20.97	21.94	21.95	22.30	23.03	22.88
	SHC	4.46	6.89	8.60	3.50	5.31	6.45	2.61	3.93	4.64
	kW	2.76	2.75	2.75	2.76	2.75	2.74	2.76	2.76	2.75
70	TC	22.63	23.67	23.55	23.97	24.55	24.19	24.87	25.09	24.52
	SHC	7.91	10.13	11.21	6.83	8.40	9.04	5.88	7.04	7.39
	kW	2.80	2.78	2.77	2.80	2.77	2.76	2.81	2.80	2.78
60	TC	27.32	28.34	21.46	27.68	16.17	25.05	28.38	18.51	20.56
	SHC	13.66	15.45	13.04	11.75	4.46	12.58	11.21	10.82	10.87
	kW	2.85	2.86	2.86	2.89	2.80	2.91	2.88	2.84	2.88
50	TC	11.00	11.31	12.76	14.48	13.83	13.72	15.32	15.18	17.14
	SHC	7.10	9.20	11.20	5.13	6.46	9.10	4.21	4.49	6.19
	kW	2.95	2.94	2.93	2.94	2.92	2.92	2.94	2.93	2.92
40	TC	9.73	9.83	9.75	12.40	12.60	12.20	15.23	15.45	15.13
	SHC	8.46	9.50	9.20	7.57	8.47	9.50	7.64	8.14	8.80
	kW	3.04	3.04	3.03	3.03	3.01	3.01	3.03	3.02	3.02

LEGEND

- Edb – Entering Dry-Bulb
- Ewb – Entering Wet-Bulb
- kW – Compressor Motor Power Input
- ldb – Leaving Dry-Bulb
- lwb – Leaving Wet-Bulb
- SHC – Sensible Heat Capacity (1000 Btuh) Gross
- TC – Total Capacity (1000 Btuh) Gross

NOTES:

1. Direct interpolation is permissible. Do not extrapolate.
2. The following formulas may be used:

$$t_{ldb} = t_{edb} - \frac{\text{sensible capacity (Btuh)}}{1.10 \times \text{cfm}}$$

$$t_{lwb} = \text{Wet-bulb temperature corresponding to enthalpy of air leaving evaporator coil } (h_{lwb})$$

$$h_{lwb} = h_{ewb} - \frac{\text{total capacity (Btuh)}}{4.5 \times \text{cfm}}$$
 Where: h_{ewb} = Enthalpy of air entering evaporator coil

Table 10 – COOLING CAPACITIES

1-STAGE COOLING

5 TONS

RAX060				Ambient Temperature											
				85			95			105			115		
				EA (dB)			EA (dB)			EA (dB)			EA (dB)		
				75	80	85	75	80	85	75	80	85	75	80	85
1500 Cfm	EAT (wb)	58	TC	53.0	53.0	60.2	50.0	50.0	56.8	46.9	46.9	53.4	44.4	44.4	50.4
			SHC	45.9	53.0	60.2	43.1	50.0	56.8	40.3	46.9	53.4	38.4	44.4	50.4
		62	TC	56.0	56.0	57.5	52.2	52.2	55.4	48.2	48.2	53.3	44.7	44.7	52.1
			SHC	41.4	49.5	57.5	39.3	47.4	55.4	37.2	45.2	53.3	36.2	44.2	52.1
		67	TC	62.4	62.4	62.4	58.8	58.8	58.8	54.8	54.8	54.8	51.0	51.0	51.0
			SHC	33.5	41.4	49.4	31.7	39.7	47.7	29.6	37.7	45.7	28.6	36.6	44.6
		72	TC	67.5	67.5	67.5	64.3	64.3	64.3	60.7	60.7	60.7	55.4	55.4	55.4
			SHC	25.0	32.4	39.8	23.3	31.0	38.6	21.5	29.3	37.0	19.8	27.2	34.7
		76	TC	-	71.1	71.1	-	68.3	68.3	-	64.8	64.8	-	58.4	58.4
			SHC	-	25.6	32.7	-	24.2	31.3	-	22.5	29.9	-	20.3	27.7
1750 Cfm	EAT (wb)	58	TC	56.7	56.7	64.3	53.5	53.5	60.8	50.2	50.2	57.2	47.4	47.4	53.9
			SHC	49.1	56.7	64.3	46.2	53.5	60.8	43.3	50.2	57.2	41.0	47.4	53.9
		62	TC	58.3	58.3	63.9	54.4	54.4	61.8	51.8	51.8	56.4	47.5	47.5	56.1
			SHC	45.3	54.6	63.9	43.2	52.5	61.8	39.6	48.0	56.4	38.9	47.5	56.1
		67	TC	64.0	64.0	64.0	60.6	60.6	60.6	56.6	56.6	56.6	52.3	52.3	52.3
			SHC	35.5	44.5	53.6	33.9	43.1	52.4	32.0	41.3	50.6	30.6	39.7	48.8
		72	TC	68.9	68.9	68.9	65.9	65.9	65.9	62.2	62.2	62.2	56.6	56.6	56.6
			SHC	25.5	33.9	42.2	24.0	32.7	41.4	22.2	31.1	40.1	20.2	28.7	37.1
		76	TC	-	72.4	72.4	-	69.7	69.7	-	66.1	66.1	-	59.5	59.5
			SHC	-	26.4	34.9	-	24.9	33.2	-	23.2	31.7	-	21.0	29.5
2000 Cfm	EAT (wb)	58	TC	59.8	59.8	67.8	56.5	56.5	64.2	53.1	53.1	60.4	50.0	50.0	56.8
			SHC	51.8	59.8	67.8	48.9	56.5	64.2	45.8	53.1	60.4	43.3	50.0	56.8
		62	TC	60.2	60.2	69.7	57.0	57.0	66.0	53.2	53.2	62.9	50.1	50.1	59.2
			SHC	48.8	59.3	69.7	46.1	56.0	66.0	43.4	53.2	62.9	41.1	50.1	59.2
		67	TC	65.3	65.3	65.3	61.8	61.8	61.8	56.7	56.7	57.6	52.4	52.4	55.7
			SHC	37.3	47.4	57.4	35.9	46.2	56.6	36.4	47.0	57.6	34.9	45.3	55.7
		72	TC	70.2	70.2	70.2	67.0	67.0	67.0	63.2	63.2	63.2	57.3	57.3	57.3
			SHC	26.1	35.4	44.8	24.5	34.1	43.7	22.8	32.7	42.6	20.6	30.1	39.5
		76	TC	-	73.4	73.4	-	70.6	70.6	-	67.1	67.1	-	60.3	60.3
			SHC	-	27.0	36.5	-	25.5	35.0	-	23.8	33.3	-	21.5	31.0
2250 Cfm	EAT (wb)	58	TC	62.2	62.2	70.5	59.0	59.0	66.9	55.5	55.5	63.0	52.1	52.1	59.1
			SHC	54.0	62.2	70.5	51.1	59.0	66.9	47.9	55.5	63.0	45.0	52.1	59.1
		62	TC	63.4	63.4	70.9	59.1	59.1	69.7	55.5	55.5	65.6	52.1	52.1	61.5
			SHC	50.2	60.5	70.9	48.5	59.1	69.7	45.4	55.5	65.6	42.7	52.1	61.5
		67	TC	66.3	66.3	66.3	62.4	62.4	62.4	58.9	58.9	59.6	54.1	54.1	56.3
			SHC	38.9	50.0	61.0	39.2	50.8	62.3	36.2	47.9	59.6	34.0	45.2	56.3
		72	TC	71.1	71.1	71.1	68.0	68.0	68.0	64.1	64.1	64.1	57.9	57.9	57.9
			SHC	26.5	36.8	47.1	25.0	35.5	46.1	23.3	34.1	45.0	21.0	31.3	41.7
		76	TC	-	74.0	74.0	-	71.4	71.4	-	67.8	67.8	-	61.0	61.0
			SHC	-	27.3	37.6	-	26.0	36.5	-	24.3	34.9	-	21.8	32.2
2500 Cfm	EAT (wb)	58	TC	64.0	64.0	72.4	60.9	60.9	69.1	57.4	57.4	65.2	53.3	53.3	60.5
			SHC	55.5	64.0	72.4	52.8	60.9	69.1	49.6	57.4	65.2	46.1	53.3	60.5
		62	TC	64.0	64.0	75.3	61.0	61.0	71.9	57.4	57.4	67.9	53.4	53.4	63.0
			SHC	52.7	64.0	75.3	50.1	61.0	71.9	47.0	57.4	67.9	43.8	53.4	63.0
		67	TC	67.3	67.3	67.3	63.7	63.7	64.5	59.5	59.5	64.2	54.6	54.6	59.3
			SHC	40.6	52.5	64.5	39.6	52.0	64.5	38.7	51.5	64.2	35.4	47.3	59.3
		72	TC	71.7	71.7	71.7	68.8	68.8	68.8	64.9	64.9	64.9	58.4	58.4	58.4
			SHC	26.7	37.9	49.1	25.4	37.0	48.5	23.7	35.5	47.3	21.2	32.4	43.6
		76	TC	-	74.5	74.5	-	72.1	72.1	-	68.4	68.4	-	61.6	61.6
			SHC	-	27.4	38.5	-	26.3	37.7	-	24.7	36.3	-	22.1	33.3

LEGEND:

- Do not operate
- Cfm - Cubic feet per minute (supply air)
- EAT(db) - Entering air temperature (dry bulb)
- EAT(wb) - Entering air temperature (wet bulb)
- SHC - Sensible heat capacity
- TC - Total capacity

Table 11 – COOLING CAPACITIES

1-STAGE COOLING

5 TONS

RAX060 (5 TONS) – UNIT WITH HOT GAS REHEAT SYSTEM IN SUBCOOLING MODE										
TEMP (F) AIR ENT CONDENSER (Edb)		AIR ENTERING EVAPORATOR – SCFM								
		1750			2000			2250		
		Air Entering Evaporator -- Ewb (F)								
		72	67	62	72	67	62	72	67	62
75	TC	51.1	56.4	57.9	47.8	49.9	57.3	49.6	48.9	53.8
	SHC	25.5	36.1	50.4	24.6	31.3	50.3	25.8	32.0	44.8
	kW	3.20	3.30	3.19	3.25	3.18	3.13	3.22	3.13	3.25
85	TC	54.1	60.4	61.0	56.4	60.4	60.5	56.7	60.7	58.2
	SHC	47.2	38.7	28.0	52.3	40.6	28.8	27.2	42.6	56.5
	kW	3.59	3.67	3.79	3.81	3.70	3.60	3.70	3.74	3.61
95	TC	62.4	56.6	48.4	62.7	58.6	50.5	62.8	60.0	52.6
	SHC	26.3	34.9	41.9	27.8	38.7	46.9	29.0	42.1	51.5
	kW	4.20	4.09	3.92	3.97	4.10	4.25	4.28	4.12	4.03
105	TC	58.8	49.9	41.6	60.5	51.9	43.6	61.6	53.5	47.6
	SHC	22.0	29.0	35.8	24.4	32.9	40.7	26.5	36.6	42.3
	kW	4.64	4.46	4.28	4.33	4.52	4.66	4.69	4.57	4.41
115	TC	51.4	41.9	33.8	53.3	43.7	35.9	54.7	45.3	39.2
	SHC	15.7	22.2	29.0	18.1	26.0	33.9	20.4	29.7	35.3
	kW	5.08	4.83	4.63	4.69	4.88	5.14	5.19	4.92	4.77

RAX060 (5 TONS) – UNIT WITH HOT GAS REHEAT SYSTEM IN HOT GAS REHEAT MODE										
TEMP (F) AIR ENT CONDENSER (Edb)		AIR ENTERING EVAPORATOR – Ewb (F)								
		75 Dry Bulb 62.5 Wet Bulb (50% Relative)			75 Dry Bulb 64 Wet Bulb (56% Relative)			75 Dry Bulb 65.3 Wet Bulb (60% Relative)		
		Air Entering Evaporator – Cfm								
		1750	2000	2250	1750	2000	2250	1750	2000	2250
80	TC	13.19	12.95	12.70	14.56	14.30	14.00	15.70	15.44	15.05
	SHC	-2.38	-1.55	-0.65	-4.75	-4.25	-3.69	-6.74	-6.49	-6.21
	kW	3.15	3.16	3.16	3.19	3.20	3.20	3.22	3.23	3.23
75	TC	16.14	15.95	15.71	17.36	17.20	16.84	18.30	18.20	17.81
	SHC	0.44	1.23	2.03	-1.92	-1.36	-0.96	-3.90	-3.50	-3.31
	kW	3.04	3.05	3.06	3.07	3.08	3.09	3.10	3.12	3.12
70	TC	18.90	18.68	18.52	19.97	19.85	19.50	20.86	20.62	20.17
	SHC	3.13	3.80	4.51	0.85	1.39	1.70	-0.97	-0.69	-0.63
	kW	2.92	2.93	2.95	2.96	2.97	2.98	2.98	2.99	3.00
60	TC	23.71	23.48	23.16	24.05	23.98	23.52	24.79	24.47	26.99
	SHC	8.11	8.63	8.88	5.97	6.46	6.58	4.65	4.87	5.94
	kW	3.17	3.23	3.15	3.21	3.26	3.18	3.23	3.12	3.10
50	TC	21.91	16.69	16.62	16.81	16.98	16.92	17.08	17.24	17.17
	SHC	11.51	10.04	9.64	9.77	9.43	8.95	9.30	8.88	8.35
	kW	3.01	3.07	3.11	3.04	3.10	3.15	3.07	3.14	3.18
40	TC	21.91	16.69	16.62	16.81	16.98	16.92	17.08	17.24	17.17
	SHC	11.51	10.04	9.64	9.77	9.43	8.95	9.30	8.88	8.35
	kW	3.39	3.32	3.24	3.14	3.23	3.15	3.18	3.27	3.08

LEGEND

- Edb – Entering Dry-Bulb
- Ewb – Entering Wet-Bulb
- kW – Compressor Motor Power Input
- ldb – Leaving Dry-Bulb
- lwb – Leaving Wet-Bulb
- SHC – Sensible Heat Capacity (1000 Btuh) Gross
- TC – Total Capacity (1000 Btuh) Gross

Table 12 – STATIC PRESSURE ADDERS (IN. WG) (FACTORY OPTIONS AND/OR ACCESSORIES)

3-5 TONS											
CFM	600	900	1200	1400	1600	1800	2000	2200	2400	2600	
1 Electric Heater Module	0.03	0.05	0.07	0.09	0.09	0.10	0.11	0.11	0.12	0.13	
2 Electric Heater Modules	0.13	0.15	0.16	0.16	0.16	0.17	0.17	0.17	0.18	0.18	

3-5-TONS										
CFM	600	800	1000	1250	1500	1750	2000	2250	2500	
Vertical Economizer	0.012	0.020	0.030	0.046	0.066	0.089	0.115	0.145	0.179	
Horizontal Economizer	0.018	0.026	0.037	0.053	0.073	0.096	0.124	0.154	0.189	

All above data for both standard and ultra low leak models, where available.

3-5-TONS										
CFM	600	800	1000	1250	1500	1750	2000	2250	2500	
Hot Gas ReHeat	0.023	0.033	0.042	0.054	0.067	0.080	0.093	0.106	0.120	

3-5-TONS						
Power Exhaust Performance						
Return Duct Static Pressure (in wg)	0.0	0.1	0.2	0.3	0.4	0.5
Vertical Power Exhaust CFM	3239	2974	2642	2244	1780	1249

GENERAL FAN PERFORMANCE NOTES

1. Interpolation is permissible. Do not extrapolate.
2. External static pressure is the static pressure difference between the return duct and the supply duct plus the static pressure caused by any FIOPs or accessories.
3. Tabular data accounts for pressure loss due to clean filters, unit casing, and wet coils. Factory options and accessories may add static pressure losses. Selection software is available, through your salesperson, to help you select the best motor/drive combination for your application.
4. The Fan Performance tables offer motor/drive recommendations. In cases when two motor/drive combinations would work, ICP recommended the lower horsepower option.
5. For information on the electrical properties of ICP motors, please see the Electrical information section of this book.
6. For more information on the performance limits of ICP motors, see the application data section of this book.
7. The EPACT (Energy Policy Act of 1992) regulates energy requirements for specific types of indoor fan motors. Motors regulated by EPACT include any general purpose, T-frame (three-digit, 143 and larger), single-speed, foot mounted, polyphase, squirrel cage induction motors of NEMA (National Electrical Manufacturers Association) design A and B, manufactured for use in the United States. Ranging from 1 to 200 Hp, these continuous-duty motors operate on 230 and 460 volt, 60 Hz power. If a motor does not fit into these specifications, the motor does not have to be replaced by an EPACT compliant energy-efficient motor. Variable-speed motors are exempt from EPACT compliance requirements. Therefore, the indoor fan motors for ICP RAX036-060 units are exempt from these requirements.

FAN PERFORMANCE (DIRECT DRIVE)

Table 13 – RAX036 Vertical Unit – Direct Drive

Speed (Torque) tap	CFM	ESP	BHP
1	900	0.36	0.16
	975	0.27	0.16
	1050	0.19	0.15
	1125	0.11	0.15
	1200	0.04	0.16
	1275	-	-
	1350	-	-
	1425	-	-
	1500	-	-
2	900	0.53	0.22
	975	0.43	0.21
	1050	0.32	0.21
	1125	0.22	0.20
	1200	0.13	0.19
	1275	0.04	0.18
	1350	-	-
	1425	-	-
	1500	-	-
3	900	0.81	0.32
	975	0.70	0.31
	1050	0.60	0.30
	1125	0.49	0.29
	1200	0.38	0.27
	1275	0.27	0.26
	1350	0.18	0.25
	1425	0.10	0.24
	1500	-	-
4	900	1.06	0.42
	975	0.95	0.42
	1050	0.84	0.42
	1125	0.73	0.41
	1200	0.60	0.39
	1275	0.48	0.38
	1350	0.35	0.36
	1425	0.22	0.34
	1500	0.11	0.31
5	900	1.24	0.51
	975	1.19	0.52
	1050	1.14	0.54
	1125	1.08	0.57
	1200	1.03	0.59
	1275	0.98	0.61
	1350	0.93	0.64
	1425	0.88	0.67
	1500	0.82	0.69

Table 14 – RAX036 Horizontal Unit – Direct Drive

Speed (Torque) tap	CFM	ESP	BHP
1	900	0.47	0.21
	975	0.38	0.20
	1050	0.29	0.19
	1125	0.21	0.18
	1200	0.13	0.18
	1275	0.06	0.20
	1350	-	-
	1425	-	-
	1500	-	-
2	900	0.65	0.27
	975	0.54	0.26
	1050	0.44	0.25
	1125	0.33	0.24
	1200	0.23	0.23
	1275	0.13	0.21
	1350	0.02	0.20
	1425	-	-
	1500	-	-
3	900	0.96	0.38
	975	0.84	0.37
	1050	0.73	0.36
	1125	0.61	0.34
	1200	0.50	0.33
	1275	0.38	0.31
	1350	0.26	0.30
	1425	0.15	0.28
	1500	0.04	0.26
4	900	1.17	0.46
	975	1.08	0.46
	1050	0.98	0.46
	1125	0.87	0.45
	1200	0.75	0.44
	1275	0.63	0.42
	1350	0.51	0.40
	1425	0.39	0.39
	1500	0.27	0.37
5	900	1.35	0.52
	975	1.30	0.54
	1050	1.26	0.57
	1125	1.21	0.59
	1200	1.16	0.62
	1275	1.12	0.64
	1350	1.07	0.67
	1425	1.02	0.70
	1500	0.97	0.73

FAN PERFORMANCE (DIRECT DRIVE) (cont.)

Table 15 – RAX048 Vertical Unit – Direct Drive

Speed (Torque) tap	CFM	ESP	BHP
1	1200	0.50	0.32
	1300	0.35	0.31
	1400	0.20	0.29
	1500	–	–
	1600	–	–
	1700	–	–
	1800	–	–
	1900	–	–
	2000	–	–
2	1200	0.63	0.38
	1300	0.46	0.36
	1400	0.30	0.34
	1500	0.15	0.32
	1600	–	–
	1700	–	–
	1800	–	–
	1900	–	–
	2000	–	–
3	1200	0.98	0.56
	1300	0.88	0.59
	1400	0.75	0.59
	1500	0.61	0.56
	1600	0.44	0.53
	1700	0.26	0.53
	1800	0.08	0.48
	1900	–	–
	2000	–	–
4	1200	1.00	0.57
	1300	0.94	0.60
	1400	0.87	0.63
	1500	0.78	0.66
	1600	0.68	0.69
	1700	0.57	0.71
	1800	0.43	0.68
	1900	0.28	0.67
	2000	–	–
5	1200	1.03	0.59
	1300	0.96	0.62
	1400	0.89	0.66
	1500	0.82	0.69
	1600	0.75	0.73
	1700	0.67	0.77
	1800	0.58	0.81
	1900	0.50	0.85
	2000	0.40	0.89

Table 16 – RAX048 Horizontal Unit – Direct Drive

Speed (Torque) tap	CFM	ESP	BHP
1	1200	0.61	0.38
	1300	0.45	0.36
	1400	0.30	0.33
	1500	0.15	0.31
	1600	0.03	0.29
	1700	–	–
	1800	–	–
	1900	–	–
	2000	–	–
2	1200	0.75	0.44
	1300	0.59	0.42
	1400	0.43	0.39
	1500	0.27	0.37
	1600	0.12	0.35
	1700	0.01	0.32
	1800	–	–
	1900	–	–
	2000	–	–
3	1200	1.13	0.59
	1300	1.03	0.62
	1400	0.91	0.63
	1500	0.76	0.61
	1600	0.61	0.59
	1700	0.43	0.59
	1800	0.26	0.54
	1900	0.09	0.51
	2000	–	–
4	1200	1.15	0.60
	1300	1.08	0.64
	1400	1.01	0.67
	1500	0.93	0.70
	1600	0.84	0.73
	1700	0.74	0.75
	1800	0.62	0.75
	1900	0.47	0.73
	2000	0.31	0.71
5	1200	1.16	0.62
	1300	1.10	0.65
	1400	1.04	0.69
	1500	0.97	0.73
	1600	0.90	0.77
	1700	0.84	0.81
	1800	0.76	0.85
	1900	0.69	0.89
	2000	0.61	0.93

FAN PERFORMANCE (DIRECT DRIVE) (cont.)

Table 17 – RAX060 Vertical Unit – Direct Drive

Speed (Torque) tap	CFM	ESP	BHP
1	1500	0.46	0.42
	1625	0.29	0.39
	1750	0.11	0.37
	1875	–	–
	2000	–	–
	2125	–	–
	2250	–	–
	2375	–	–
	2500	–	–
2	1500	0.68	0.54
	1625	0.48	0.51
	1750	0.30	0.48
	1875	0.13	0.45
	2000	–	–
	2125	–	–
	2250	–	–
	2375	–	–
	2500	–	–
3	1500	1.17	0.82
	1625	0.98	0.80
	1750	0.78	0.79
	1875	0.56	0.76
	2000	0.36	0.72
	2125	0.17	0.72
	2250	0.02	0.64
	2375	–	–
	2500	–	–
4	1500	1.29	0.91
	1625	1.14	0.89
	1750	0.96	0.92
	1875	0.75	0.90
	2000	0.53	0.86
	2125	0.32	0.82
	2250	0.12	0.78
	2375	0.01	0.75
	2500	–	–
5	1500	1.36	0.94
	1625	1.24	0.99
	1750	1.10	1.02
	1875	0.93	1.05
	2000	0.74	1.03
	2125	0.53	0.99
	2250	0.31	0.94
	2375	0.08	0.90
	2500	–	0.86

Table 18 – RAX060 Horizontal Unit – Direct Drive

Speed (Torque) tap	CFM	ESP	BHP
1	1500	0.59	0.46
	1625	0.41	0.44
	1750	0.23	0.40
	1875	0.07	0.37
	2000	–	–
	2125	–	–
	2250	–	–
	2375	–	–
	2500	–	–
2	1500	0.83	0.58
	1625	0.63	0.55
	1750	0.44	0.52
	1875	0.26	0.49
	2000	0.08	0.45
	2125	–	–
	2250	–	–
	2375	–	–
	2500	–	–
3	1500	1.34	0.87
	1625	1.17	0.85
	1750	0.97	0.83
	1875	0.76	0.80
	2000	0.55	0.76
	2125	0.34	0.76
	2250	0.17	0.68
	2375	0.04	0.63
	2500	–	–
4	1500	1.47	0.94
	1625	1.33	0.93
	1750	1.17	0.97
	1875	0.98	0.96
	2000	0.77	0.92
	2125	0.56	0.88
	2250	0.35	0.84
	2375	0.16	0.79
	2500	0.01	0.73
5	1500	1.52	0.97
	1625	1.42	1.01
	1750	1.30	1.05
	1875	1.16	1.09
	2000	1.00	1.09
	2125	0.82	1.06
	2250	0.62	1.02
	2375	0.40	0.98
	2500	0.16	0.93

FAN PERFORMANCE (BELT DRIVE) (cont.)

Table 19 – RAX036

1 PHASE

3 TON VERTICAL SUPPLY

CFM	AVAILABLE EXTERNAL STATIC PRESSURE (in. wg)									
	0.2		0.4		0.6		0.8		1.0	
	RPM	BHP	RPM	BHP	RPM	BHP	RPM	BHP	RPM	BHP
900	594	0.15	740	0.25	867	0.37	981	0.52	1084	0.68
975	618	0.17	758	0.28	881	0.40	991	0.55	1092	0.71
1050	642	0.19	777	0.30	896	0.43	1003	0.58	1102	0.75
1125	668	0.22	797	0.34	912	0.47	1017	0.62	1113	0.79
1200	695	0.25	818	0.37	930	0.51	1032	0.66	1126	0.83
1275	722	0.29	841	0.41	949	0.55	1048	0.71	1140	0.88
1350	750	0.33	864	0.46	968	0.60	1065	0.76	1155	0.93
1425	778	0.37	888	0.50	989	0.65	1083	0.81	1171	0.99
1500	807	0.42	913	0.56	1011	0.71	1103	0.87	1188	1.05

CFM	AVAILABLE EXTERNAL STATIC PRESSURE (in. wg)									
	1.2		1.4		1.6		1.8		2.0	
	RPM	BHP	RPM	BHP	RPM	BHP	RPM	BHP	RPM	BHP
900	1180	0.86	1269	1.05	1354	1.25	1434	1.47	–	–
975	1186	0.89	1275	1.08	1358	1.29	–	–	–	–
1050	1194	0.92	1281	1.12	1363	1.32	–	–	–	–
1125	1204	0.97	1289	1.16	1370	1.37	–	–	–	–
1200	1215	1.01	1298	1.21	1378	1.42	–	–	–	–
1275	1227	1.06	1309	1.26	1387	1.47	–	–	–	–
1350	1240	1.12	1321	1.32	–	–	–	–	–	–
1425	1254	1.18	1333	1.38	–	–	–	–	–	–
1500	1270	1.24	1347	1.45	–	–	–	–	–	–

NOTE: For more information, see General Fan Performance Notes.
Boldface indicates field-supplied drive is required.

Medium static 770–1175 RPM, 1.2 BHP max
 High static 1035–1456 RPM, 1.5 BHP max

Table 20 – RAX036

1 PHASE

3 TON HORIZONTAL SUPPLY

CFM	AVAILABLE EXTERNAL STATIC PRESSURE (in. wg)									
	0.2		0.4		0.6		0.8		1.0	
	RPM	BHP	RPM	BHP	RPM	BHP	RPM	BHP	RPM	BHP
900	574	0.13	707	0.23	817	0.34	913	0.47	999	0.61
975	597	0.15	727	0.25	835	0.37	929	0.50	1015	0.64
1050	621	0.18	747	0.28	853	0.40	946	0.53	1030	0.68
1125	646	0.20	768	0.31	872	0.43	964	0.57	1047	0.72
1200	671	0.23	790	0.34	892	0.47	982	0.61	1064	0.76
1275	696	0.26	812	0.38	912	0.51	1001	0.65	1082	0.81
1350	723	0.30	835	0.42	933	0.55	1020	0.70	1100	0.86
1425	749	0.34	859	0.46	955	0.60	1040	0.75	1119	0.91
1500	776	0.38	883	0.51	977	0.65	1061	0.80	1138	0.97

CFM	AVAILABLE EXTERNAL STATIC PRESSURE (in. wg)									
	1.2		1.4		1.6		1.8		2.0	
	RPM	BHP	RPM	BHP	RPM	BHP	RPM	BHP	RPM	BHP
900	1078	0.77	1151	0.93	1220	1.11	1284	1.30	1346	1.49
975	1093	0.80	1165	0.97	1233	1.15	1297	1.33	–	–
1050	1108	0.84	1180	1.01	1247	1.19	1311	1.38	–	–
1125	1123	0.88	1195	1.05	1261	1.23	1325	1.42	–	–
1200	1140	0.92	1210	1.10	1276	1.28	1339	1.47	–	–
1275	1157	0.97	1226	1.15	1292	1.33	–	–	–	–
1350	1174	1.02	1243	1.20	1308	1.39	–	–	–	–
1425	1192	1.08	1260	1.26	1325	1.45	–	–	–	–
1500	1210	1.14	1278	1.33	–	–	–	–	–	–

NOTE: For more information, see General Fan Performance Notes.
Boldface indicates field-supplied drive is required.

Medium static 770–1175 RPM, 1.2 BHP max
 High static 1035–1456 RPM, 1.5 BHP max

FAN PERFORMANCE (BELT DRIVE) (cont.)

Table 21 – RAX036

3 PHASE

3 TON VERTICAL SUPPLY

CFM	Available External Static Pressure (in. wg)									
	0.2		0.4		0.6		0.8		1.0	
	RPM	BHP	RPM	BHP	RPM	BHP	RPM	BHP	RPM	BHP
900	594	0.15	740	0.25	867	0.37	981	0.52	1084	0.68
975	618	0.17	758	0.28	881	0.40	991	0.55	1092	0.71
1050	642	0.19	777	0.30	896	0.43	1003	0.58	1102	0.75
1125	668	0.22	797	0.34	912	0.47	1017	0.62	1113	0.79
1200	695	0.25	818	0.37	930	0.51	1032	0.66	1126	0.83
1275	722	0.29	841	0.41	949	0.55	1048	0.71	1140	0.88
1350	750	0.33	864	0.46	968	0.60	1065	0.76	1155	0.93
1425	778	0.37	888	0.50	989	0.65	1083	0.81	1171	0.99
1500	807	0.42	913	0.56	1011	0.71	1103	0.87	1188	1.05

CFM	Available External Static Pressure (in. wg)									
	1.2		1.4		1.6		1.8		2.0	
	RPM	BHP	RPM	BHP	RPM	BHP	RPM	BHP	RPM	BHP
900	1180	0.86	1269	1.05	1354	1.25	1434	1.47	1511	1.70
975	1186	0.89	1275	1.08	1358	1.29	1437	1.51	1513	1.74
1050	1194	0.92	1281	1.12	1363	1.32	1441	1.54	1516	1.78
1125	1204	0.97	1289	1.16	1370	1.37	1447	1.59	1520	1.82
1200	1215	1.01	1298	1.21	1378	1.42	1454	1.64	1526	1.87
1275	1227	1.06	1309	1.26	1387	1.47	1462	1.69	1533	1.92
1350	1240	1.12	1321	1.32	1397	1.53	1471	1.75	1541	1.99
1425	1254	1.18	1333	1.38	1409	1.59	1481	1.82	-	-
1500	1270	1.24	1347	1.45	1421	1.66	1492	1.89	-	-

NOTE: For more information, see General Fan Performance Notes.
Boldface indicates field-supplied drive is required.

Medium static 770–1175 RPM, 1.5 BHP max v
 High static 1035 – 1466 RPM, 2.9 BHP max

Table 22 – RAX036

3 PHASE

3 TON HORIZONTAL SUPPLY

CFM	Available External Static Pressure (in. wg)									
	0.2		0.4		0.6		0.8		1.0	
	RPM	BHP	RPM	BHP	RPM	BHP	RPM	BHP	RPM	BHP
900	574	0.13	707	0.23	817	0.34	913	0.47	999	0.61
975	597	0.15	727	0.25	835	0.37	929	0.50	1015	0.64
1050	621	0.18	747	0.28	853	0.40	946	0.53	1030	0.68
1125	646	0.20	768	0.31	872	0.43	964	0.57	1047	0.72
1200	671	0.23	790	0.34	892	0.47	982	0.61	1064	0.76
1275	696	0.26	812	0.38	912	0.51	1001	0.65	1082	0.81
1350	723	0.30	835	0.42	933	0.55	1020	0.70	1100	0.86
1425	749	0.34	859	0.46	955	0.60	1040	0.75	1119	0.91
1500	776	0.38	883	0.51	977	0.65	1061	0.80	1138	0.97

CFM	Available External Static Pressure (in. wg)									
	1.2		1.4		1.6		1.8		2.0	
	RPM	BHP	RPM	BHP	RPM	BHP	RPM	BHP	RPM	BHP
900	1078	0.77	1151	0.93	1220	1.11	1284	1.30	1346	1.49
975	1093	0.80	1165	0.97	1233	1.15	1297	1.33	1358	1.53
1050	1108	0.84	1180	1.01	1247	1.19	1311	1.38	1371	1.58
1125	1123	0.88	1195	1.05	1261	1.23	1325	1.42	1385	1.62
1200	1140	0.92	1210	1.10	1276	1.28	1339	1.47	1399	1.68
1275	1157	0.97	1226	1.15	1292	1.33	1354	1.53	1414	1.73
1350	1174	1.02	1243	1.20	1308	1.39	1370	1.59	1429	1.80
1425	1192	1.08	1260	1.26	1325	1.45	1386	1.65	1444	1.86
1500	1210	1.14	1278	1.33	1342	1.52	1403	1.72	1461	1.93

NOTE: For more information, see General Fan Performance Notes.
Boldface indicates field-supplied drive is required.

Medium static 770–1175 RPM, 1.5 BHP max v
 High static 1035 – 1466 RPM, 2.9 BHP max

FAN PERFORMANCE (BELT DRIVE) (cont.)

Table 23 – RAX048

1 PHASE

4 TON VERTICAL SUPPLY

CFM	AVAILABLE EXTERNAL STATIC PRESSURE (in. wg)									
	0.2		0.4		0.6		0.8		1.0	
	RPM	BHP	RPM	BHP	RPM	BHP	RPM	BHP	RPM	BHP
1200	695	0.25	818	0.37	930	0.51	1032	0.66	1126	0.83
1300	731	0.30	849	0.43	955	0.57	1053	0.72	1145	0.89
1400	769	0.36	880	0.49	982	0.63	1077	0.79	1166	0.97
1500	807	0.42	913	0.56	1011	0.71	1103	0.87	1188	1.05
1600	847	0.49	948	0.63	1042	0.79	1130	0.96	1213	1.14
1700	887	0.57	983	0.72	1073	0.88	1158	1.06	1239	1.24
1800	928	0.66	1020	0.82	1106	0.98	1188	1.16	1266	1.35
1900	969	0.76	1057	0.92	1140	1.09	1219	1.28	1295	1.48
2000	1010	0.87	1095	1.04	1175	1.21	1251	1.41	–	–

CFM	AVAILABLE EXTERNAL STATIC PRESSURE (in. wg)									
	1.2		1.4		1.6		1.8		2.0	
	RPM	BHP	RPM	BHP	RPM	BHP	RPM	BHP	RPM	BHP
1200	1215	1.01	1298	1.21	1378	1.42	–	–	–	–
1300	1231	1.08	1313	1.28	1390	1.49	–	–	–	–
1400	1249	1.16	1329	1.36	–	–	–	–	–	–
1500	1270	1.24	1347	1.45	–	–	–	–	–	–
1600	1292	1.34	–	–	–	–	–	–	–	–
1700	1315	1.44	–	–	–	–	–	–	–	–
1800	–	–	–	–	–	–	–	–	–	–
1900	–	–	–	–	–	–	–	–	–	–
2000	–	–	–	–	–	–	–	–	–	–

NOTE: For more information, see General Fan Performance Notes.
Boldface indicates field-supplied drive is required.

Medium static 770–1175 RPM, 1.2 BHP max
 High static 1035–1456 RPM, 1.5 BHP max

Table 24 – RAX048

1 PHASE

4 TON HORIZONTAL SUPPLY

CFM	AVAILABLE EXTERNAL STATIC PRESSURE (in. wg)									
	0.2		0.4		0.6		0.8		1.0	
	RPM	BHP	RPM	BHP	RPM	BHP	RPM	BHP	RPM	BHP
1200	671	0.23	790	0.34	892	0.47	982	0.61	1064	0.76
1300	705	0.28	820	0.39	919	0.52	1007	0.67	1088	0.82
1400	740	0.33	851	0.45	947	0.58	1034	0.73	1113	0.89
1500	776	0.38	883	0.51	977	0.65	1061	0.80	1138	0.97
1600	813	0.45	916	0.58	1007	0.73	1089	0.89	1165	1.05
1700	851	0.52	949	0.66	1038	0.81	1118	0.97	1192	1.15
1800	888	0.60	984	0.75	1069	0.90	1148	1.07	1221	1.25
1900	927	0.69	1019	0.84	1102	1.00	1179	1.18	1250	1.36
2000	965	0.78	1054	0.94	1135	1.11	1210	1.29	1280	1.48

CFM	AVAILABLE EXTERNAL STATIC PRESSURE (in. wg)									
	1.2		1.4		1.6		1.8		2.0	
	RPM	BHP	RPM	BHP	RPM	BHP	RPM	BHP	RPM	BHP
1200	1140	0.92	1210	1.10	1276	1.28	1339	1.47	–	–
1300	1162	0.99	1232	1.16	1297	1.35	–	–	–	–
1400	1186	1.06	1254	1.24	1319	1.43	–	–	–	–
1500	1210	1.14	1278	1.33	–	–	–	–	–	–
1600	1236	1.23	1302	1.42	–	–	–	–	–	–
1700	1262	1.33	–	–	–	–	–	–	–	–
1800	1289	1.44	–	–	–	–	–	–	–	–
1900	–	–	–	–	–	–	–	–	–	–
2000	–	–	–	–	–	–	–	–	–	–

NOTE: For more information, see General Fan Performance Notes.
Boldface indicates field-supplied drive is required.

Medium static 770–1175 RPM, 1.2 BHP max
 High static 1035–1456 RPM, 1.5 BHP max

FAN PERFORMANCE (BELT DRIVE) (cont.)

Table 25 – RAX048

3 PHASE

4 TON VERTICAL SUPPLY

CFM	Available External Static Pressure (in. wg)									
	0.2		0.4		0.6		0.8		1.0	
	RPM	BHP	RPM	BHP	RPM	BHP	RPM	BHP	RPM	BHP
1200	695	0.25	818	0.37	930	0.51	1032	0.66	1126	0.83
1300	731	0.30	849	0.43	955	0.57	1053	0.72	1145	0.89
1400	769	0.36	880	0.49	982	0.63	1077	0.79	1166	0.97
1500	807	0.42	913	0.56	1011	0.71	1103	0.87	1188	1.05
1600	847	0.49	948	0.63	1042	0.79	1130	0.96	1213	1.14
1700	887	0.57	983	0.72	1073	0.88	1158	1.06	1239	1.24
1800	928	0.66	1020	0.82	1106	0.98	1188	1.16	1266	1.35
1900	969	0.76	1057	0.92	1140	1.09	1219	1.28	1295	1.48
2000	1010	0.87	1095	1.04	1175	1.21	1251	1.41	1325	1.61

CFM	Available External Static Pressure (in. wg)									
	1.2		1.4		1.6		1.8		2.0	
	RPM	BHP	RPM	BHP	RPM	BHP	RPM	BHP	RPM	BHP
1200	1215	1.01	1298	1.21	1378	1.42	1454	1.64	1526	1.87
1300	1231	1.08	1313	1.28	1390	1.49	1465	1.71	1536	1.94
1400	1249	1.16	1329	1.36	1405	1.57	1478	1.79	1547	2.03
1500	1270	1.24	1347	1.45	1421	1.66	1492	1.89	1561	2.13
1600	1292	1.34	1367	1.54	1440	1.76	1509	1.99	1576	2.23
1700	1315	1.44	1389	1.65	1459	1.88	1527	2.11	1593	2.35
1800	1341	1.56	1412	1.77	1481	2.00	1547	2.23	1612	2.48
1900	1367	1.68	1437	1.90	1504	2.13	1569	2.37	1632	2.62
2000	1395	1.82	1463	2.04	1528	2.28	1591	2.52	1653	2.77

NOTE: For more information, see General Fan Performance Notes.
Boldface indicates field-supplied drive is required.

Medium static 770–1175 RPM, 1.5 BHP max v
 High static 1035 – 1466 RPM, 2.9 BHP max

Table 26 – RAX048

3 PHASE

4 TON HORIZONTAL SUPPLY

CFM	Available External Static Pressure (in. wg)									
	0.2		0.4		0.6		0.8		1.0	
	RPM	BHP	RPM	BHP	RPM	BHP	RPM	BHP	RPM	BHP
1200	671	0.23	790	0.34	892	0.47	982	0.61	1064	0.76
1300	705	0.28	820	0.39	919	0.52	1007	0.67	1088	0.82
1400	740	0.33	851	0.45	947	0.58	1034	0.73	1113	0.89
1500	776	0.38	883	0.51	977	0.65	1061	0.80	1138	0.97
1600	813	0.45	916	0.58	1007	0.73	1089	0.89	1165	1.05
1700	851	0.52	949	0.66	1038	0.81	1118	0.97	1192	1.15
1800	888	0.60	984	0.75	1069	0.90	1148	1.07	1221	1.25
1900	927	0.69	1019	0.84	1102	1.00	1179	1.18	1250	1.36
2000	965	0.78	1054	0.94	1135	1.11	1210	1.29	1280	1.48

CFM	Available External Static Pressure (in. wg)									
	1.2		1.4		1.6		1.8		2.0	
	RPM	BHP	RPM	BHP	RPM	BHP	RPM	BHP	RPM	BHP
1200	1140	0.92	1210	1.10	1276	1.28	1339	1.47	1399	1.68
1300	1162	0.99	1232	1.16	1297	1.35	1360	1.55	1419	1.75
1400	1186	1.06	1254	1.24	1319	1.43	1381	1.63	1439	1.84
1500	1210	1.14	1278	1.33	1342	1.52	1403	1.72	1461	1.93
1600	1236	1.23	1302	1.42	1365	1.62	1425	1.82	1483	2.04
1700	1262	1.33	1328	1.52	1390	1.72	1449	1.93	1505	2.15
1800	1289	1.44	1354	1.63	1415	1.84	1473	2.05	1529	2.27
1900	1317	1.55	1380	1.75	1441	1.96	1498	2.18	1553	2.41
2000	1345	1.68	1408	1.88	1467	2.10	1524	2.32	1579	2.55

NOTE: For more information, see General Fan Performance Notes.
Boldface indicates field-supplied drive is required.

Medium static 770–1175 RPM, 1.5 BHP max v
 High static 1035 – 1466 RPM, 2.9 BHP max

FAN PERFORMANCE (BELT DRIVE) (cont.)

Table 27 – RAX060

1 PHASE

5 TON VERTICAL SUPPLY

CFM	AVAILABLE EXTERNAL STATIC PRESSURE (in. wg)									
	0.2		0.4		0.6		0.8		1.0	
	RPM	BHP	RPM	BHP	RPM	BHP	RPM	BHP	RPM	BHP
1500	794	0.41	902	0.55	993	0.69	1074	0.85	1147	1.00
1625	840	0.49	945	0.64	1034	0.80	1113	0.96	1185	1.13
1750	888	0.59	988	0.75	1075	0.92	1153	1.09	1223	1.26
1875	936	0.70	1033	0.87	1117	1.05	1193	1.23	1263	1.41
2000	984	0.82	1078	1.00	1160	1.19	1235	1.39	–	–
2125	1033	0.96	1124	1.15	1204	1.35	–	–	–	–
2250	1083	1.11	1170	1.32	1248	1.53	–	–	–	–
2375	1133	1.28	1217	1.50	–	–	–	–	–	–
2500	1183	1.47	–	–	–	–	–	–	–	–

CFM	AVAILABLE EXTERNAL STATIC PRESSURE (in. wg)									
	1.2		1.4		1.6		1.8		2.0	
	RPM	BHP	RPM	BHP	RPM	BHP	RPM	BHP	RPM	BHP
1500	1214	1.16	1277	1.33	1336	1.50	–	–	–	–
1625	1251	1.30	1313	1.47	–	–	–	–	–	–
1750	1289	1.44	–	–	–	–	–	–	–	–
1875	–	–	–	–	–	–	–	–	–	–
2000	–	–	–	–	–	–	–	–	–	–
2125	–	–	–	–	–	–	–	–	–	–
2250	–	–	–	–	–	–	–	–	–	–
2375	–	–	–	–	–	–	–	–	–	–
2500	–	–	–	–	–	–	–	–	–	–

NOTE: For more information, see General Fan Performance Notes.
Boldface indicates field-supplied drive is required.

■ Medium static 1035–1466 RPM, 1.2 BHP max

Table 28 – RAX060

1 PHASE

5 TON HORIZONTAL SUPPLY

CFM	AVAILABLE EXTERNAL STATIC PRESSURE (in. wg)									
	0.2		0.4		0.6		0.8		1.0	
	RPM	BHP	RPM	BHP	RPM	BHP	RPM	BHP	RPM	BHP
1500	725	0.33	840	0.46	937	0.60	1023	0.75	1101	0.90
1625	765	0.40	876	0.54	970	0.68	1054	0.84	1131	1.00
1750	806	0.48	912	0.63	1004	0.78	1087	0.94	1162	1.11
1875	847	0.57	950	0.72	1039	0.88	1120	1.05	1194	1.23
2000	889	0.66	988	0.83	1075	1.00	1154	1.18	1226	1.36
2125	931	0.78	1027	0.95	1112	1.13	1189	1.31	1260	1.50
2250	974	0.90	1067	1.08	1149	1.27	1224	1.46	–	–
2375	1018	1.03	1107	1.23	1187	1.43	–	–	–	–
2500	1061	1.19	1148	1.39	–	–	–	–	–	–

CFM	AVAILABLE EXTERNAL STATIC PRESSURE (in. wg)									
	1.2		1.4		1.6		1.8		2.0	
	RPM	BHP	RPM	BHP	RPM	BHP	RPM	BHP	RPM	BHP
1500	1172	1.06	1239	1.23	1302	1.40	–	–	–	–
1625	1201	1.16	1267	1.34	1329	1.52	–	–	–	–
1750	1231	1.28	1296	1.46	–	–	–	–	–	–
1875	1262	1.41	–	–	–	–	–	–	–	–
2000	–	–	–	–	–	–	–	–	–	–
2125	–	–	–	–	–	–	–	–	–	–
2250	–	–	–	–	–	–	–	–	–	–
2375	–	–	–	–	–	–	–	–	–	–
2500	–	–	–	–	–	–	–	–	–	–

NOTE: For more information, see General Fan Performance Notes.
Boldface indicates field-supplied drive is required.

■ Medium static 1035–1466 RPM, 1.2 BHP max

FAN PERFORMANCE (BELT DRIVE) (cont.)

Table 29 – RAX060

3 PHASE

5 TON VERTICAL SUPPLY

CFM	Available External Static Pressure (in. wg)									
	0.2		0.4		0.6		0.8		1.0	
	RPM	BHP	RPM	BHP	RPM	BHP	RPM	BHP	RPM	BHP
1500	794	0.41	902	0.55	993	0.69	1074	0.85	1147	1.00
1625	840	0.49	945	0.64	1034	0.80	1113	0.96	1185	1.13
1750	888	0.59	988	0.75	1075	0.92	1153	1.09	1223	1.26
1875	936	0.70	1033	0.87	1117	1.05	1193	1.23	1263	1.41
2000	984	0.82	1078	1.00	1160	1.19	1235	1.39	1303	1.58
2125	1033	0.96	1124	1.15	1204	1.35	1277	1.56	1343	1.76
2250	1083	1.11	1170	1.32	1248	1.53	1319	1.74	1385	1.96
2375	1133	1.28	1217	1.50	1293	1.72	1363	1.95	1427	2.17
2500	1183	1.47	1265	1.70	1339	1.93	1406	2.17	1470	2.41

CFM	Available External Static Pressure (in. wg)									
	1.2		1.4		1.6		1.8		2.0	
	RPM	BHP	RPM	BHP	RPM	BHP	RPM	BHP	RPM	BHP
1500	1214	1.16	1277	1.33	1336	1.50	1392	1.67	1445	1.85
1625	1251	1.30	1313	1.47	1371	1.65	1427	1.83	1479	2.02
1750	1289	1.44	1350	1.63	1407	1.81	1462	2.01	1514	2.20
1875	1327	1.60	1387	1.80	1444	1.99	1498	2.19	1550	2.40
2000	1366	1.78	1426	1.98	1482	2.19	1535	2.40	1586	2.61
2125	1406	1.97	1464	2.18	1520	2.40	1573	2.62	1623	2.84
2250	1446	2.18	1504	2.40	1559	2.62	1611	2.85	1661	3.09
2375	1487	2.40	1544	2.63	1598	2.87	1650	3.11	-	-
2500	1529	2.64	1585	2.89	1638	3.13	-	-	-	-

NOTE: For more information, see General Fan Performance Notes.
Boldface indicates field-supplied drive is required.

Medium static 770–1175 RPM, 1.5 BHP max v
 High static 1035 – 1466 RPM, 2.9 BHP max

Table 30 – RAX060

3 PHASE

5 TON HORIZONTAL SUPPLY

CFM	Available External Static Pressure (in. wg)									
	0.2		0.4		0.6		0.8		1.0	
	RPM	BHP	RPM	BHP	RPM	BHP	RPM	BHP	RPM	BHP
1500	725	0.33	840	0.46	937	0.60	1023	0.75	1101	0.90
1625	765	0.40	876	0.54	970	0.68	1054	0.84	1131	1.00
1750	806	0.48	912	0.63	1004	0.78	1087	0.94	1162	1.11
1875	847	0.57	950	0.72	1039	0.88	1120	1.05	1194	1.23
2000	889	0.66	988	0.83	1075	1.00	1154	1.18	1226	1.36
2125	931	0.78	1027	0.95	1112	1.13	1189	1.31	1260	1.50
2250	974	0.90	1067	1.08	1149	1.27	1224	1.46	1294	1.66
2375	1018	1.03	1107	1.23	1187	1.43	1261	1.63	1329	1.84
2500	1061	1.19	1148	1.39	1226	1.59	1297	1.81	1364	2.02

CFM	Available External Static Pressure (in. wg)									
	1.2		1.4		1.6		1.8		2.0	2.0
	RPM	BHP	RPM	BHP	RPM	BHP	RPM	BHP	RPM	BHP
1500	1172	1.06	1239	1.23	1302	1.40	1361	1.58	1418	1.77
1625	1201	1.16	1267	1.34	1329	1.52	1388	1.71	1444	1.90
1750	1231	1.28	1296	1.46	1358	1.65	1416	1.84	1472	2.04
1875	1262	1.41	1326	1.60	1387	1.79	1445	1.99	1499	2.20
2000	1294	1.55	1357	1.74	1417	1.95	1474	2.15	1528	2.36
2125	1326	1.70	1388	1.90	1447	2.11	1504	2.33	1557	2.55
2250	1359	1.87	1420	2.08	1479	2.29	1534	2.51	1587	2.74
2375	1393	2.05	1453	2.27	1511	2.49	1566	2.72	1618	2.95
2500	1427	2.24	1487	2.47	1543	2.70	1597	2.94	1649	3.18

NOTE: For more information, see General Fan Performance Notes.
Boldface indicates field-supplied drive is required.

Medium static 770–1175 RPM, 1.5 BHP max v
 High static 1035 – 1466 RPM, 2.9 BHP max

FAN PERFORMANCE (cont.)

Table 31 – PULLEY ADJUSTMENT – BELT DRIVE

UNIT		MOTOR/DRIVE COMBO	MOTOR PULLEY TURNS OPEN										
			0	0.5	1	1.5	2	2.5	3	3.5	4	4.5	5
36	1 phase	Medium Static	1175	1135	1094	1054	1013	973	932	892	851	811	770
		High Static	1466	1423	1380	1337	1294	1251	1207	1164	1121	1078	1035
48		Medium Static	1175	1135	1094	1054	1013	973	932	892	851	811	770
		High Static	1466	1423	1380	1337	1294	1251	1207	1164	1121	1078	1035
60		Medium Static	1466	1423	1380	1337	1294	1251	1207	1164	1121	1078	1035
		High Static	N/A	N/A	N/A	N/A	N/A	N/A	N/A	N/A	N/A	N/A	N/A
36	3 phase	Medium Static	1175	1135	1094	1054	1013	973	932	892	851	811	770
		High Static	1466	1423	1380	1337	1294	1251	1207	1164	1121	1078	1035
48		Medium Static	1303	1265	1226	1188	1150	1112	1073	1035	997	958	920
		High Static	1639	1596	1553	1510	1467	1424	1380	1337	1294	1251	1208
60		Medium Static	1466	1423	1380	1337	1294	1251	1207	1164	1121	1078	1035
		High Static	1687	1649	1610	1572	1533	1495	1457	1418	1380	1341	1303

NOTE: Do not adjust pulley further than 5 turns open.

■ – Factory settings

N/A – Not Available

ELECTRICAL INFORMATION

Table 32 – RAX036 SINGLE STAGE COOLING WITH SINGLE SPEED INDOOR FAN MOTOR 3 TONS

V-Ph-Hz	UNIT VOLTAGE		COMP 1		OFM (ea)		IFM		
	RANGE		RLA	LRA	WATTS	FLA	TYPE	EFF at Full Load	FLA
	MIN	MAX							
208-1-60	187	253	16.6	79	190	1.0	DD-STD	78%	7.4
					190	1.0	MED	67%	4.9
					190	1.0	HIGH	76%	7.0
230-1-60	187	253	16.6	79	190	1.0	DD-STD	78%	7.4
					190	1.0	MED	67%	4.9
					190	1.0	HIGH	76%	7.0
208-3-60	187	253	10.4	73	190	1.0	DD-STD	78%	7.4
					190	1.0	MED	87%	5.2
					190	1.0	HIGH	89%	8.4
230-3-60	187	253	10.4	73	190	1.0	DD-STD	78%	7.4
					190	1.0	MED	87%	4.9
					190	1.0	HIGH	89%	8.3
460-3-60	414	506	5.8	38	190	0.5	DD-STD	78%	4.0
					190	0.5	MED	87%	2.5
					190	0.5	HIGH	89%	4.2
575-3-60	518	633	3.8	37	190	0.5	DD-STD	78%	4.0
					190	0.5	MED	72%	1.6
					190	0.5	HIGH	77%	2.8

Table 33 – RAX048 SINGLE STAGE COOLING WITH SINGLE SPEED INDOOR FAN MOTOR 4 TONS

V-Ph-Hz	UNIT VOLTAGE		COMP 1		OFM (ea)		IFM		
	RANGE		RLA	LRA	WATTS	FLA	TYPE	EFF at Full Load	FLA
	MIN	MAX							
208-1-60	187	253	21.8	117	325	1.5	DD-STD	78%	7.4
					325	1.5	MED	67%	4.9
					325	1.5	HIGH	76%	7.0
230-1-60	187	253	21.8	117	325	1.5	DD-STD	78%	7.4
					325	1.5	MED	67%	4.9
					325	1.5	HIGH	76%	7.0
208-3-60	187	253	13.7	83	325	1.5	DD-STD	78%	7.4
					325	1.5	MED	87%	5.2
					325	1.5	HIGH	89%	8.4
230-3-60	187	253	13.7	83	325	1.5	DD-STD	78%	7.4
					325	1.5	MED	87%	4.9
					325	1.5	HIGH	89%	8.3
460-3-60	414	506	6.2	41	325	0.8	DD-STD	78%	4.0
					325	0.8	MED	87%	2.5
					325	0.8	HIGH	89%	4.2
575-3-60	518	633	4.8	33	325	0.6	DD-STD	78%	4.0
					325	0.6	MED	72%	1.6
					325	0.6	HIGH	77%	2.8

Table 34 – RAX060 SINGLE STAGE COOLING WITH SINGLE SPEED INDOOR FAN MOTOR 5 TONS

V-Ph-Hz	UNIT VOLTAGE		COMP 1		OFM (ea)		IFM		
	RANGE		RLA	LRA	WATTS	FLA	TYPE	EFF at Full Load	FLA
	MIN	MAX							
208-1-60	187	253	25.0	134	325	1.4	DD-STD	78%	7.4
					325	1.4	MED	67%	4.9
					325	1.4	HIGH	76%	7.0
230-1-60	187	253	25.0	134	325	1.4	DD-STD	78%	7.4
					325	1.4	MED	67%	4.9
					325	1.4	HIGH	76%	7.0
208-3-60	187	253	15.9	110	325	1.4	DD-STD	78%	7.4
					325	1.4	MED	89%	8.4
					325	1.4	HIGH	89%	8.4
230-3-60	187	253	15.9	110	325	1.4	DD-STD	78%	7.4
					325	1.4	MED	89%	8.3
					325	1.4	HIGH	89%	8.3
460-3-60	414	506	7.0	52	325	0.9	DD-STD	78%	4.0
					325	0.9	MED	89%	4.2
					325	0.9	HIGH	89%	4.2
575-3-60	518	633	5.1	40	325	0.9	DD-STD	78%	4.0
					325	0.9	MED	77%	2.8
					325	0.9	HIGH	77%	2.8

ELECTRIC HEAT – ELECTRICAL INFORMATION

Table 35 – RAX036

WITHOUT FACTORY INSTALLED NON-FUSED DISCONNECT

NOM. V-PH-Hz.	IFM TYPE	ELECTRIC HEATER PART NUMBER CRHEATERXXXXXX	NOM PWR (kW)	APP PWR (kW)	SINGLE POINT KIT PART NUMBER CRSINGLEXXXXXX			
					NO C.O. or UNPWRD C.O.		w/PWRD C.O.	
					NO P.E.	w/P.E. (pwrd fr/unit)	NO P.E.	w/P.E. (pwrd fr/unit)
208/230-1-60	DD-STD	101A00	4.4	3.3/4.0	-	-	NA	NA
		102A00	6.5	4.9/6.0	-	-	NA	NA
		103B00	8.7	6.5/8.0	037	037	NA	NA
		104B00	10.5	7.9/9.6	040	040	NA	NA
		102A00,102A00	13.0	9.8/11.9	040	040	NA	NA
	MED	101A00	4.4	3.3/4.0	-	-	NA	NA
		102A00	6.5	4.9/6.0	-	-	NA	NA
		103B00	8.7	6.5/8.0	037	037	NA	NA
		104B00	10.5	7.9/9.6	040	040	NA	NA
		102A00,102A00	13.0	9.8/11.9	040	040	NA	NA
	HIGH	101A00	4.4	3.3/4.0	-	-	NA	NA
		102A00	6.5	4.9/6.0	-	-	NA	NA
103B00		8.7	6.5/8.0	037	037	NA	NA	
104B00		10.5	7.9/9.6	040	040	NA	NA	
102A00,102A00		13.0	9.8/11.9	040	040	NA	NA	
208/230-3-60	DD-STD	101A00	4.4	3.3/4.0	-	-	-	-
		102A00	6.5	4.9/6.0	-	-	-	-
		103B00	8.7	6.5/8.0	-	-	-	-
		104B00	10.5	7.9/9.6	-	-	-	-
		105A00	16.0	12.0/14.7	037	037	038	038
	MED	101A00	4.4	3.3/4.0	-	-	-	-
		102A00	6.5	4.9/6.0	-	-	-	-
		103B00	8.7	6.5/8.0	-	-	-	-
		104B00	10.5	7.9/9.6	-	-	-	-
		105A00	16.0	12.0/14.7	037	037	038	038
	HIGH	101A00	4.4	3.3/4.0	-	-	-	-
		102A00	6.5	4.9/6.0	-	-	-	-
		103B00	8.7	6.5/8.0	-	-	-	-
		104B00	10.5	7.9/9.6	-	-	-	037
		105A00	16.0	12.0/14.7	037	038	038	038
460-3-60	DD-STD	106A00	6.0	5.5	-	-	-	-
		107A00	8.8	8.1	-	-	-	-
		108A00	11.5	10.6	-	-	-	-
		109A00	14.0	12.9	-	-	-	-
	MED	106A00	6.0	5.5	-	-	-	-
		107A00	8.8	8.1	-	-	-	-
		108A00	11.5	10.6	-	-	-	-
		109A00	14.0	12.9	-	-	-	-
	HIGH	106A00	6.0	5.5	-	-	-	-
		107A00	8.8	8.1	-	-	-	-
		108A00	11.5	10.6	-	-	-	-
		109A00	14.0	12.9	-	-	-	-

LEGEND:

- No Single Point Kit required
- APP PWR - 208 / 230V / 460V / 575V
- C.O. - Convenience outlet
- IFM - Indoor fan motor
- NA - Not Available
- NOM PWR - 240V / 480V / 600V
- P.E. - Power exhaust
- PWRD - Powered convenience outlet
- UNPWRD - Unpowered convenience outlet

ELECTRIC HEAT – ELECTRICAL INFORMATION

Table 36 – RAX048

WITHOUT FACTORY INSTALLED NON-FUSED DISCONNECT

NOM. V-PH-Hz.	IFM TYPE	ELECTRIC HEATER PART NUMBER CRHEATERXXXXXX	NOM PWR (kW)	APP PWR (kW)	SINGLE POINT KIT PART NUMBER CRSINGLEXXXXXX			
					NO C.O. or UNPWRD C.O.		w/PWRD C.O.	
					NO P.E.	w/P.E. (pwrd fr/unit)	NO P.E.	w/P.E. (pwrd fr/unit)
208/230-1-60	DD-STD	101A00	4.4	3.3/4.0	-	-	NA	NA
		103B00	8.7	6.5/8.0	037	037	NA	NA
		102A00,102A00	13.0	9.8/11.9	040	040	NA	NA
		103B00,103B00	17.4	13.1/16.0	040	040	NA	NA
		104B00,104B00	21.0	15.8/19.3	040	040	NA	NA
	MED	101A00	4.4	3.3/4.0	-	-	NA	NA
		103B00	8.7	6.5/8.0	037	037	NA	NA
		102A00,102A00	13.0	9.8/11.9	040	040	NA	NA
		103B00,103B00	17.4	13.1/16.0	040	040	NA	NA
		104B00,104B00	21.0	15.8/19.3	040	040	NA	NA
	HIGH	101A00	4.4	3.3/4.0	-	-	NA	NA
		103B00	8.7	6.5/8.0	037	037	NA	NA
		102A00,102A00	13.0	9.8/11.9	040	040	NA	NA
		103B00,103B00	17.4	13.1/16.0	040	040	NA	NA
		104B00,104B00	21.0	15.8/19.3	040	040	NA	NA
208/230-3-60	DD-STD	102A00	6.5	4.9/6.0	-	-	-	-
		103B00	8.7	6.5/8.0	-	-	-	-
		105A00	16.0	12.0/14.7	037	037	038	038
		104B00,104B00	21.0	15.8/19.3	038	038	038	038
	MED	102A00	6.5	4.9/6.0	-	-	-	-
		103B00	8.7	6.5/8.0	-	-	-	-
		105A00	16.0	12.0/14.7	037	037	038	038
		104B00,104B00	21.0	15.8/19.3	038	038	038	038
	HIGH	102A00	6.5	4.9/6.0	-	-	-	-
		103B00	8.7	6.5/8.0	-	-	-	-
		105A00	16.0	12.0/14.7	037	038	038	038
		104B00,104B00	21.0	15.8/19.3	038	038	038	038
460-3-60	DD-STD	106A00	6.0	5.5	-	-	-	-
		108A00	11.5	10.6	-	-	-	-
		109A00	14.0	12.9	-	-	-	-
		108A00,108A00	23.0	21.1	037	037	037	037
	MED	106A00	6.0	5.5	-	-	-	-
		108A00	11.5	10.6	-	-	-	-
		109A00	14.0	12.9	-	-	-	-
		108A00,108A00	23.0	21.1	037	037	037	037
	HIGH	106A00	6.0	5.5	-	-	-	-
		108A00	11.5	10.6	-	-	-	-
		109A00	14.0	12.9	-	-	-	-
		108A00,108A00	23.0	21.1	037	037	037	037

LEGEND:

- No Single Point Kit required
- APP PWR - 208 / 230V / 460V / 575V
- C.O. - Convenience outlet
- IFM - Indoor fan motor
- NA - Not Available
- NOM PWR - 240V / 480V / 600V
- P.E. - Power exhaust
- PWRD - Powered convenience outlet
- UNPWRD - Unpowered convenience outlet

ELECTRIC HEAT – ELECTRICAL INFORMATION

Table 37 – RAX060

WITHOUT FACTORY INSTALLED NON-FUSED DISCONNECT

NOM. V-PH-Hz.	IFM TYPE	ELECTRIC HEATER PART NUMBER CRHEATERXXXXXX	NOM PWR (kW)	APP PWR (kW)	SINGLE POINT KIT PART NUMBER CRSINGLEXXXXXX			
					NO C.O. or UNPWRD C.O.		w/PWRD C.O.	
					NO P.E.	w/P.E. (pwrd fr/unit)	NO P.E.	w/P.E. (pwrd fr/unit)
208/230-1-60	DD-STD	102A00	6.5	4.9/6.0	-	-	NA	NA
		103B00	8.7	6.5/8.0	037	037	NA	NA
		102A00,102A00	13.0	9.8/11.9	040	040	NA	NA
		103B00,103B00	17.4	13.1/16.0	040	040	NA	NA
		104B00,104B00	21.0	15.8/19.3	040	040	NA	NA
	MED	102A00	6.5	4.9/6.0	-	-	NA	NA
		103B00	8.7	6.5/8.0	037	037	NA	NA
		102A00,102A00	13.0	9.8/11.9	040	040	NA	NA
		103B00,103B00	17.4	13.1/16.0	040	040	NA	NA
HIGH	104B00,104B00	21.0	15.8/19.3	040	040	NA	NA	
	102A00	6.5	4.9/6.0	-	-	NA	NA	
	103B00	8.7	6.5/8.0	037	037	NA	NA	
	102A00,102A00	13.0	9.8/11.9	040	040	NA	NA	
208/230-3-60	DD-STD	103B00,103B00	17.4	13.1/16.0	040	040	NA	NA
		104B00,104B00	21.0	15.8/19.3	040	040	NA	NA
		102A00	6.5	4.9/6.0	-	-	-	-
		104B00	10.5	7.9/9.6	-	-	-	-
		105A00	16.0	12.0/14.7	037	037	038	038
	MED	104B00,104B00	21.0	15.8/19.3	038	038	038	038
		104B00,105A00	26.5	19.9/24.3	038	038	038	038
		102A00	6.5	4.9/6.0	-	-	-	-
		104B00	10.5	7.9/9.6	-	-	-	037
HIGH	105A00	16.0	12.0/14.7	037	038	038	038	
	104B00,104B00	21.0	15.8/19.3	038	038	038	038	
	104B00,105A00	26.5	19.9/24.3	038	038	038	038	
	102A00	6.5	4.9/6.0	-	-	-	-	
	104B00	10.5	7.9/9.6	-	-	-	037	
460-3-60	DD-STD	105A00	16.0	12.0/14.7	037	038	038	038
		104B00,104B00	21.0	15.8/19.3	038	038	038	038
		104B00,105A00	26.5	19.9/24.3	038	038	038	038
		106A00	6.0	5.5	-	-	-	-
		108A00	11.5	10.6	-	-	-	-
	MED	109A00	14.0	12.9	-	-	-	-
		108A00,108A00	23.0	21.1	037	037	037	037
		108A00,109A00	25.5	23.4	037	037	037	037
		106A00	6.0	5.5	-	-	-	-
HIGH	108A00	11.5	10.6	-	-	-	-	
	109A00	14.0	12.9	-	-	-	-	
	108A00,108A00	23.0	21.1	037	037	037	037	
	108A00,109A00	25.5	23.4	037	037	037	037	
	106A00	6.0	5.5	-	-	-	-	

LEGEND:

- No Single Point Kit required
- APP PWR - 208 / 230V / 460V / 575V
- C.O. - Convenience outlet
- IFM - Indoor fan motor
- NA - Not Available
- NOM PWR - 240V / 480V / 600V
- P.E. - Power exhaust
- PWRD - Powered convenience outlet
- UNPWRD - Unpowered convenience outlet

ELECTRIC HEAT – ELECTRICAL INFORMATION

Table 38 – RAX036

WITH FACTORY INSTALLED NON-FUSED DISCONNECT

NOM. V-PH-Hz.	IFM TYPE	ELECTRIC HEATER PART NUMBER CRHEATERXXXXXX	NOM PWR (kW)	APP PWR (kW)	SINGLE POINT KIT PART NUMBER CRSINGLEXXXXXX			
					NO C.O. or UNPWRD C.O.		w/PWRD C.O.	
					NO P.E.	w/P.E. (pwrd fr/unit)	NO P.E.	w/P.E. (pwrd fr/unit)
208/230-1-60	DD-STD	101A00	4.4	3.3/4.0	037	037	NA	NA
		102A00	6.5	4.9/6.0	037	037	NA	NA
		103B00	8.7	6.5/8.0	037	037	NA	NA
		104B00	10.5	7.9/9.6	040	040	NA	NA
		102A00,102A00	13.0	9.8/11.9	040	040	NA	NA
	MED	101A00	4.4	3.3/4.0	037	037	NA	NA
		102A00	6.5	4.9/6.0	037	037	NA	NA
		103B00	8.7	6.5/8.0	037	037	NA	NA
		104B00	10.5	7.9/9.6	040	040	NA	NA
		102A00,102A00	13.0	9.8/11.9	040	040	NA	NA
	HIGH	101A00	4.4	3.3/4.0	037	037	NA	NA
		102A00	6.5	4.9/6.0	037	037	NA	NA
103B00		8.7	6.5/8.0	037	037	NA	NA	
104B00		10.5	7.9/9.6	040	040	NA	NA	
102A00,102A00		13.0	9.8/11.9	040	040	NA	NA	
208/230-3-60	DD-STD	101A00	4.4	3.3/4.0	037	037	037	037
		102A00	6.5	4.9/6.0	037	037	037	037
		103B00	8.7	6.5/8.0	037	037	037	037
		104B00	10.5	7.9/9.6	037	037	037	037
		105A00	16.0	12.0/14.7	037	037	038	038
	MED	101A00	4.4	3.3/4.0	037	037	037	037
		102A00	6.5	4.9/6.0	037	037	037	037
		103B00	8.7	6.5/8.0	037	037	037	037
		104B00	10.5	7.9/9.6	037	037	037	037
		105A00	16.0	12.0/14.7	037	037	038	038
	HIGH	101A00	4.4	3.3/4.0	037	037	037	037
		102A00	6.5	4.9/6.0	037	037	037	037
		103B00	8.7	6.5/8.0	037	037	037	037
		104B00	10.5	7.9/9.6	037	037	037	037
		105A00	16.0	12.0/14.7	037	038	038	038
460-3-60	DD-STD	106A00	6.0	5.5	-	-	-	-
		107A00	8.8	8.1	-	-	-	-
		108A00	11.5	10.6	-	-	-	-
		109A00	14.0	12.9	-	-	-	-
	MED	106A00	6.0	5.5	-	-	-	-
		107A00	8.8	8.1	-	-	-	-
		108A00	11.5	10.6	-	-	-	-
		109A00	14.0	12.9	-	-	-	-
	HIGH	106A00	6.0	5.5	-	-	-	-
		107A00	8.8	8.1	-	-	-	-
		108A00	11.5	10.6	-	-	-	-
		109A00	14.0	12.9	-	-	-	-

LEGEND:

- No Single Point Kit required
- APP PWR - 208 / 230V / 460V / 575V
- C.O. - Convenience outlet
- IFM - Indoor fan motor
- NA - Not Available
- NOM PWR - 240V / 480V / 600V
- P.E. - Power exhaust
- PWRD - Powered convenience outlet
- UNPWRD - Unpowered convenience outlet

ELECTRIC HEAT – ELECTRICAL INFORMATION

Table 39 – RAX048

WITH FACTORY INSTALLED NON-FUSED DISCONNECT

NOM. V-PH-Hz.	IFM TYPE	ELECTRIC HEATER PART NUMBER CRHEATERXXXXXX	NOM PWR (kW)	APP PWR (kW)	SINGLE POINT KIT PART NUMBER CRSINGLEXXXXXX			
					NO C.O. or UNPWRD C.O.		w/PWRD C.O.	
					NO P.E.	w/P.E. (pwrd fr/unit)	NO P.E.	w/P.E. (pwrd fr/unit)
208/230-1-60	DD-STD	101A00	4.4	3.3/4.0	037	037	NA	NA
		103B00	8.7	6.5/8.0	037	037	NA	NA
		102A00,102A00	13.0	9.8/11.9	040	040	NA	NA
		103B00,103B00	17.4	13.1/16.0	040	040	NA	NA
		104B00,104B00	21.0	15.8/19.3	040	040	NA	NA
	MED	101A00	4.4	3.3/4.0	037	037	NA	NA
		103B00	8.7	6.5/8.0	037	037	NA	NA
		102A00,102A00	13.0	9.8/11.9	040	040	NA	NA
		103B00,103B00	17.4	13.1/16.0	040	040	NA	NA
		104B00,104B00	21.0	15.8/19.3	040	040	NA	NA
	HIGH	101A00	4.4	3.3/4.0	037	037	NA	NA
		103B00	8.7	6.5/8.0	037	037	NA	NA
		102A00,102A00	13.0	9.8/11.9	040	040	NA	NA
		103B00,103B00	17.4	13.1/16.0	040	040	NA	NA
		104B00,104B00	21.0	15.8/19.3	040	040	NA	NA
208/230-3-60	DD-STD	102A00	6.5	4.9/6.0	037	037	037	037
		103B00	8.7	6.5/8.0	037	037	037	037
		105A00	16.0	12.0/14.7	037	037	038	038
		104B00,104B00	21.0	15.8/19.3	038	038	038	038
	MED	102A00	6.5	4.9/6.0	037	037	037	037
		103B00	8.7	6.5/8.0	037	037	037	037
		105A00	16.0	12.0/14.7	037	037	038	038
		104B00,104B00	21.0	15.8/19.3	038	038	038	038
	HIGH	102A00	6.5	4.9/6.0	037	037	037	037
		103B00	8.7	6.5/8.0	037	037	037	037
		105A00	16.0	12.0/14.7	037	038	038	038
		104B00,104B00	21.0	15.8/19.3	038	038	038	038
460-3-60	DD-STD	106A00	6.0	5.5	-	-	-	-
		108A00	11.5	10.6	-	-	-	-
		109A00	14.0	12.9	-	-	-	-
		108A00,108A00	23.0	21.1	037	037	037	037
	MED	106A00	6.0	5.5	-	-	-	-
		108A00	11.5	10.6	-	-	-	-
		109A00	14.0	12.9	-	-	-	-
		108A00,108A00	23.0	21.1	037	037	037	037
	HIGH	106A00	6.0	5.5	-	-	-	-
		108A00	11.5	10.6	-	-	-	-
		109A00	14.0	12.9	-	-	-	-
		108A00,108A00	23.0	21.1	037	037	037	037

LEGEND:

- No Single Point Kit required
- APP PWR - 208 / 230V / 460V / 575V
- C.O. - Convenience outlet
- IFM - Indoor fan motor
- NA - Not Available
- NOM PWR - 240V / 480V / 600V
- P.E. - Power exhaust
- PWRD - Powered convenience outlet
- UNPWRD - Unpowered convenience outlet

ELECTRIC HEAT – ELECTRICAL INFORMATION

Table 40 – RAX060

WITH FACTORY INSTALLED NON-FUSED DISCONNECT

NOM. V-PH-Hz.	IFM TYPE	ELECTRIC HEATER PART NUMBER CRHEATERXXXXXX	NOM PWR (kW)	APP PWR (kW)	SINGLE POINT KIT PART NUMBER CRSINGLEXXXXXX			
					NO C.O. or UNPWRD C.O.		w/PWRD C.O.	
					NO P.E.	w/P.E. (pwrd fr/unit)	NO P.E.	w/P.E. (pwrd fr/unit)
208/230-1-60	DD-STD	102A00	6.5	4.9/6.0	037	037	NA	NA
		103B00	8.7	6.5/8.0	037	037	NA	NA
		102A00,102A00	13.0	9.8/11.9	040	040	NA	NA
		103B00,103B00	17.4	13.1/16.0	040	040	NA	NA
		104B00,104B00	21.0	15.8/19.3	040	040	NA	NA
	MED	102A00	6.5	4.9/6.0	037	037	NA	NA
		103B00	8.7	6.5/8.0	037	037	NA	NA
		102A00,102A00	13.0	9.8/11.9	040	040	NA	NA
		103B00,103B00	17.4	13.1/16.0	040	040	NA	NA
		104B00,104B00	21.0	15.8/19.3	040	040	NA	NA
	HIGH	102A00	6.5	4.9/6.0	037	037	NA	NA
		103B00	8.7	6.5/8.0	037	037	NA	NA
102A00,102A00		13.0	9.8/11.9	040	040	NA	NA	
103B00,103B00		17.4	13.1/16.0	040	040	NA	NA	
104B00,104B00		21.0	15.8/19.3	040	040	NA	NA	
208/230-3-60	DD-STD	102A00	6.5	4.9/6.0	037	037	037	037
		104B00	10.5	7.9/9.6	037	037	037	037
		105A00	16.0	12.0/14.7	037	037	038	038
		104B00,104B00	21.0	15.8/19.3	038	038	038	038
		104B00,105A00	26.5	19.9/24.3	038	038	038	038
	MED	102A00	6.5	4.9/6.0	037	037	037	037
		104B00	10.5	7.9/9.6	037	037	037	037
		105A00	16.0	12.0/14.7	037	038	038	038
		104B00,104B00	21.0	15.8/19.3	038	038	038	038
		104B00,105A00	26.5	19.9/24.3	038	038	038	038
	HIGH	102A00	6.5	4.9/6.0	037	037	037	037
		104B00	10.5	7.9/9.6	037	037	037	037
		105A00	16.0	12.0/14.7	037	038	038	038
		104B00,104B00	21.0	15.8/19.3	038	038	038	038
		104B00,105A00	26.5	19.9/24.3	038	038	038	038
460-3-60	DD-STD	106A00	6.0	5.5	-	-	-	-
		108A00	11.5	10.6	-	-	-	-
		109A00	14.0	12.9	-	-	-	-
		108A00,108A00	23.0	21.1	037	037	037	037
		108A00,109A00	25.5	23.4	037	037	037	037
	MED	106A00	6.0	5.5	-	-	-	-
		108A00	11.5	10.6	-	-	-	-
		109A00	14.0	12.9	-	-	-	-
		108A00,108A00	23.0	21.1	037	037	037	037
		108A00,109A00	25.5	23.4	037	037	037	037
	HIGH	106A00	6.0	5.5	-	-	-	-
		108A00	11.5	10.6	-	-	-	-
		109A00	14.0	12.9	-	-	-	-
		108A00,108A00	23.0	21.1	037	037	037	037
		108A00,109A00	25.5	23.4	037	037	037	037

LEGEND:

- No Single Point Kit required
- APP PWR - 208 / 230V / 460V / 575V
- C.O. - Convenience outlet
- IFM - Indoor fan motor
- NA - Not Available
- NOM PWR - 240V / 480V / 600V
- P.E. - Power exhaust
- PWRD - Powered convenience outlet
- UNPWRD - Unpowered convenience outlet

ELECTRICAL INFORMATION

Table 41 – UNIT WIRE/FUSE OR HACR BREAKER SIZING DATA

UNIT	NO M. V-Ph-HZ	IFM TYPE	ELEC. HTR			NO C.O. or UNPWR C.O.							
			CRHEAT-ER***A00	Nom (kW)	FLA	NO P.E.				w/ P.E. (pwrd fr/unit)			
						MCA	MAX FUSE or HACR BRKR	DISC. SIZE		MCA	MAX FUSE or HACR BRKR	DISC. SIZE	
								FLA	LRA			FLA	LRA
RAX036	208/230-1-60	DD-STD	NONE	-	-	30	45	29	88	32	45	31	90
			101A	3.3/4.4	15.9/18.3	30/33	45/45	29/30	88/88	32/35	45/45	31/32	90/90
			102A	4.9/6.5	23.5/27.1	39/44	45/45	36/40	88/88	41/46	45/50	38/42	90/90
			103B	6.5/8.7	31.4/36.3	49/55	50/60	45/50	88/88	51/57	60/60	47/52	90/90
			104B	7.9/10.5	37.9/43.8	57/64	60/70	52/59	88/88	59/67	60/70	54/61	90/90
			102A+102A	9.8/13.0	46.9/54.2	68/77	70/80	62/71	88/88	71/80	80/80	65/73	90/90
		MED	NONE	-	-	27	40	26	93	29	45	28	95
			101A	3.3/4.4	15.9/18.3	27/29	40/40	26/27	93/93	29/32	45/45	28/29	95/95
			102A	4.9/6.5	23.5/27.1	36/40	40/45	33/37	93/93	38/43	45/45	35/39	95/95
			103B	6.5/8.7	31.4/36.3	46/52	50/60	42/47	93/93	48/54	50/60	44/50	95/95
			104B	7.9/10.5	37.9/43.8	54/61	60/70	49/56	93/93	56/64	60/70	51/58	95/95
			102A+102A	9.8/13.0	46.9/54.2	65/74	70/80	60/68	93/93	68/77	70/80	62/70	95/95
		HIGH	NONE	-	-	29	45	28	118	31	45	30	120
			101A	3.3/4.4	15.9/18.3	29/32	45/45	28/29	118/118	31/34	45/45	30/31	120/120
			102A	4.9/6.5	23.5/27.1	39/43	45/45	35/39	118/118	41/45	45/50	37/41	120/120
	103B		6.5/8.7	31.4/36.3	48/55	50/60	44/50	118/118	51/57	60/60	46/52	120/120	
	104B		7.9/10.5	37.9/43.8	57/64	60/70	52/58	118/118	59/66	60/70	54/61	120/120	
	102A+102A		9.8/13.0	46.9/54.2	68/77	70/80	62/70	118/118	70/79	70/80	64/73	120/120	
208/230-3-60	DD-STD	NONE	-	-	22	30	22	82	24	30	24	84	
		101A	3.3/4.4	9.2/10.6	22/23	30/30	22/22	82/82	24/25	30/30	24/24	84/84	
		102A	4.9/6.5	13.6/15.6	27/29	30/30	24/26	82/82	29/32	30/35	26/29	84/84	
		103B	6.5/8.7	18.1/20.9	32/36	35/40	29/33	82/82	35/38	35/40	32/35	84/84	
		104B	7.9/10.5	21.9/25.3	37/41	40/45	34/38	82/82	39/44	40/45	36/40	84/84	
		105A	12.0/16.0	33.4/38.5	51/58	60/60	47/53	82/82	54/60	60/60	49/55	84/84	
	MED	NONE	-	-	20/19	25/25	19/19	111	22/21	30/30	21/21	113	
		101A	3.3/4.4	9.2/10.6	20/20	25/25	19/19	111/111	22/22	30/30	21/21	113/113	
		102A	4.9/6.5	13.6/15.6	24/26	25/30	22/24	111/111	26/28	30/30	24/26	113/113	
		103B	6.5/8.7	18.1/20.9	30/33	30/35	27/30	111/111	32/35	35/35	29/32	113/113	
		104B	7.9/10.5	21.9/25.3	34/38	35/40	31/35	111/111	37/41	40/45	33/37	113/113	
	105A	12.0/16.0	33.4/38.5	49/55	50/60	44/50	111/111	51/57	60/60	47/52	113/113		
	HIGH	NONE	-	-	23/23	30/30	23/23	147	25/25	30/30	25/25	149	
		101A	3.3/4.4	9.2/10.6	23/24	30/30	23/23	147/147	25/26	30/30	25/25	149/149	
		102A	4.9/6.5	13.6/15.6	28/30	30/30	25/27	147/147	30/33	30/35	27/30	149/149	
103B		6.5/8.7	18.1/20.9	34/37	35/40	30/34	147/147	36/39	40/40	33/36	149/149		
104B		7.9/10.5	21.9/25.3	38/42	40/45	35/39	147/147	41/45	45/45	37/41	149/149		
105A	12.0/16.0	33.4/38.5	53/59	60/60	48/54	147/147	55/61	60/70	50/56	149/149			

See "Legend and Notes for Table 41 on page 43.

ELECTRICAL INFORMATION

Table 41 – Unit Wire/Fuse or HACR Breaker Sizing Data (cont)

UNIT	NO M. V-Ph-HZ	IFM TYPE	ELEC. HTR			NO C.O. or UNPWR C.O.							
			CRHEAT-ER***A00	Nom (kW)	FLA	NO P.E.				w/ P.E. (pwr fr/unit)			
						MCA	MAX FUSE or HACR BRKR	DISC. SIZE		MCA	MAX FUSE or HACR BRKR	DISC. SIZE	
								FLA	LRA			FLA	LRA
RAX036	460-3-60	DD-STD	NONE	-	-	12	15	12	43	13	15	13	44
			106A	6.0	7.2	14	15	13	43	16	20	14	44
			107A	8.8	10.6	19	20	17	43	20	20	18	44
			108A	11.5	13.8	23	25	20	43	24	25	22	44
			109A	14.0	16.8	26	30	24	43	28	30	25	44
		MED	NONE	-	-	11	15	10	57	12	15	11	58
			106A	6.0	7.2	13	15	11	57	14	15	12	58
			107A	8.8	10.6	17	20	15	57	18	20	16	58
			108A	11.5	13.8	21	25	19	57	22	25	20	58
			109A	14.0	16.8	25	25	22	57	26	30	23	58
		HIGH	NONE	-	-	12	15	12	75	13	15	13	76
			106A	6.0	7.2	15	15	13	75	16	20	14	76
			107A	8.8	10.6	19	20	17	75	20	20	18	76
			108A	11.5	13.8	23	25	21	75	24	25	22	76
			109A	14.0	16.8	27	30	24	75	28	30	25	76
575-3-60	DD-STD	NONE	-	-	10	15	10	42	12	15	12	44	
		MED	NONE	-	-	7	15	7	45	9	15	9	47
		HIGH	NONE	-	-	9	15	8	60	10	15	10	62

See "Legend and Notes for Table 41 on page 43.

ELECTRICAL INFORMATION

Table 41 – Unit Wire/Fuse or HACR Breaker Sizing Data (cont)

UNIT	NO. M. V. – Ph – HZ	IFM TYPE	ELEC. HTR			NO C.O. or UNPWR C.O.							
			CRHEATER***A00	Nom (kW)	FLA	NO P.E.				w/ P.E. (pwr fr/unit)			
						MCA	MAX FUSE or HACR BRKR	DISC. SIZE		MCA	MAX FUSE or HACR BRKR	DISC. SIZE	
								FLA	LRA			FLA	LRA
FAX048	208/230-1-60	DD-STD	NONE	-	-	37	50	35	128	39	50	37	130
			101A	3.3/4.4	15.9/18.3	37/37	50/50	35/35	128/128	39/39	50/50	37/37	130/130
			103B	6.5/8.7	31.4/36.3	49/55	50/60	45/50	128/128	51/57	60/60	47/52	130/130
			102A+102A	9.8/13.0	46.9/54.2	68/77	70/80	62/71	128/128	71/80	80/80	65/73	130/130
			103B+103B	13.1/17.4	62.8/72.5	88/100	90/100	81/92	128/128	91/103	100/110	83/94	130/130
			104B+104B	15.8/21.0	75.8/87.5	104/119	110/125	96/109	128/128	107/121	110/125	98/111	130/130
		MED	NONE	-	-	34	50	32	133	36	50	35	135
			101A	3.3/4.4	15.9/18.3	34/34	50/50	32/32	133/133	36/36	50/50	35/35	135/135
			103B	6.5/8.7	31.4/36.3	46/52	50/60	42/47	133/133	48/54	50/60	44/50	135/135
			102A+102A	9.8/13.0	46.9/54.2	65/74	70/80	60/68	133/133	68/77	70/80	62/70	135/135
			103B+103B	13.1/17.4	62.8/72.5	85/97	90/100	78/89	133/133	87/100	90/100	80/91	135/135
			104B+104B	15.8/21.0	75.8/87.5	101/116	110/125	93/106	133/133	104/118	110/125	95/108	135/135
		HIGH	NONE	-	-	36	50	35	158	38	50	37	160
			101A	3.3/4.4	15.9/18.3	36/36	50/50	35/35	158/158	38/38	50/50	37/37	160/160
			103B	6.5/8.7	31.4/36.3	48/55	50/60	44/50	158/158	51/57	60/60	46/52	160/160
			102A+102A	9.8/13.0	46.9/54.2	68/77	70/80	62/70	158/158	70/79	70/80	64/73	160/160
			103B+103B	13.1/17.4	62.8/72.5	88/100	90/100	80/91	158/158	90/102	90/110	82/94	160/160
			104B+104B	15.8/21.0	75.8/87.5	104/119	110/125	95/109	158/158	106/121	110/125	97/111	160/160
FAX048	208/230-3-60	DD-STD	NONE	-	-	26	30	26	94	28	40	28	96
			102A	4.9/6.5	13.6/15.6	27/29	30/30	26/26	94/94	29/32	40/40	28/29	96/96
			103B	6.5/8.7	18.1/20.9	32/36	35/40	29/33	94/94	35/38	40/40	32/35	96/96
			105A	12.0/16.0	33.4/38.5	51/58	60/60	47/53	94/94	54/60	60/60	49/55	96/96
			104B+104B	15.8/21.0	43.8/50.5	64/73	70/80	59/67	94/94	67/75	70/80	61/69	96/96
		MED	NONE	-	-	24/24	30/30	23/23	123	26/26	30/30	26/25	125
			102A	4.9/6.5	13.6/15.6	24/26	30/30	23/24	123/123	26/28	30/30	26/26	125/125
			103B	6.5/8.7	18.1/20.9	30/33	30/35	27/30	123/123	32/35	35/35	29/32	125/125
			105A	12.0/16.0	33.4/38.5	49/55	50/60	44/50	123/123	51/57	60/60	47/52	125/125
			104B+104B	15.8/21.0	43.8/50.5	62/70	70/70	56/64	123/123	64/72	70/80	59/66	125/125
		HIGH	NONE	-	-	27/27	40/40	27/27	159	29/29	40/40	29/29	161
			102A	4.9/6.5	13.6/15.6	28/30	40/40	27/27	159/159	30/33	40/40	29/30	161/161
			103B	6.5/8.7	18.1/20.9	34/37	40/40	30/34	159/159	36/39	40/40	33/36	161/161
			105A	12.0/16.0	33.4/38.5	53/59	60/60	48/54	159/159	55/61	60/70	50/56	161/161
			104B+104B	15.8/21.0	43.8/50.5	66/74	70/80	60/68	159/159	68/76	70/80	62/70	161/161

See "Legend and Notes for Table 41 on page 43.

ELECTRICAL INFORMATION

Table 41 – Unit Wire/Fuse or HACR Breaker Sizing Data (cont)

UNIT	NO M. V – Ph – HZ	IFM TYPE	ELEC. HTR			NO C.O. or UNPWR C.O.							
			CRHEAT-ER***A00	Nom (kW)	FLA	NO P.E.				w/ P.E. (pwrd fr/unit)			
						MCA	MAX FUSE or HACR BRKR	DISC. SIZE		MCA	MAX FUSE or HACR BRKR	DISC. SIZE	
								FLA	LRA			FLA	LRA
RAX048	460-3-60	DD-STD	NONE	-	-	13	15	13	47	14	20	14	48
			106A	6.0	7.2	14	15	13	47	16	20	14	48
			108A	11.5	13.8	23	25	20	47	24	25	22	48
			109A	14.0	16.8	26	30	24	47	28	30	25	48
			108A+108A	23.0	27.7	40	40	36	47	41	45	38	48
		MED	NONE	-	-	12	15	11	61	13	15	12	62
	106A	6.0	7.2	13	15	11	61	14	15	12	62		
	108A	11.5	13.8	21	25	19	61	22	25	20	62		
	109A	14.0	16.8	25	25	22	61	26	30	23	62		
	108A+108A	23.0	27.7	38	40	35	61	39	40	36	62		
	HIGH	NONE	-	-	13	15	13	79	14	20	14	80	
	106A	6.0	7.2	15	15	13	79	16	20	14	80		
108A	11.5	13.8	23	25	21	79	24	25	22	80			
109A	14.0	16.8	27	30	24	79	28	30	25	80			
108A+108A	23.0	27.7	40	40	37	79	42	45	38	80			
575-3-60	DD-STD	NONE	-	-	11	15	11	39	13	15	13	41	
	MED	NONE	-	-	9	15	8	42	11	15	10	44	
	HIGH	NONE	-	-	10	15	9	57	12	15	12	59	

See "Legend and Notes for Table 41 on page 43.

ELECTRICAL INFORMATION

Table 41 – Unit Wire/Fuse or HACR Breaker Sizing Data (cont)

UNIT	NO M. V – Ph – HZ	IFM TYPE	ELEC. HTR			NO C.O. or UNPWR C.O.							
			CRHEAT-ER***A00	Nom (kW)	FLA	NO P.E.				w/ P.E. (pwrd fr/unit)			
						MCA	MAX FUSE or HACR BRKR	DISC. SIZE		MCA	MAX FUSE or HACR BRKR	DISC. SIZE	
								FLA	LRA			FLA	LRA
RAX060	208/230-1-60	DD-STD	NONE	–	–	41	60	39	144	42	60	41	146
			102A	4.9/6.5	23.5/27.1	41/44	60/60	39/40	144/144	42/46	60/60	41/42	146/146
			103B	6.5/8.7	31.4/36.3	49/55	60/60	45/50	144/144	51/57	60/60	47/52	146/146
			102A+102A	9.8/13.0	46.9/54.2	68/77	70/80	62/71	144/144	71/80	80/80	65/73	146/146
			103B+103B	13.1/17.4	62.8/72.5	88/100	90/100	81/92	144/144	91/103	100/110	83/94	146/146
		104B+104B	15.8/21.0	75.8/87.5	104/119	110/125	96/109	144/144	107/121	110/125	98/111	146/146	
		MED	NONE	–	–	38	60	36	149	40	60	38	151
			102A	4.9/6.5	23.5/27.1	38/40	60/60	36/37	149/149	40/43	60/60	38/39	151/151
			103B	6.5/8.7	31.4/36.3	46/52	60/60	42/47	149/149	48/54	60/60	44/50	151/151
	102A+102A		9.8/13.0	46.9/54.2	65/74	70/80	60/68	149/149	68/77	70/80	62/70	151/151	
	HIGH	103B+103B	13.1/17.4	62.8/72.5	85/97	90/100	78/89	149/149	87/100	90/100	80/91	151/151	
		104B+104B	15.8/21.0	75.8/87.5	101/116	110/125	93/106	149/149	104/118	110/125	95/108	151/151	
		NONE	–	–	40	60	38	174	42	60	41	176	
		102A	4.9/6.5	23.5/27.1	40/43	60/60	38/39	174/174	42/45	60/60	41/41	176/176	
		103B	6.5/8.7	31.4/36.3	48/55	60/60	44/50	174/174	51/57	60/60	46/52	176/176	
	DD-STD	102A+102A	9.8/13.0	46.9/54.2	68/77	70/80	62/70	174/174	70/79	70/80	64/73	176/176	
		103B+103B	13.1/17.4	62.8/72.5	88/100	90/100	80/91	174/174	90/102	90/110	82/94	176/176	
		104B+104B	15.8/21.0	75.8/87.5	104/119	110/125	95/109	174/174	106/121	110/125	97/111	176/176	
NONE		–	–	29	40	28	120	31	45	31	122		
102A		4.9/6.5	13.6/15.6	29/29	40/40	28/28	120/120	31/32	45/45	31/31	122/122		
MED	104B	7.9/10.5	21.9/25.3	37/41	40/45	34/38	120/120	39/44	45/45	36/40	122/122		
	105A	12.0/16.0	33.4/38.5	51/58	60/60	47/53	120/120	54/60	60/60	49/55	122/122		
	104B+104B	15.8/21.0	43.8/50.5	64/73	70/80	59/67	120/120	67/75	70/80	61/69	122/122		
	104B+105A	19.9/26.5	55.2/63.8	79/89	80/90	72/82	120/120	81/92	90/100	74/84	122/122		
	NONE	–	–	30/30	45/45	30/29	185	32/32	45/45	32/32	187		
HIGH	102A	4.9/6.5	13.6/15.6	30/30	45/45	30/29	185/185	32/33	45/45	32/32	187/187		
	104B	7.9/10.5	21.9/25.3	38/42	45/45	35/39	185/185	41/45	45/45	37/41	187/187		
	105A	12.0/16.0	33.4/38.5	53/59	60/60	48/54	185/185	55/61	60/70	50/56	187/187		
	104B+104B	15.8/21.0	43.8/50.5	66/74	70/80	60/68	185/185	68/76	70/80	62/70	187/187		
	104B+105A	19.9/26.5	55.2/63.8	80/91	80/100	73/83	185/185	82/93	90/100	75/85	187/187		

See "Legend and Notes for Table 41 on page 43.

ELECTRICAL INFORMATION

Table 41 – Unit Wire/Fuse or HACR Breaker Sizing Data (cont)

UNIT	NO M. V. – Ph – HZ	IFM TYPE	ELEC. HTR			NO C.O. or UNPWR C.O.							
			CRHEAT-ER***A00	Nom (kW)	FLA	NO P.E.				w/ P.E. (pwr fr/unit)			
						MCA	MAX FUSE or HACR BRKR	DISC. SIZE		MCA	MAX FUSE or HACR BRKR	DISC. SIZE	
								FLA	LRA			FLA	LRA
RAX060	460-3-60	DD-STD	NONE	-	-	14	20	14	58	15	20	15	59
			106A	6.0	7.2	14	20	14	58	16	20	15	59
			108A	11.5	13.8	23	25	20	58	24	25	22	59
			109A	14.0	16.8	26	30	24	58	28	30	25	59
			108A+108A	23.0	27.7	40	40	36	58	41	45	38	59
			108A+109A	25.5	30.7	44	45	40	58	45	45	41	59
		MED	NONE	-	-	14	20	14	90	15	20	15	91
			106A	6.0	7.2	15	20	14	90	16	20	15	91
			108A	11.5	13.8	23	25	21	90	24	25	22	91
			109A	14.0	16.8	27	30	24	90	28	30	25	91
			108A+108A	23.0	27.7	40	40	37	90	42	45	38	91
			108A+109A	25.5	30.7	44	45	40	90	45	45	41	91
		HIGH	NONE	-	-	14	20	14	90	15	20	15	91
			106A	6.0	7.2	15	20	14	90	16	20	15	91
			108A	11.5	13.8	23	25	21	90	24	25	22	91
			109A	14.0	16.8	27	30	24	90	28	30	25	91
			108A+108A	23.0	27.7	40	40	37	90	42	45	38	91
			108A+109A	25.5	30.7	44	45	40	90	45	45	41	91
575-3-60		DD-STD	NONE	-	-	12	15	12	46	14	15	14	48
		MED	NONE	-	-	11	15	10	64	12	15	12	66
		HIGH	NONE	-	-	11	15	10	64	12	15	12	66

See "Legend and Notes for Table 41 on page 43.

Legend and Notes for Table 41

LEGEND:

- BRKR - Circuit breaker
- CO - Convenient outlet
- DD - Direct drive (indoor fan motor)
- DISC - Disconnect
- FLA - Full load amps
- IFM - Indoor fan motor
- LRA - Locked rotor amps
- MCA - Minimum circuit amps
- MOCB - MAX FUSE or HACR Breaker
- PE - Power exhaust
- UNPWR CO - Unpowered convenient outlet

NOTES:

1. In compliance with NEC requirements for multimotor and combination load equipment (refer to NEC Articles 430 and 440), the overcurrent protective device for the unit shall be fuse or HACR breaker. Canadian units may be fuse or circuit breaker.
2. **Unbalanced 3-Phase Supply Voltage**
Never operate a motor where a phase imbalance in supply voltage is greater than 2%. Use the following formula to determine the percentage of voltage imbalance.

$$\% \text{ Voltage Imbalance} = 100 \times \frac{\text{max voltage deviation from average voltage}}{\text{average voltage}}$$

Example: Supply voltage is 230-3-60



- AB = 224 v
- BC = 231 v
- AC = 226 v

$$\begin{aligned} \text{Average Voltage} &= \frac{(224 + 231 + 226)}{3} = \frac{681}{3} \\ &= 227 \end{aligned}$$

Determine maximum deviation from average voltage.

(AB) 227 - 224 = 3 v

(BC) 231 - 227 = 4 v

(AC) 227 - 226 = 1 v

Maximum deviation is 4 v.

Determine percent of voltage imbalance.

$$\begin{aligned} \% \text{ Voltage Imbalance} &= 100 \times \frac{4}{227} \\ &= 1.76\% \end{aligned}$$

This amount of phase imbalance is satisfactory as it is below the maximum allowable 2%.

IMPORTANT: If the supply voltage phase imbalance is more than 2%, contact your local electric utility company immediately.

SEQUENCE OF OPERATION

General

The sequence below describes the sequence of operation for an electromechanical unit with and without a factory installed EconoMi\$er™ IV and X (called “economizer” in this sequence). For information regarding a direct digital controller, see the start-up, operations, and troubleshooting manual for the applicable controller.

Electromechanical units with no economizer

Cooling (Single speed indoor fan motor) —

When the thermostat calls for cooling, terminals G and Y1 are energized. As a result, the indoor fan contactor (IFC) and the compressor contactor (C1) are energized, causing the indoor fan motor (IFM), compressor #1, and outdoor fan to start. If the unit has 2 stages of cooling, the thermostat will additionally energize Y2. The Y2 signal will energize compressor contactor #2 (C2), causing compressor #2 to start. Regardless of the number of stages, the outdoor fan motor runs continuously while unit is cooling.

Heating

NOTE: The RAX is sold as cooling only. If electric heaters are required, use only factory-approved electric heaters. They will operate as described below.

Units have either 1 or 2 stages of electric heat. When the thermostat calls for heating, power is applied to the W1 terminal at the unit. The unit control will energize the indoor fan contactor and the first stage of electric heat. On units with 2-stage heating, when additional heating is required, the second stage of

electric heat (if equipped) will be energized when power is applied at the W2 terminal on the unit.

Electromechanical units with an economizer

Cooling —

When free cooling is not available, the compressors will be controlled by the zone thermostat. When free cooling is available, the outdoor air damper is modulated by the EconoMi\$er IV and X control to provide a 50°F (10°C) to 55°F (13°C) mixed air temperature into the zone. As the mixed air temperature fluctuates above 55°F (13°C) or below 50°F (10°C) dampers will be modulated (open or close) to bring the mixed air temperature back within control. If mechanical cooling is utilized with free cooling, the outdoor air damper will maintain its current position at the time the compressor is started. If the increase in cooling capacity causes the mixed air temperature to drop below 45°F (9°C), then the outdoor air damper position will be decreased to the minimum position. If the mixed air temperature continues to fall, the outdoor air damper will close. Control returns to normal once the mixed air temperature rises above 48°F (9°C). The power exhaust fans will be energized and de-energized, if installed, as the outdoor air damper opens and closes.

If field-installed accessory CO₂ sensors are connected to the EconoMi\$er IV and X control, a demand controlled ventilation strategy will begin to operate. As the CO₂ level in the zone increases above the CO₂ setpoint, the minimum position of the damper will be increased proportionally. As the CO₂ level decreases because of the increase in fresh air,

the outdoor air damper will be proportionally closed. For EconoMi\$er IV and X operation, there must be a thermostat call for the fan (G). If the unit is occupied and the fan is on, the damper will operate at minimum position. Otherwise, the damper will be closed.

When the EconoMi\$er IV and X control is in the occupied mode and a call for cooling exists (Y1 on the thermostat), the control will first check for indoor fan operation. If the fan is not on, then cooling will not be activated. If the fan is on, then the control will open the EconoMi\$er IV and X damper to the minimum position.

On the initial power to the EconoMi\$er IV and X control, it will take the damper up to 2 1/2 minutes before it begins to position itself. After the initial power-up, further changes in damper position can take up to 30 seconds to initiate. Damper movement from full closed to full open (or vice versa) will take between 1 1/2 and 2 1/2 minutes. If free cooling can be used as determined from the appropriate changeover command (switch, dry bulb, enthalpy curve, differential dry bulb, or differential enthalpy), then the control will modulate the dampers open to maintain the mixed air temperature setpoint at 50°F (10°C) to 55°F (13°C). If there is a further demand for cooling (cooling second stage – Y2 is energized), then the control will bring on compressor stage 1 to maintain the mixed air temperature setpoint. The EconoMi\$er IV and X damper will be open at maximum position. EconoMi\$er IV and X operation is limited to a single compressor.

Heating

The sequence of operation for the heating is the same as an electromechanical unit with no economizer. The only difference is how the economizer acts. The economizer will stay at the Economizer Minimum Position while the evaporator fan is operating. The outdoor air damper is closed when the indoor fan is not operating.

Optional Hot Gas ReHeat Dehumidification System

Units with the factory equipped Hot Gas ReHeat option are capable of providing multiple modes of improved dehumidification as a variation of the normal cooling cycle. The Hot Gas ReHeat option includes additional valves in the liquid line and discharge line of each refrigerant circuit, a small reheat condenser coil downstream of the evaporator, and Motormaster variable-speed control of some or all outdoor fans. Operation of the revised refrigerant circuit for each mode is described below.

The Hot Gas ReHeat system provides three sub-modes of operation: Cool, Reheat1, and Reheat2.

Cool mode – provides a normal ratio of Sensible and Latent Cooling effect from the evaporator coil.

Reheat1 – provides increased Latent Cooling while slightly reducing the Sensible Cooling effect.

Reheat2 – provides normal Latent Cooling but with null or minimum Sensible Cooling effect delivered to the space.

The Reheat1 and Reheat2 modes are available when the unit is not in a Heating mode and when the Low Ambient Lockout switch is closed.

The following diagrams depict piping for Single Stage cooling units.

SEQUENCE OF OPERATION (cont.)

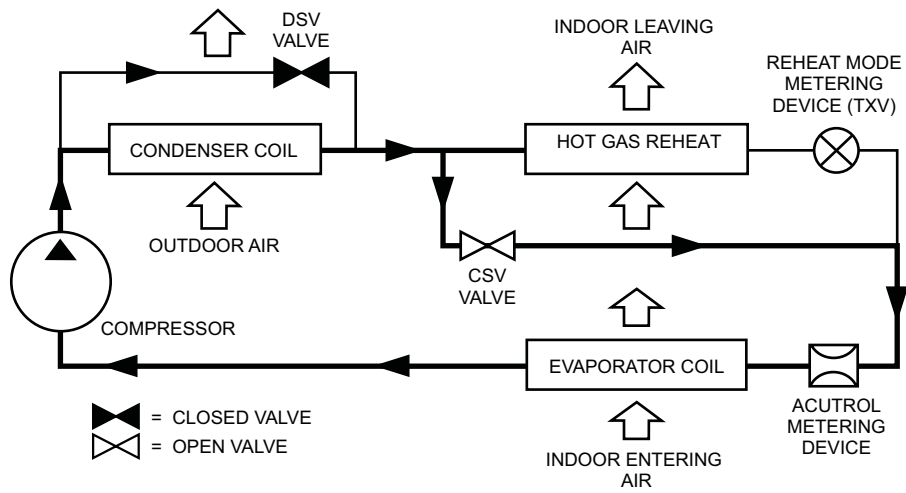

Fig. 5 – Normal Cooling Mode – Hot Gas ReHeat System with Single Stage Cooling

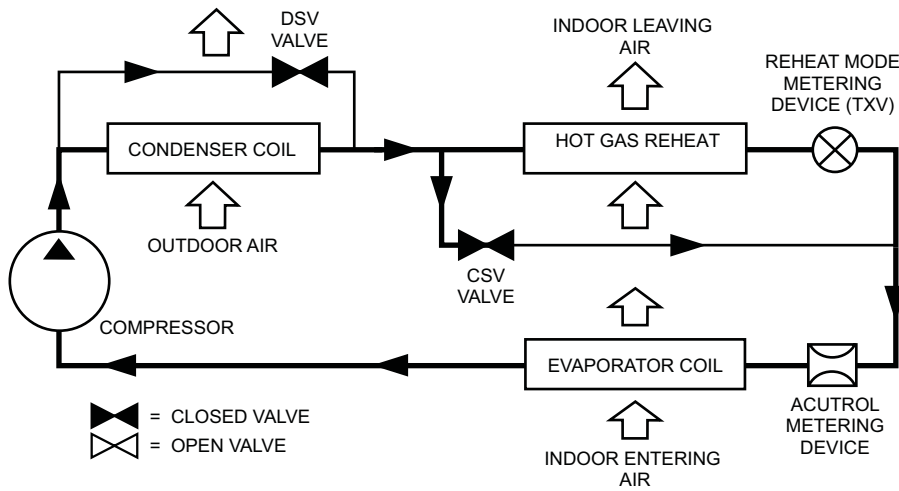

Fig. 6 – Subcooling Mode (Reheat 1) – Hot Gas ReHeat System with Single Stage Cooling

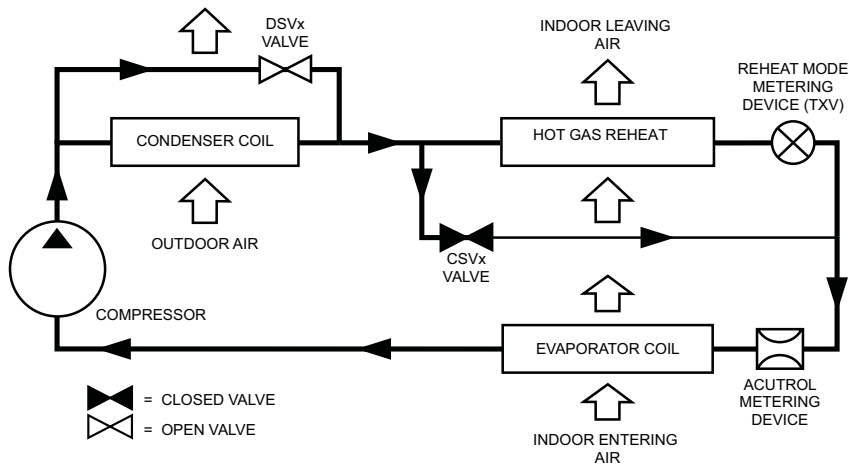

Fig. 7 – Hot Gas Reheat Mode (Reheat 2) – Hot Gas ReHeat System with Single Stage Cooling

GUIDE SPECIFICATIONS – RAX036–060

Cooling Only/Electric Heat Packaged Rooftop

HVAC Guide Specifications

Size Range: 3 to 5 Nominal
Tons

Section	Description
---------	-------------

23 06 80	Schedules for Decentralized HVAC Equipment
-----------------	---

23 06 80.13	Decentralized Unitary HVAC Equipment Schedule
-------------	---

23 06 80.13.A.	Rooftop unit schedule
----------------	-----------------------

1. Schedule is per the project specification requirements.

23 07 16	HVAC Equipment Insulation
-----------------	----------------------------------

23 07 16.13	Decentralized, Rooftop Units:
-------------	-------------------------------

23 07 16.13.A.	Evaporator fan compartment:
----------------	-----------------------------

1. Interior cabinet surfaces shall be insulated with a minimum 1/2-in. thick, minimum 1 1/2 lb density, flexible fiberglass insulation bonded with a phenolic binder, neoprene coated on the air side.
2. Insulation and adhesive shall meet NFPA 90A requirements for flame spread and smoke generation.
3. Insulation shall meet the requirements for microbial resistance per ASTM C-1071. ASTM C1071 includes Fungi Resistance – ASTM C1338, ASTM G-21 and Bacteria Resistance – ASTM G-22.
 - a. Fungi Resistance – ASTM C1338, ASTM G-21 – The insulation shall be observed as having no fungal growth greater than that of a comparative control.
 - b. Bacteria Resistance – ASTM G-22 – The insulation shall be observed as having no bacterial growth greater than that of a comparative control.
 - c. Insulation shall meet the erosion requirements of UL 181.

23 07 16.13.B.	Electric heat compartment:
----------------	----------------------------

1. Aluminum foil-faced fiberglass insulation shall be used.
2. Insulation and adhesive shall meet NFPA 90A requirements for flame spread and smoke generation.

23 09 13	Instrumentation and Control Devices for HVAC
-----------------	---

23 09 13.23	Sensors and Transmitters
-------------	--------------------------

23 09 13.23.A.	Thermostats
----------------	-------------

1. Thermostat must
 - a. energize both “W” and “G” when calling for heat.
 - b. have capability to energize 1 stage of cooling, and 2 different stages of heating.
 - c. include capability for occupancy scheduling.

23 09 33	Electric and Electronic Control System for HVAC
-----------------	--

23 09 33.13	Decentralized, Rooftop Units:
-------------	-------------------------------

23 09 33.13.A.	General:
----------------	----------

1. Shall be complete with self-contained low-voltage control circuit protected by a resettable circuit breaker on the 24-v transformer side. Transformer shall have 75VA capability.
2. Shall utilize color-coded wiring.
3. Shall include a central control terminal board to conveniently and safely provide connection points for vital control functions such as: smoke detectors, phase monitor, economizer, thermostat, DDC control options, and low and high pressure switches.
4. Unit shall include a minimum of one 8-pin screw terminal connection board for connection of control wiring.

23 09 33.23.B.	Safeties:
----------------	-----------

1. Compressor over-temperature, over current.
2. Low pressure switch.
 - a. Low pressure switch shall use different color wire than the high pressure switch. The purpose is to assist the installer and service technician to correctly wire and or troubleshoot the rooftop unit.
3. High pressure switch.

- a. High pressure switch shall use different color wire than the low pressure switch. The purpose is to assist the installer and service technician to correctly wire and or troubleshoot the rooftop unit.
4. Automatic reset, motor thermal overload protector.

23 09 93 Sequence of Operations for HVAC Controls

- 23 09 93.13 Decentralized, Rooftop Units:
- 23 09 93.13 INSERT SEQUENCE OF OPERATION

23 40 13 Panel Air Filters

- 23 40 13.13 Decentralized, Rooftop Units:
- 23 40 13.13.A. Standard filter section
 1. Shall consist of factory-installed, low velocity, throwaway 2-in. thick fiberglass filters of commercially available sizes.
 2. Unit shall use only one filter size. Multiple sizes are not acceptable.
 3. Filters shall be accessible through an access panel with “no-tool” removal as described in the unit cabinet section of this specification (23 81 19.13.G).

23 81 19 Self-Contained Air Conditioners

- 23 81 19.13 Small-Capacity Self-Contained Air Conditioners (RAX036-060)
- 23 81 19.13.A. General

1. Outdoor, rooftop mounted, electrically controlled, heating and cooling unit utilizing a(n) hermetic scroll compressor(s) for cooling duty and gas combustion for heating duty.
2. Factory assembled, single-piece heating and cooling rooftop unit. Contained within the unit enclosure shall be all factory wiring, piping, controls, and special features required prior to field start-up.
3. Unit shall use R-410A refrigerant.
4. Unit shall be installed in accordance with the manufacturer’s instructions.
5. Unit must be selected and installed in compliance with local, state, and federal codes.

23 81 19.13.B. Quality Assurance

1. Unit meets ASHRAE 90.1 minimum efficiency requirements.
2. Unit shall be rated in accordance with AHRI Standards 210/240.
3. Unit shall be designed to conform to ASHRAE 15.
4. Unit shall be UL-tested and certified in accordance with ANSI Z21.47 Standards and UL-listed and certified under Canadian standards as a total package for safety requirements.
5. Insulation and adhesive shall meet NFPA 90A requirements for flame spread and smoke generation.
6. Unit casing shall be capable of withstanding 500-hour salt spray exposure per ASTM B117 (scribed specimen).
7. Unit shall be designed in accordance with ISO 9001:2000, and shall be manufactured in a facility registered by ISO 9001:2000.
8. Roof curb shall be designed to conform to NRCA Standards.
9. Unit shall be subjected to a completely automated run test on the assembly line. The data for each unit will be stored at the factory, and must be available upon request.
10. Unit shall be designed in accordance with UL Standard 1995, including tested to withstand rain.
11. Unit shall be constructed to prevent intrusion of snow and tested to prevent snow intrusion into the control box up to 40 mph.
12. Unit shake tested to assurance level 1, ASTM D4169 to ensure shipping reliability.

23 81 19.13.C. Delivery, Storage, and Handling

1. Unit shall be stored and handled per manufacturer’s recommendations.
2. Lifted by crane requires either shipping top panel or spreader bars.
3. Unit shall only be stored or positioned in the upright position.

23 81 19.13.D. Project Conditions

1. As specified in the contract.

23 81 19.13.E. Operating Characteristics

1. Unit shall be capable of starting and running at 115°F (46°C) ambient outdoor temperature, meeting maximum load criteria of AHRI Standard 210/240 at ± 10% voltage.
2. Compressor with standard controls shall be capable of operation down to 40°F (4°C), ambient outdoor temperatures. Accessory winter start kit is necessary if mechanically cooling at ambient temperatures down to 25°F (-4°C).

3. Unit shall discharge supply air vertically or horizontally as shown on contract drawings.
4. Unit shall be factory configured for vertical supply & return configurations.
5. Unit shall be field convertible from vertical to horizontal airflow on all models. No special kit required.
6. Unit shall be capable of mixed operation: vertical supply with horizontal return or horizontal supply with vertical return.

23 81 19.13.F. Electrical Requirements

1. Main power supply voltage, phase, and frequency must match those required by the manufacturer.

23 81 19.13.G. Unit Cabinet

1. Unit cabinet shall be constructed of galvanized steel, and shall be bonderized and coated with a pre-painted baked enamel finish on all externally exposed surfaces.
2. Unit cabinet exterior paint shall be: film thickness, (dry) 0.003 inches minimum, gloss (per ASTM D523, 60°F): 60, Hardness: H-2H Pencil hardness.
3. Evaporator fan compartment interior cabinet insulation shall conform to AHRI Standards 210/240 minimum exterior sweat criteria. Interior surfaces shall be insulated with a minimum 1/2-in. thick, 1 lb density, flexible fiberglass insulation, neoprene coated on the air side. Aluminum foil-faced fiberglass insulation shall be used in the heat compartment.
4. Base of unit shall have a minimum of four locations for thru-the-base gas and electrical connections (factory installed or field installed), standard.
5. Base Rail
 - a. Unit shall have base rails on a minimum of 2 sides.
 - b. Holes shall be provided in the base rails for rigging shackles to facilitate maneuvering and overhead rigging.
 - c. Holes shall be provided in the base rail for moving the rooftop by fork truck.
 - d. Base rail shall be a minimum of 16 gauge thickness.
6. Condensate pan and connections:
 - a. Shall be a sloped condensate drain pan made of a non-corrosive material.
 - b. Shall comply with ASHRAE Standard 62.
 - c. Shall use a 3/4" -14 NPT drain connection, possible either through the bottom or end of the drain pan. Connection shall be made per manufacturer's recommendations.
7. Top panel:
 - a. Shall be a single piece top panel on all sizes.
8. Electrical Connections
 - a. All unit power wiring shall enter unit cabinet at a single, factory-prepared, knockout location.
 - b. Thru-the-base capability
 - (1.) Standard unit shall have a thru-the-base electrical location(s) using a raised, embossed portion of the unit basepan.
 - (2.) Optional, factory-approved, water-tight connection method must be used for thru-the-base electrical connections.
 - (3.) No basepan penetration, other than those authorized by the manufacturer, is permitted.
9. Component access panels (standard)
 - a. Cabinet panels shall be easily removable for servicing.
 - b. Unit shall have one factory installed, tool-less, removable, filter access panel.
 - c. Panels covering control box, indoor fan, indoor fan motor, gas components (where applicable), and compressors shall have molded composite handles.
 - d. Handles shall be UV modified, composite. permanently attached, and recessed into the panel.
 - e. Screws on the vertical portion of all removable access panel shall engage into heat resistant, molded composite collars.
 - f. Collars shall be removable and easily replaceable using manufacturer recommended parts.

23 81 19.13.H. Coils

1. Standard Aluminum fin - Copper Tube Coils:
 - a. Standard evaporator and condenser coils shall have aluminum lanced plate fins mechanically bonded to seamless internally grooved copper tubes with all joints brazed.
 - b. Evaporator coils shall be leak tested to 150 psig, pressure tested to 450 psig, and qualified to UL 1995 burst test at 1775 psig.

- c. Condenser coils shall be leak tested to 150 psig, pressure tested to 650 psig, and qualified to UL 1995 burst test at 1980 psig.
- 2. Optional Pre-coated aluminum-fin condenser coils (3 Phase Models Only):
 - a. Shall have a durable epoxy-phenolic coating to provide protection in mildly corrosive coastal environments.
 - b. Coating shall be applied to the aluminum fin stock prior to the fin stamping process to create an inert barrier between the aluminum fin and copper tube.
 - c. Epoxy-phenolic barrier shall minimize galvanic action between dissimilar metals.
- 3. Optional Copper-fin evaporator and condenser coils (3 Phase Models Only):
 - a. Shall be constructed of copper fins mechanically bonded to copper tubes and copper tube sheets.
 - b. Galvanized steel tube sheets shall not be acceptable.
 - c. A polymer strip shall prevent coil assembly from contacting the sheet metal coil pan to minimize potential for galvanic corrosion between coil and pan.
- 4. Optional E-coated aluminum-fin evaporator and condenser coils (3 Phase Models Only):
 - a. Shall have a flexible epoxy polymer coating uniformly applied to all coil surface areas without material bridging between fins.
 - b. Coating process shall ensure complete coil encapsulation of tubes, fins and headers.
 - c. Color shall be high gloss black with gloss per ASTM D523-89.
 - d. Uniform dry film thickness from 0.8 to 1.2 mil on all surface areas including fin edges.
 - e. Superior hardness characteristics of 2H per ASTM D3363-92A and cross-hatch adhesion of 4B-5B per ASTM D3359-93.
 - f. Impact resistance shall be up to 160 in.-lb (ASTM D2794-93).
 - g. Humidity and water immersion resistance shall be up to minimum 1000 and 250 hours respectively (ASTM D2247-92 and ASTM D870-92).
 - h. Corrosion durability shall be confirmed through testing to be no less than 1000 hours salt spray per ASTM B117-90.
- 5. Standard All Aluminum Novation Coils:

23 81 19.13.I. Refrigerant Components

- 1. Refrigerant circuit shall include the following control, safety, and maintenance features:
 - a. Fixed orifice metering system shall prevent mal-distribution of two-phase refrigerant by including multiple fixed orifice devices in each refrigeration circuit. Each orifice is to be optimized to the coil circuit it serves.
 - b. Refrigerant filter drier.
 - c. Service gauge connections on suction and discharge lines.
 - d. Pressure gauge access through a specially designed access port in the top panel of the unit.
- 2. There shall be gauge line access port in the skin of the rooftop, covered by a black, removable plug.
 - a. The plug shall be easy to remove and replace.
 - b. When the plug is removed, the gauge access port shall enable maintenance personnel to route their pressure gauge lines.
 - c. This gauge access port shall facilitate correct and accurate condenser pressure readings by enabling the reading with the compressor access panel on.
 - d. The plug shall be made of a leak proof, UV-resistant, composite material.
- 3. Compressors
 - a. Unit shall use one fully hermetic, scroll compressor for each independent refrigeration circuit.
 - b. Compressor motors shall be cooled by refrigerant gas passing through motor windings.
 - c. Compressors shall be internally protected from high discharge temperature conditions.
 - d. Compressors shall be protected from an over-temperature and over-ampereage conditions by an internal, motor overload device.
 - e. Compressor shall be factory mounted on rubber grommets.
 - f. Compressor motors shall have internal line break thermal, current overload and high pressure differential protection.
 - g. Crankcase heaters shall not be required for normal operating range, unless provided by compressor manufacturer due to refrigerant charge limits.

23 81 19.13.J. Filter Section

- 1. Filters access is specified in the unit cabinet section of this specification.

2. Filters shall be held in place by a pivoting filter tray, facilitating easy removal and installation.
3. Shall consist of factory-installed, low velocity, throw-away 2-in. thick fiberglass filters.
4. Filters shall be standard, commercially available sizes.
5. Only one size filter per unit is allowed.

23 81 19.13.K. Evaporator Fan and Motor

1. Evaporator fan motor:
 - a. Shall have permanently lubricated bearings.
 - b. Shall have inherent automatic-reset thermal overload protection or circuit breaker.
 - c. Shall have a maximum continuous bhp rating for continuous duty operation; no safety factors above that rating shall be required.
2. Direct Drive ECM X13 – Evaporator Fan Standard:
 - a. Multi-speed motor with easy quick adjustment settings.
 - b. Blower fan shall be double-inlet type with forward-curved blades.
 - c. Shall be constructed from steel with a corrosion resistant finish and dynamically balanced.
3. Belt-driven Evaporator Fan Optional:
 - a. Belt drive shall include an adjustable pitch motor pulley.
 - b. Shall use sealed, permanently lubricated ball-bearing type.
 - c. Blower fan shall be double-inlet type with forward-curved blades.
 - d. Shall be constructed from steel with a corrosion resistant finish and dynamically balanced.

23 81 19.13.L. Condenser Fans and Motors

1. Condenser fan motors:
 - a. Shall be a totally enclosed motor.
 - b. Shall use permanently lubricated bearings.
 - c. Shall have inherent thermal overload protection with an automatic reset feature.
 - d. Shall use a shaft-down design on all sizes.
2. Condenser Fans:
 - a. Shall be a direct-driven propeller type fan.
 - b. Shall have galvalum blades riveted to corrosion-resistant steel spiders and shall be dynamically balanced.

23 81 19.13.M. Special Features, Options and Accessories

1. Integrated EconoMi\$er IV and EconoMi\$er X standard leak rate models. (Factory installed on 3 phase models only. Field installed on all 3 and 1 phase models)
 - a. Integrated, gear driven opposing modulating blade design type capable of simultaneous economizer and compressor operation.
 - b. Independent modules for vertical or horizontal return configuration shall be available. Vertical return modules shall be available as a factory installed option.
 - c. Damper blades shall be galvanized steel with composite gears. Plastic or composite blades on intake or return shall not be acceptable.
 - d. Shall include all hardware and controls to provide free cooling with outdoor air when temperature and/or humidity are below setpoints.
 - e. Shall be equipped with gear driven dampers for both the outdoor ventilation air and the return air for positive air stream control.
 - f. Standard leak rate shall be equipped with dampers not to exceed 2% leakage at 1 in. wg pressure differential.
 - g. Economizer controller on EconoMi\$er IV models shall be Honeywell W7212 that provides:
 - (1.) Combined minimum and DCV maximum damper position potentiometers with compressor staging relay.
 - (2.) Functions with solid state analog enthalpy or dry bulb changeover control sensing.
 - (3.) Contain LED indicates for:
 - when free cooling is available, when module is in DCV mode, when exhaust fan contact is closed.
 - h. Economizer controller on EconoMi\$er X models shall be the Honeywell W7220 that provides:
 - (1.) 2-line LCD interface screen for setup, configuration and troubleshooting.
 - (2.) On-board Fault Detection and Diagnostics (FDD) that senses and alerts when the economizer is not operating properly, per California Title 24.

- (3.) Sensor failure loss of communication identification
 - (4.) Automatic sensor detection
 - (5.) Capabilities for use with multiple-speed indoor fan systems
 - (6.) Utilize digital sensors: Dry bulb and Enthalpy
 - i. Shall be capable of introducing up to 100% outdoor air.
 - j. Shall be equipped with a barometric relief damper capable of relieving up to 100% return air and contain seals that meet ASHRAE 90.1 requirements.
 - k. Shall be designed to close damper(s) during loss-of-power situations with spring return built into motor.
 - l. Dry bulb outdoor air temperature sensor shall be provided as standard. Enthalpy sensor is also available on factory installed only. Outdoor air sensor setpoint shall be adjustable and shall range from 40 to 100°F / 4 to 38°C. Additional sensor options shall be available as accessories.
 - m. The economizer controller shall also provide control of an accessory power exhaust unit function. Factory set at 100%, with a range of 0% to 100%.
 - n. The economizer shall maintain minimum airflow into the building during occupied period and provide design ventilation rate for full occupancy.
 - o. Dampers shall be completely closed when the unit is in the unoccupied mode.
 - p. Economizer controller shall accept a 2–10 Vdc CO₂ sensor input for IAQ/DCV control. In this mode, dampers shall modulate the outdoor air damper to provide ventilation based on the sensor input.
 - q. Compressor lockout temperature on W7220 is adjustable from –45°F to 80°F, set at a factory default of 32°F. Others shall open at 35°F (2°C) and closes at 50°F (10°C).
 - r. Actuator shall be direct coupled to economizer gear. No linkage arms or control rods shall be acceptable.
 - s. Economizer controller shall provide indications when in free cooling mode, in the DCV mode, or the exhaust fan contact is closed.
2. Integrated EconoMi\$er X Ultra Low Leak rate models.(Factory installed on 3 phase models only. Field installed on all 3 and 1 phase models)
- a. Integrated, gear driven opposing modulating blade design type capable of simultaneous economizer and compressor operation.
 - b. Independent modules for vertical or horizontal return configuration shall be available. Vertical return modules shall be available as a factory installed option.
 - c. Damper blades shall be galvanized steel with composite gears. Plastic or composite blades on intake or return shall not be acceptable.
 - d. Shall include all hardware and controls to provide free cooling with outdoor air when temperature and/or humidity are below setpoints.
 - e. Shall be equipped with gear driven dampers for both the outdoor ventilation air and the return air for positive air stream control
 - f. Ultra Low Leak design meets California Title 24 section 140.4 and ASHRAE 90.1 requirements for 4 cfm per sq.ft. on the outside air dampers and 10 cfm per sq. ft. on the return dampers.
 - g. Economizer controller on EconoMi\$er X models shall be the Honeywell W7220 that provides:
 - (1.) 2–line LCD interface screen for setup, configuration and troubleshooting
 - (2.) On–board Fault Detection and Diagnostics (FDD) that senses and alerts when the economizer is not operating properly, per California Title 24.
 - (3.) Sensor failure loss of communication identification
 - (4.) Automatic sensor detection
 - (5.) Capabilities for use with multiple-speed indoor fan systems
 - (6.) Utilize digital sensors: Dry bulb and Enthalpy
 - h. Shall be capable of introducing up to 100% outdoor air.
 - i. Shall be equipped with a barometric relief damper capable of relieving up to 100% return air and contain seals that meet ASHRAE 90.1 requirements.
 - j. Shall be designed to close damper(s) during loss-of-power situations with spring return built into motor.
 - k. Dry bulb outdoor air temperature sensor shall be provided as standard. Enthalpy sensor is also available on factory installed only. Outdoor air sensor setpoint shall be adjustable and shall range from 40 to 100° F / 4 to 38° C. Additional sensor options shall be available as accessories.

- l. The economizer controller shall also provide control of an accessory power exhaust unit function. Factory set at 100%, with a range of 0% to 100%.
 - m. The economizer shall maintain minimum airflow into the building during occupied period and provide design ventilation rate for full occupancy.
 - n. Dampers shall be completely closed when the unit is in the unoccupied mode.
 - o. Economizer controller shall accept a 2–10 Vdc CO₂ sensor input for IAQ/DCV control. In this mode, dampers shall modulate the outdoor air damper to provide ventilation based on the sensor input.
 - p. Compressor lockout temperature on W7220 is adjustable from –45° F to 80° F, set at a factory default of 32° F. Others shall open at 35°F (2°C) and closes at 50°F (10°C).
 - q. Actuator shall be direct coupled to economizer gear. No linkage arms or control rods shall be acceptable.
 - r. Economizer controller shall provide indications when in free cooling mode, in the DCV mode, or the exhaust fan contact is closed.
3. Two–Position Damper (Factory installed on 3 Phase Models Only. Field installed on all 3 and 1 Phase Models)
- a. Damper shall be a Two–Position Damper. Damper travel shall be from the full closed position to the field adjustable %–open setpoint.
 - b. Damper shall include adjustable damper travel from 25% to 100% (full open).
 - c. Damper shall include single or dual blade, gear driven dampers and actuator motor.
 - d. Actuator shall be direct coupled to damper gear. No linkage arms or control rods shall be acceptable.
 - e. Damper will admit up to 100% outdoor air for applicable rooftop units.
 - f. Damper shall close upon indoor (evaporator) fan shutoff and/or loss of power.
 - g. The damper actuator shall plug into the rooftop unit’s wiring harness plug. No hard wiring shall be required.
 - h. Outside air hood shall include aluminum water entrainment filter
4. Manual damper
- a. Manual damper package shall consist of damper, air inlet screen, and rain hood which can be pre-set to admit up to 50% outdoor air for year round ventilation.
5. Hot Gas ReHeat Dehumidification System (3 Phase Models Only).
- a. The Hot Gas ReHeat Dehumidification System shall be factory–installed and shall provide greater dehumidification of the occupied space by two modes of dehumidification operations beside its normal design cooling mode:
 - (1.) Subcooling mode further subcools the hot liquid refrigerant leaving the condenser coil when both temperature and humidity in the space are not satisfied.
 - (2.) Hot gas reheat mode shall mix a portion of the hot gas from the discharge of the compressor with the hot liquid refrigerant leaving the condenser coil to create a two–phase heat transfer in the system, resulting in a neutral leaving– air temperature when only humidity in the space is not satisfied.
 - (3.) Includes Head Pressure Controller.
6. Head Pressure Control Package
- a. Controller shall control coil head pressure by condenser–fan speed modulation or condenser–fan cycling and wind baffles.
 - b. Shall consist of solid–state control and condenser–coil temperature sensor to maintain condensing temperature between 90° F (32° C) and 110° F (43° C) at outdoor ambient temperatures down to –20° F (–29° C).
7. Condenser Coil Hail Guard Assembly (Factory installed on 3 Phase Models Only. Field installed on all 3 and 1 Phase Models)
- a. Shall protect against damage from hail.
 - b. Shall be louvered design.
8. Unit–Mounted, Non–Fused Disconnect Switch (Available on units with MOCP’s of 80 amps or less):
- a. Switch shall be factory–installed, internally mounted.
 - b. National Electric Code (NEC) and UL approved non–fused switch shall provide unit power shutoff.
 - c. Shall be accessible from outside the unit
 - d. Shall provide local shutdown and lockout capability.
9. Convenience Outlet (3 Phase Models Only):

- a. Non-Powered convenience outlet.
 - (1.) Outlet shall be powered from a separate 115/120v power source.
 - (2.) A transformer shall not be included.
 - (3.) Outlet shall be factory-installed and internally mounted with easily accessible 115-v female receptacle.
 - (4.) Outlet shall include 15 amp GFI receptacles with independent fuse protection.
 - (5.) Outlet shall be accessible from outside the unit.
 - (6.) Outlet shall include a field-installed "Wet in Use" cover.
10. Thru-the-Base Connectors:
 - a. Kits shall provide connectors to permit electrical connections to be brought to the unit through the unit basepan.
 - b. Minimum of four connection locations per unit.
11. Propeller Power Exhaust:
 - a. Power exhaust shall be used in conjunction with an integrated economizer.
 - b. Independent modules for vertical or horizontal return configurations shall be available.
 - c. Horizontal power exhaust is shall be mounted in return ductwork.
 - d. Power exhaust shall be controlled by economizer controller operation. Exhaust fans shall be energized when dampers open past the 0-100% adjustable setpoint on the economizer control.
12. Roof Curbs (Vertical):
 - a. Full perimeter roof curb with exhaust capability providing separate air streams for energy recovery from the exhaust air without supply air contamination.
 - b. Formed galvanized steel with wood nailer strip and shall be capable of supporting entire unit weight.
 - c. Permits installation and securing of ductwork to curb prior to mounting unit on the curb.
13. Thru-the-Bottom Utility Connectors:
 - a. Kit shall provide connectors to permit gas and electrical connections to be brought to the unit through the basepan.
14. Outdoor Air Enthalpy Sensor:
 - a. The outdoor air enthalpy sensor shall be used to provide single enthalpy control. When used in conjunction with a return air enthalpy sensor, the unit will provide differential enthalpy control. The sensor allows the unit to determine if outside air is suitable for free cooling.
15. Return Air Enthalpy Sensor:
 - a. The return air enthalpy sensor shall be used in conjunction with an outdoor air enthalpy sensor to provide differential enthalpy control.
16. Indoor Air Quality (CO₂) Sensor:
 - a. Shall be able to provide demand ventilation indoor air quality (IAQ) control.
 - b. The IAQ sensor shall be available in duct mount, wall mount, or wall mount with LED display. The setpoint shall have adjustment capability.
17. Smoke detectors (factory-installed only):
 - a. Shall be a Four-Wire Controller and Detector.
 - b. Shall be environmental compensated with differential sensing for reliable, stable, and drift-free sensitivity.
 - c. Shall use magnet-activated test/reset sensor switches.
 - d. Shall have tool-less connection terminal access.
 - e. Shall have a recessed momentary switch for testing and resetting the detector.
 - f. Controller shall include:
 - (1.) One set of normally open alarm initiation contacts for connection to an initiating device circuit on a fire alarm control panel.
 - (2.) Two Form-C auxiliary alarm relays for interface with rooftop unit or other equipment.
 - (3.) One Form-C supervision (trouble) relay to control the operation of the Trouble LED on a remote test/reset station.
 - (4.) Capable of direct connection to two individual detector modules.
 - (5.) Can be wired to up to 14 other duct smoke detectors for multiple fan shutdown applications.
18. Winter start kit
 - a. Shall contain a bypass device around the low pressure switch.

- b. Shall be required when mechanical cooling is required down to 25°F (−4°C).
 - c. Shall not be required to operate on an economizer when below an outdoor ambient of 40°F (4°C).
19. Time Guard
- a. Shall prevent compressor short-cycling by providing a 5-minute delay (±2 minutes) before restarting a compressor after shutdown for any reason.
 - b. One device shall be required per compressor.
20. Electric Heat:
- a. Heating Section
 - (1.) Heater element open coil resistance wire, nickel-chrome alloy, 0.29 inches inside diameter, strung through ceramic insulators mounted on metal frame. Coil ends are staked and welded to terminal screw slots.
 - (2.) Heater assemblies are provided with integral fusing for protection of internal heater circuits not exceeding 48 amps each. Auto reset thermo limit controls, magnetic heater contactors (24 v coil) and terminal block all mounted in electric heater control box (minimum 18 ga galvanized steel) attached to end of heater assembly.
21. Hinged Access Panels
- a. Shall provide easy access through integrated quarter turn latches.
 - b. Shall be on major panels of: filters, control box, fan motor and compressor.

ACCESSORIES – RAX036–60

ECONOMIZERS			
ECONOMISER IV (FOR 1-SPEED INDOOR FAN MOTOR ONLY) – STANDARD LEAK CONTROLLER INCLUDED			
VERTICAL			
Model Number	Description	Use With Model Size	Approx Ship Wt. LBS (KGS)
CRECOMZR020A02	STANDARD LEAK Vertical EconoMi\$er IV with solid-state controller, gear-driven, damper, spring return actuator, up to 100% barometric relief, supply and outdoor air temperature sensors, and CO2 sensor compatible, for use in non-DDC applications.	036-060 Elect Mech Controls	55 (25)

- ¹ EconoMi\$er IV cannot be installed with an EconoMi\$er X, Manual Damper, or Motorized Damper.
- ² When installed on a unit with hinged panels, hinged panel access kit is also required.

HORIZONTAL			
Model Number	Description	Use With Model Size	Approx Ship Wt. LBS (KGS)
CRECOMZR024A02	STANDARD LEAK Horizontal EconoMi\$er IV with solid-state controller, gear-driven, modulating damper, spring return actuator, up to 100% barometric relief, supply and outdoor air temperature sensors, and CO2 sensor compatible, for use in non-DDC applications.	036-060 Elect Mech Controls	85 (39)

- ¹ EconoMi\$er IV cannot be installed with an EconoMi\$er X, Manual Damper, or Motorized Damper.
- ² When installed on a unit with hinged panels, hinged panel access kit is also required.

ECONOMIZER X (FOR 1 & 2-SPEED INDOOR FAN MOTOR) – STANDARD LEAK, CONTROLLER INCLUDED			
VERTICAL			
Model Number	Description	Use With Model Size	Approx Ship Wt. LBS (KGS)
CRECOMZR076A00	STANDARD LEAK - Vertical EconoMi\$er X with solid-state W7220 controller, gear-driven, modulating damper, spring return actuator, up to 100% barometric relief, supply and outdoor air temperature sensors, and CO2 sensor compatible, for use in electro mechanical controls only. Controller meets California Title 24 Section 120.2 Fault Detection and Diagnostic (FDD) requirements.	036-060 Elect Mech Controls	105 (48)

- ¹ EconoMi\$er X cannot be installed with an EconoMi\$er IV, Manual Damper or Motorized Damper.
- ² When installed on a unit with hinged panels, hinged panel access kit is also required.

HORIZONTAL			
Model Number	Description	Use With Model Size	Approx Ship Wt. LBS (KGS)
CRECOMZR077A00	STANDARD LEAK - Horizontal EconoMi\$er X with solid-state W7220 controller, gear-driven, modulating damper, spring return actuator, up to 100% barometric relief, supply and outdoor air temperature sensors, and CO2 sensor compatible, for use in electro mechanical controls only. Controller meets California title 24 Section 120.2 Fault Detection and Diagnostic (FDD) requirements.	036-060 Elect Mech Controls	105 (48)

- ¹ EconoMi\$er X cannot be installed with an EconoMi\$er IV, Manual Damper or Motorized Damper.
- ² When installed on a unit with hinged panels, 3 hinged panel access kit is also required.

ECONOMISER X (FOR 1 & 2-SPEED INDOOR FAN MOTOR) – ULTRA LOW LEAK, CONTROLLER INCLUDED			
VERTICAL			
Model Number	Description	Use With Model Size	Approx Ship Wt. LBS (KGS)
CRECOMZR067A00	Ultra LOW LEAK - Vertical EconoMi\$er X with solid-state W7220 controller, gear-driven, modulating damper, spring return actuator, up to 100% barometric relief, supply and outdoor air temperature sensors, and CO2 sensor compatible, for use in electro mechanical controls only. Also includes return , outside air, and relief air damper leakage that meets Title 24 section 140.4 and ASHRAE 90.1 requirements. Controller meets California Title 24 Fault Detection and Diagnostic (FDD) requirements.	036-060 Elect Mech Controls	105 (48)

- ¹ EconoMi\$er X cannot be installed with an EconoMi\$er IV, Manual Damper or Motorized Damper.
- ² Currently only available on vertical air flow configuration models. Contact your local MicroMetl account manager 1-800-884-4662 if horizontal model is required.
- ³ When installed on a unit with hinged panels, hinged panel access kit is also required.

ACCESSORIES – RAX036–60 (cont.)

ACCESSORY KITS FOR UNITS WITH HINGED ACCESS PANELS		
VERTICAL		
Model Number	Description	Use With Model Size
CRPECONV003A00	Vertical accessory kit is required when field installing a vertical economizer on a unit that has hinged access panels. Includes angle and seal strip.	036-060
HORIZONTAL		
Model Number	Description	Use With Model Size
CRHNGPNL001A00	Horizontal accessory kit is required when field installing a horizontal economizer on a unit that has hinged access panels. Includes door panel, angle and seal strip.	036-060

ECONOMIZER SENSORS		
Model Number	Description	Use With Model Size
DNTEMPSN002A00	Outdoor or Return Dry Bulb Temperature Sensor used with Electro-Mechanical control.	ECONOMIZER IV
DNCBDIOX005A00	CO ₂ Sensor for use in return airstream. Also includes Aspirator Box required for Duct Mounting.	ECONOMIZER IV & X
DNENTDIF004A00	Return Air Enthalpy Sensor used with Electro-Mechanical controls, use with AXB078ENT for differential enthalpy control.	ECONOMIZER IV
AXB078ENT	Accusensor II Economizer Differential Enthalpy Control Upgrade	ECONOMIZER IV
CRTEMPSN005A00	Outdoor or return dry bulb temperature sensor used with Honeywell W7220 electro-mechanical control.	ECONOMIZER X
--HH--57AC-081	Enthalpy control for W7220 controller only. (One required for single enthalpy, two required for differential enthalpy)	ECONOMIZER X

NOTE: Supply air temperature sensor (SAT and low ambient lockout switch) provided with economizer IV or economizer X.

¹ Supply air temperature sensor (SAT and low ambient lockout switch) provided with Economi\$er IV or EconoMiZer X.

ECONOMIZER SENSOR USAGE CHART			
DESIRED CONTROL METHOD		ECONOMI\$ER IV ¹ REQUIRED FIELD-INSTALLED SENSOR(S)	ECONOMI\$ER X ¹ REQUIRED FIELD-INSTALLED SENSOR(S)
Single Dry Bulb Control		None. Outside Air dry bulb sensor is factory installed.	None. Outside Air dry bulb sensor is factory installed.
Single Enthalpy Control		(1) AXB078ENT	(1) --HH--57AC-081
Differential Dry Bulb		NA	(1) – HH—57AC-081
Differential Enthalpy Control		(1) AXB078ENT & (1) DNENTDIF004A00	(2) --HH--57AC-081
To Add CO ₂ DCV Control with above:	Duct Mount	(1) DNCBDIOX005A00	(1) DNCBDIOX005A00

¹ OAT and SAT sensors included for EconoMi\$er IV.or EconoMiZer X

POWER EXHAUST		
VERTICAL ^{1, 2}		
Model Number	Description	Use With Model Size
DNPWREXH030A01	Vertical Power Exhaust 208/230 volt (1 or 3 Phase)	036 – 060
DNPWREXH021A01	Vertical Power Exhaust 460 volt	036 – 060

¹ Vertical Power Exhaust requires a vertical Economizer

² Vertical Power Exhaust package includes exhaust hood, screens, and propeller fan system

HORIZONTAL ^{1, 2}		
Model Number	Description	Use With Model Size
DNPWREXH028A01	Horizontal Power Exhaust 208/230 & 575 volt (1 or 3 Phase)	036 – 060
DNPWREXH029A01	Horizontal Power Exhaust 460 volt	036 – 060

¹ Horizontal Power Exhaust should be duct-mounted in the return duct and is supplied with a single fan and wiring harness

² Horizontal Power Exhaust package includes exhaust hood, screens, and propeller fan system

ACCESSORIES – RAX036–60 (cont.)

575V TRANSFORMER		
Model Number	Description	Use With Model Size
1171494 *	Transformer for conversion from 575v to 208/230v power exhaust applications.	ALL

NOTE:

- 24" Roof curbs are NOT required with vertical power exhaust.
 - Both vertical and horizontal power exhaust packages can be used with either EconoMi\$er IV or EconoMi\$er X. In either case, the power exhaust is controlled by the EconoMi\$er IV, X controller.
- * Order --HT--01AH-859, FAST# 1171494, for 575V applications.

MANUAL OUTDOOR AIR DAMPERS		
Model Number	Description	Use With Model Size
CRMANDPR001A03	25% Open Manual Fresh Air Damper	036 – 060
CRMANDPR001A02	50% Open Manual Fresh Air Damper	036 – 060

MOTORIZED OUTDOOR AIR DAMPERS		
Model Number	Description	Use With Model Size
CRTWOPOS010A00	Motorized 2 position outdoor air damper (25–100% Outdoor Air)	036 – 060

NOTE: Economizer IV, Economizer X, Manual Damper and 2-Position damper are all mutually exclusive and cannot be installed together.

- Manual dampers include hood assembly, bird screen, adjustable damper blade (to allow up to the rated outdoor air %), and bottom panel with opening.
 - Motorized dampers include bottom panel with opening (100% two-position damper includes 30% barometric relief capability), and adjustable damper (to allow up to the rated outdoor air %)
 - Motorized dampers will close on loss of power to the rooftop unit.
- Manual and motorized dampers are not compatible with a vertical power exhaust module.

LOUVERED HAIL GUARDS – CONDENSER COIL		
Model Number	Description	Use With Model Size
CRLVHLGD012A00	Louvered Condenser Coil Hail Guard -- Includes louvered panel(s) to protect condenser coil from damage and vandalism.	036 – All Voltages 048 – 1 Phase Only
CRLVHLGD011A00	Louvered Condenser Coil Hail Guard -- Includes louvered panel(s) to protect condenser coil from damage and vandalism.	048 – 3 Phase Only
CRLVHLGD013A00	Louvered Condenser Coil Hail Guard -- Includes louvered panel(s) to protect condenser coil from damage and vandalism.	060 – 1 Phase Only
CRLVHLGD045A00	Louvered Condenser Coil Hail Guard -- Includes louvered panel(s) to protect condenser coil from damage and vandalism.	060 – 3 Phase Only

STANDARD ROOF CURBS		
Model Number	Description	Use With Model Size
CRRFCURB001A01	14" (356 mm) High Roof Curb. Ductwork attaches to the roof curb. Includes thru-the-bottom capability.	036 – 060
CRRFCURB002A01	24" (607 mm) High Roof Curb. Ductwork attaches to the roof curb. Includes thru-the-bottom capability.	036 – 060

THROUGH-THE-BOTTOM/CURB POWER CONNECTION		
Model Number	Description	Use With Model Size
CRBTMPWR001A01	Thru-the-bottom electrical connections and thru-the-curb (not thru the bottom) gas connections. Includes a 3/4-inch (19 mm) diameter liquid tight conduit fitting for high voltage power wires and (2) 1/2-inch (13 mm) diameter liquid tight conduit fittings for thermostat wires and convenience outlet wires. Includes a 3/4-inch (19 mm) inside pipe coupling and gas plate assembly for thru-the-curb connections. Provides for watertight seals.	036-060
CRBTMPWR003A01	Thru-the bottom power, control and gas connections. Includes a 3/4-inch diameter liquid tight conduit fitting for high voltage power wires, (2) 1/2- inch diameter liquid tight conduits for thermostat wires and convenience outlet wires and 1/2-inch gas adapter fitting for gas piping. Provides for watertight seal.	036-060

NOTE: Access to the bottom of the RTU is required to install a THRU-THE-BOTTOM Connection Kit. Recommend installing kit prior to installing RTU on roof curb.

ACCESSORIES – RAX036–60 (cont.)

CONTROL UPGRADE KITS		
Model Number	Description	Use With Model Size
NRTIMEGD001A00	Time Guard II -- Automatically prevents the compressor from restarting for at least 4 minutes and 45 seconds after shutdown of the compressor. Not required when a commercial thermostat has a minimum 5 min time delay between cooling cycles available (One required per unit)	All
DNWINSTR001A00	Winter Start Package - Contains time delay relay for timed bypass of low pressure switch on startup.(One required per refrigerant circuit) ¹	All
CRPHASE3001A02	Phase Monitor Control - Provides phase loss/phase reversal protection	All 3 Phase 208/230-3-60 460-3-60
CRPHASE3002A00	Phase Monitor Control - Provides phase loss/phase reversal protection	All 3 Phase 575v
CRSDTEST001A00	Remote keyed attenuator / test / reset station for use with factory installed smoke detectors. Includes power, alarm & trouble indicator lights.	All

¹ If mechanical cooling below 25 degrees ambient is necessary, consider additional low-ambient control measures (for example, economizer or motormaster)

LOW AMBIENT CONTROLS *		
Model Number	Description	Use With Model Size
CPLOWAMB001A00	Motormaster® II Low Ambient Control - Enables cooling system to operate down to 0°F (-18° C) by cycling condenser fan on and off. The control is activated by a temperature sensor. No motor change-out required. One required per unit.	All Sizes 208/230-1-60 208/230-3-60 460-3-60 **
HC40GE231 / 1178185 ¹	Motormaster I Compatible Ball Bearing Fan Motor	036 – 208/230-1-60 208/230–3–60, 575–3–60†
HC40GE461 / 1178186 ¹	Motormaster I Compatible Ball Bearing Fan Motor	036 – 460-3-60
HC40GE233 / 1171974 ¹	Motormaster I Compatible Condenser Fan Motor	048–060 – 208/230-1-60 208/230-3-60, 575–3–60†
HC40GE463 / 1171975 ¹	Motormaster I Compatible Condenser Fan Motor	048–060 – 460–3–60
32LT-900---301	Motormaster I Single-Phase Solid-State Variable Speed Motor Controller enables cooling down to -20°F by varying the speed on the condenser fan.	All Sizes 208/230-1-60 208/203-3-60
32LT-900---611	Motormaster I Single-Phase Solid-State Variable Speed Motor Controller enables cooling down to -20° F (-29° C) by varying the speed on the condenser fan.	All Sizes 460-3-60
HC91CL010 / 1171807 ¹	MFD 10	Refer to MotorMaster I usage table

¹ Available from FAST Parts.

† Transformer HT01AH856 (0.75kva, 575V to 230V) and transformer bracket 50DK502263 is required

* See usage tables in kit instructions.

** One DNWINSTR001A00 also required per refrigerant circuit.

Sizes 036-060 require one (1) Low Ambient Controller and one (1) compatible condenser fan motor for change-out.