



SOUTHWARK METAL MANUFACTURING COMPANY

Philadelphia, PA • Greenville, SC • Indianapolis, IN • Southaven, MS • Fremont, NE • Caldwell, ID

Corporate Headquarters: 2800 Red Lion Road, Philadelphia PA 19114

tel: (800) 523-1052 • fax (800) 722-2076 • www.southwarkmetal.com

SUBMITTAL DRAWING

**HIGH EFFICIENCY AIR-TITE RECTANGULAR TAKEOFF
(MODEL NO:ATHE)**

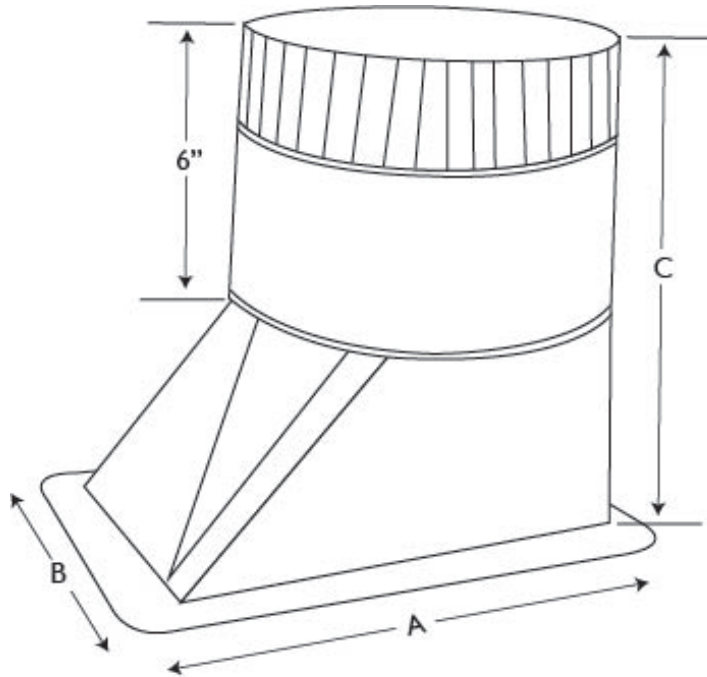

Diameter	A	B	C
4"	6"	6"	11"
5"	10"	6"	10"
6"	10"	6"	10"
7"	10"	6"	10½"
8"	12"	8"	11"
9"	12"	9"	11"
10"	14"	10"	11"
12"	18"	12"	13"
14"	18"	12"	13"
16"	18"	12"	13¼"

NOTES

- Fabricated from 26 Ga galvanized steel
- Rectangular opening
- Designed with an appropriate 45° slope on the body
- 1" flange on all sides with neoprene gasket
- 1.875" crimp

JOB NAME: _____
 LOCATION: _____
 ARCHITECT: _____
 ENGINEER: _____
 CONTRACTOR: _____

DATE: 07/24/12 SW-ATHEIN SD-0027

High Efficiency Air Tite Rectangular Take Off
 MODEL NO:ATHE