

OptiPure

Snapshot

The **CTOS-CK10** is a compatible replacement cartridge for the Cuno® 8000 series filter replacement cartridges. It is a 10" quick-change cartridge that reduces sediment down to 0.5 microns and reduces chlorine, taste & odor at a flow rate of 1.5 gpm for 15,000 gallons. The cartridge includes IsoNet®, OptiPure's patented scale-inhibiting technology, which delivers consistent protection against the precipitation and accumulation of scale and provides a protective barrier to help guard against corrosion.

Cartridge Benefits

- IsoNet® - OptiPure's patented scale inhibiting technology delivers up to 5 times more protection against scale and corrosion than most 8000 series cartridges.
- Improves the quality and consistency of cold and hot beverages.
- Gradient-density sediment filtration protects against dirt, rust and other debris down to 0.5 microns.
- High-capacity activated-carbon filtration makes water taste great and protects equipment against corrosive chlorine.
- Provides more capacity than most 8000 series cartridges.
- Replaces 3M® Cuno® 8000 Series sanitary quick change cartridges that include scale inhibition.

Model: **CTOS-CK10**
Part #: 300-08015

REPLACEMENT CARTRIDGE

ITEM #: _____ QTY: _____

JOB NAME/NUMBER _____



Application

- Replacement cartridge for 3M® Cuno® CFS8112S, CFS8112ELS, CFS8112XS, CFS8720S and CFS8720ELS cartridges.
- Ice machines, coffee brewers and steam equipment.

Installation Tips

- Insure cartridge is designed to replace the existing cartridge.
- Do not exceed cartridge specifications for temperature and pressure.
- Allow 3" clearance below system for filter cartridge removal and replacement.
- No activation procedure or flushing is required for cartridge to perform as specified.
- Feed-water connection to system should be COLD only.



Model: **CTOS-CK10**

Part #: 300-08015

► Specifications

Cartridge	
Dimensions (Height x Width x Depth, inches)	12" x 4" x 4"
Operating Pressure Range	10-125 psi (0.7 -8.6 bar)
Inlet Water Temperature Range	35 - 100°F (2 - 38°C)
Shipping Weight	5 lbs.
Performance	
Chlorine, Taste and Odor Reduction Capacity	15,000 gals. (53,781 liters)
Service Flow Rate	1.5 gpm (5.7 lpm)
Sediment Reduction	0.5 micron (nominal)
Scale & Corrosion Inhibitor	IsoNet® (100 grams)

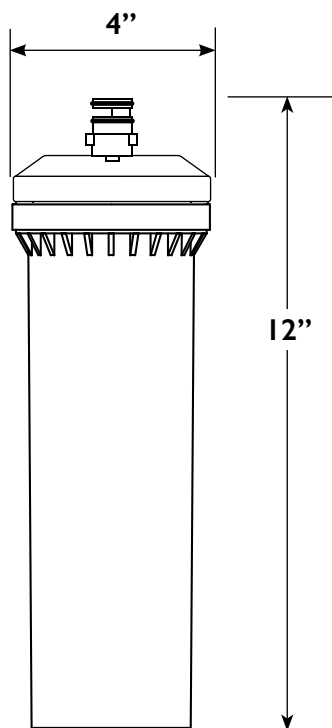

► Replaces CUNO Cartridges

Model	Part Number
CFS8112 S	5581708
CFS8112 ELS	5581727
CFS8112 XS	5601103
CFS8720 S	5631904
CFS8720 ELS	5632001

It is recommended that filters be changed every 6 months, when capacity is reached or when effluent pressure or flow becomes inadequate.

This product is for commercial use only and must be installed and maintained according to manufacturer's guidelines.

Do not use on water that is microbiologically unsafe or of unknown quality without adequate disinfection before or after the system.

Dealer/Distributor Info:

► Warranty

OptiPure Cartridges are warranted against defects in material and workmanship up to one year or when cartridge capacity is reached. Claims of capacity or rated service life are not applicable for mechanical filtration. For complete warranty information, contact OptiPure customer service.

OptiPure, a division of AQUION
2605 Technology Dr., Bldg 300 Plano, TX 75074
p: 972.881.9797; f: 972.422.6262
e: info@optipure.net www.optipurewater.com