

ITEM #: _____ QTY: _____

JOB NAME/NUMBER _____

Snapshot

The QT-1 is a single-cartridge water treatment system with a 15" Qwik-Twist cartridge that reduces sediment down to 0.5 microns and reduces chlorine, taste & odor at a flow rate of 2.25 gpm for 22,500 gallons.

System Benefits

- Improves quality and consistency of cold and hot beverages.
- Reduces maintenance frequency and cost, and extends equipment life.
- Gradient-density sediment filtration protects against dirt, rust and other debris down to 0.5 microns.
- High-capacity activated-carbon filtration makes water taste great and protects equipment against corrosive chlorine.
- Sturdy mounting bracket and full-flow inlet shut-off valve simplify installation.
- Built-in pressure gauge allows visual monitoring of when filters need to be changed.
- Inlet shut-off valve makes filter replacement quick and simple.
- Utilizes 'Qwik-Twist' cartridges that make changing filters quick, easy and sanitary.
- NSF Certified under Standard 42.



Application

FOUNTAIN BEVERAGES - *Single carbonator.*

COFFEE & TEA - *Applications where water hardness is not a problem.*

DRINKING WATER

Installation Tips

- Feed-water connection to system should be COLD only.
- Do not exceed system specifications for temperature and pressure.
- Allow 3" clearance below system for filter cartridge removal and replacement.
- Detailed installation, operation & maintenance manual included with each system.
- No activation procedure or flushing required for system to perform as specified.

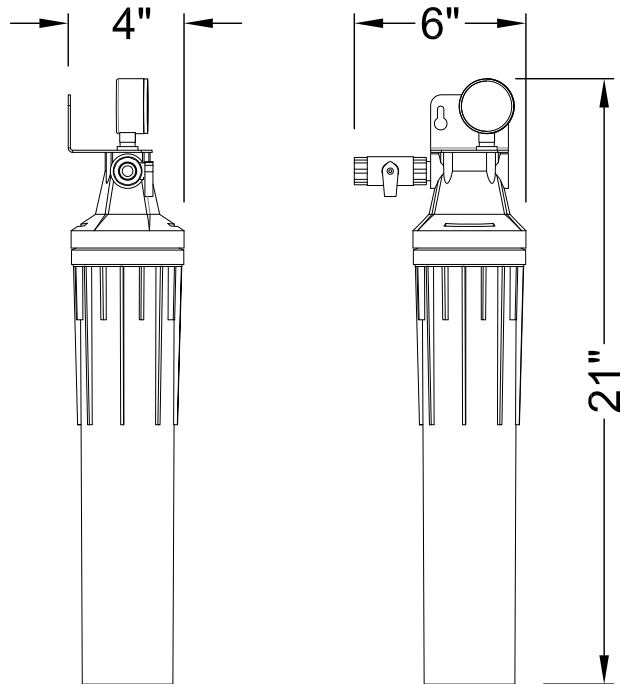

System Tested and Certified by NSF International against NSF/ANSI Standard 42 Aesthetic Effects - Particulate Reduction (Class I) and the reduction of Chlorine, Taste and Odor.

► Warranty

Systems have a 60 month warranty against defects in material and workmanship. For complete warranty information, contact OptiPure customer service.

Dealer/Distributor Info:

► Specifications

System	
Dimensions (Height x Width x Depth, inches)	21" x 6" x 4"
Connection - Inlet & Outlet	3/8" NFPT
Operating Pressure Range	10 - 125 psi (0.7 - 8.6 bar)
Inlet Water Temperature Range	35° - 100°F (2° - 38°C)
Shipping Weight	5 lbs.
Performance	
Chlorine, Taste and Odor Reduction Capacity	22,500 gals. (85,162 liters)
Service Flow Rate	2.25 gpm (8.5 lpm)
Sediment Reduction	0.5 micron (nominal)
Scale & Corrosion Inhibitor	N/A

Optional Flush Valve Kit - Part #: 160-52912

► Replacement Cartridge(s)

Model	Part Number	Qty
CTO-Q	300-05830	1

It is recommended that filters be changed every six months, when capacity is reached or when effluent pressure or flow becomes inadequate.

This product is for commercial use only and must be installed and maintained according to manufacturer's guidelines.

Do not use on water that is microbiologically unsafe or of unknown quality without adequate disinfection before or after the system.

OptiPure, a division of AQUION
2605 Technology Dr., Bldg 300 Plano, TX 75074
p: 972.881.9797; f: 972.422.6262
e: info@optipure.net www.optipurewater.com