

OptiPure

Model: **FX-12**

Part #: **160-50020**

Snapshot

The FX-12 is a single-housing water treatment system with a drop-in 20" cartridge that reduces sediment down to 0.5 microns and reduces chlorine, taste & odor at a flow rate of 3.0 gpm for 30,000 gallons.

System Benefits

- Improves quality and consistency of cold and hot beverages.
- Reduces maintenance frequency and cost, and extends equipment life.
- Gradient-density sediment filtration protects against dirt, rust and other debris down to 0.5 microns.
- High-capacity activated-carbon filtration makes water taste great and protects equipment against corrosive chlorine.
- Sturdy mounting bracket and full-flow inlet shut-off valve simplify installation.
- Built-in pressure gauge allows visual monitoring of when filters need to be changed.
- Inlet shut-off and depressurization valves make filter replacement quick and simple.
- Minimizes waste by only replacing drop-in cartridge and reusing filter sump.
- NSF Certified under Standard 42.

ITEM #: _____ QTY: _____

JOB NAME/NUMBER _____



Application

FOUNTAIN BEVERAGES - 1 or 2 carbonators.

COFFEE & TEA - High-volume applications where water hardness is not a problem.

DRINKING WATER

Installation Tips

- Feed-water connection to system should be COLD only.
- Do not exceed system specifications for temperature and pressure.
- Allow 3" clearance below system for filter housing removal and cartridge replacement.
- Detailed installation, operation & maintenance manual included with each system.
- No activation procedure or flushing required for system to perform as specified.

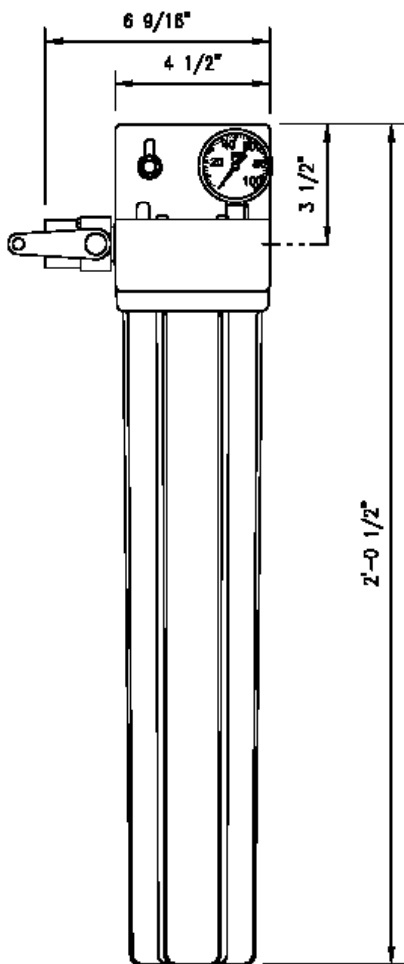

Model FX-12 is Tested and Certified by NSF International against NSF/ANSI Standard 42 Aesthetic Effects - Particulate Reduction (Class I) and the reduction of Chlorine, Taste and Odor.

Dealer/Distributor Info:

► Specifications

System	
Dimensions (Height x Width x Depth, inches)	24-1/2" x 6-9/16" x 5-1/8"
Connection - Inlet & Outlet	1/2" NPT female
Operating Pressure Range	10 - 125 psi (0.7 - 8.6 bar)
Inlet Water Temperature Range	35 - 100°F (2 - 38°C)
Shipping Weight	8 lbs.
Performance	
Chlorine, Taste and Odor Reduction Capacity	30,000 gals (113,550 liters)
Service Flow Rate	3.0 gpm (11.3 lpm)
Sediment Reduction	0.5 micron (nominal)

Optional Flush Valve Kit - Part #: 160-52910

► Replacement Cartridge(s)

Model	Part Number	Qty
CTO-20	252-20120	1

It is recommended that filters be changed every six months, when capacity is reached or when effluent pressure or flow becomes inadequate.

This product is for commercial use only and must be installed and maintained according to manufacturer's guidelines.

Do not use on water that is microbiologically unsafe or of unknown quality without adequate disinfection before or after the system.

► Warranty

Systems have a 3-year warranty against defects in material and workmanship. For complete warranty information, contact OptiPure customer service.

OptiPure, a division of AQUION
2605 Technology Dr., Bldg 300 Plano, TX 75074
p: 972.881.9797; f: 972.422.6262
e: info@optipure.net www.optipurewater.com