

Revision A:

- 3. SPECIFICATION has been modified.
 - 10. TROUBLESHOOTING has been modified.
- Please void OBH684.

OUTDOOR UNIT SERVICE MANUAL



No. OBH684
REVISED EDITION-A

Models

MUZ-FH09NA
MUZ-FH12NA
MUZ-FH15NA

MUZ-FH09NAH
MUZ-FH12NAH
MUZ-FH15NAH

Indoor unit service manual
MSZ-FH•NA Series (OBH683)

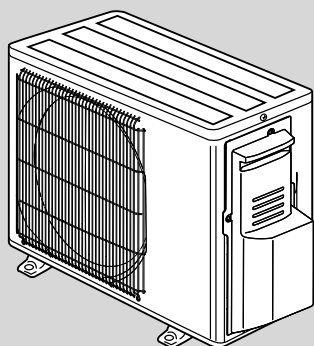

MUZ-FH09NA MUZ-FH09NAH
MUZ-FH12NA MUZ-FH12NAH

CONTENTS

| | |
|-------------------------------------|----|
| 1. TECHNICAL CHANGES | 2 |
| 2. PART NAMES AND FUNCTIONS..... | 3 |
| 3. SPECIFICATION..... | 4 |
| 4. OUTLINES AND DIMENSIONS | 6 |
| 5. WIRING DIAGRAM..... | 8 |
| 6. REFRIGERANT SYSTEM DIAGRAM | 11 |
| 7. DATA | 13 |
| 8. ACTUATOR CONTROL..... | 21 |
| 9. SERVICE FUNCTIONS | 22 |
| 10. TROUBLESHOOTING | 23 |
| 11. DISASSEMBLY INSTRUCTIONS | 44 |

PARTS CATALOG (OBB684)

NOTE:

RoHS compliant products have <G> mark on the spec name plate.

Use the specified refrigerant only

Never use any refrigerant other than that specified.

Doing so may cause a burst, an explosion, or fire when the unit is being used, serviced, or disposed of.

Correct refrigerant is specified in the manuals and on the spec labels provided with our products.

We will not be held responsible for mechanical failure, system malfunction, unit breakdown or accidents caused by failure to follow the instructions.

Revision A:

- 3. SPECIFICATION has been modified.
(The values of COP have been modified.)
- 10. TROUBLESHOOTING has been modified.

1

TECHNICAL CHANGES

MUZ-FH09NA **MUZ-FH09NAH**

MUZ-FH12NA **MUZ-FH12NAH**

MUZ-FH15NA **MUZ-FH15NAH**

1. New model

2

PART NAMES AND FUNCTIONS

MUZ-FH09NA MUZ-FH12NA
MUZ-FH09NAH MUZ-FH12NAH

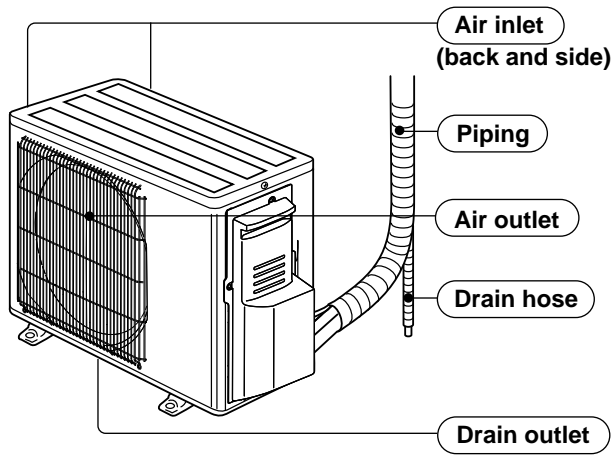

MUZ-FH15NA MUZ-FH15NAH

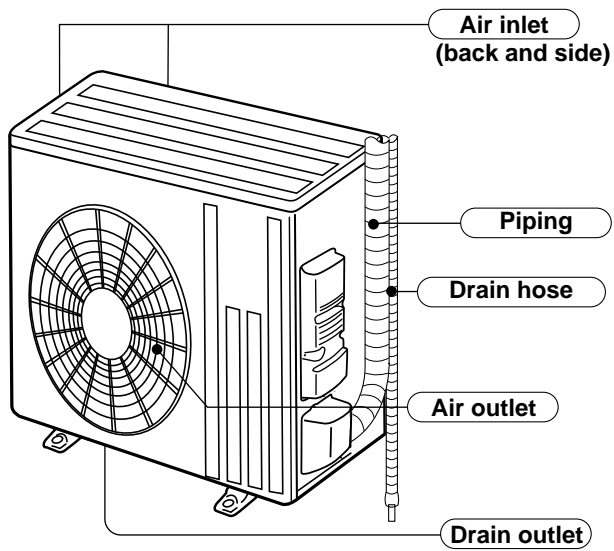

| Outdoor unit model | | | MUZ-FH09NA MUZ-FH09NAH | MUZ-FH12NA MUZ-FH12NAH | MUZ-FH15NA MUZ-FH15NAH |
|--|------------------------|-----------------------------|---------------------------|---------------------------|---------------------------|
| Capacity Rated (Minimum-Maximum) | Cooling *1 | Btu/h | 9,000 (1,700 ~ 12,000) | 12,000 (2,500 ~ 13,600) | 15,000 (6,450 ~ 19,000) |
| | Heating 47 *1 | Btu/h | 10,900 (1,600 ~ 18,000) | 13,600 (3,700 ~ 21,000) | 18,000 (5,150 ~ 24,000) |
| Capacity Rated (Maximum) | Heating 17 *2 | Btu/h | 6,700 (12,200) | 8,000(13,600) | 11,000 (18,000) |
| Power consumption Rated (Minimum-Maximum) | Cooling *1 | W | 560 (100 ~ 1,000) | 870 (170 ~ 1,150) | 1,200 (410 ~ 2,200) |
| | Heating 47 *1 | W | 710 (110 ~ 1,470) | 950 (280 ~ 2,300) | 1,300 (430 ~ 3,360) |
| Power consumption Rated (Maximum) | Heating 17 *2 | W | 600 (1,440) | 720 (1,900) | 1,020 (2,480) |
| EER *1 [SEER] *3 | Cooling | | 16.1 [30.5] | 13.8 [26.1] | 12.5 [22.0] |
| HSPF IV *4 | Heating | | NA: 13.5 | NA: 12.5 | NA: 12.0 |
| | | | NAH: 12.5 | NAH: 11.5 | NAH: 11.0 |
| COP | Heating *1 | | 4.50 | 4.20 | 4.06 |
| Power supply | V , phase , Hz | | 208/230, 1 , 60 | | |
| Max. fuse size (time delay) | A | | 15 | | 20 |
| Min. circuit ampacity | A | | 11 | | 16 |
| Fan motor | F.L.A | | 0.50 | | 0.93 |
| Compressor | Model | | SNB092FQAMT | SNB140FQUMT | SNB172FQKMT |
| | | R.L.A | 8.2 | | 12.0 |
| | | L.R.A | 10.3 | | 15.0 |
| | | Refrigeration oil L (Model) | 0.35 (FV50S) | 0.35 (FV50S) | 0.40 (FV50S) |
| Refrigerant control | Linear expansion valve | | | | |
| Sound level *1 | Cooling | dB(A) | 48 | 49 | 51 |
| | Heating | dB(A) | 49 | 51 | 55 |
| Defrost method | Reverse cycle | | | | |
| Dimensions | W | in. | 31-1/2 | | 33-1/16 |
| | D | in. | 11-1/4 | | 13 |
| | H | in. | 21-5/8 | | 34-5/8 |
| Weight | lb. | | 81 | 83 | 124 |
| External finish | Munsell 3Y 7.8/1.1 | | | | |
| Remote controller | Wireless type | | | | |
| Control voltage (by built-in transformer) | VDC | | 12 - 24 | | |
| Refrigerant piping | Not supplied | | | | |
| Refrigerant pipe size (Min. wall thickness) | Liquid | in. | 1/4 (0.0315) | | |
| | Gas | in. | 3/8 (0.0315) | | 1/2 (0.0315) |
| Connection method | Indoor | | Flared | | |
| | Outdoor | | Flared | | |
| Between the indoor & outdoor units | Height difference | ft. | 40 | | 50 |
| | Piping length | ft. | 65 | | 100 |
| Refrigerant charge (R410A) | | | 2 lb. 9 oz. | | 3 lb. 7 oz. |

NOTE: Test conditions are based on AHRI 210/240.

*1: Rating conditions (Cooling) — Indoor: 80°FDB, 67°FWB, Outdoor: 95°FDB, (75°FWB)
(Heating) — Indoor: 70°FDB, 60°FWB, Outdoor: 47°FDB, 43°FWB

*2: (Heating) — Indoor: 70°FDB, 60°FWB, Outdoor: 17°FDB, 15°FWB

Test condition

*3,*4

| ARI | Mode | Test | Indoor air condition (°F) | | Outdoor air condition (°F) | |
|-----|-------------------|--|---------------------------|----------|----------------------------|----------|
| | | | Dry bulb | Wet bulb | Dry bulb | Wet bulb |
| | SEER (Cooling) | "A-2" Cooling Steady State at rated compressor Speed | 80 | 67 | 95 | (75) |
| | | "B-2" Cooling Steady State at rated compressor Speed | 80 | 67 | 82 | (65) |
| | | "B-1" Cooling Steady State at minimum compressor Speed | 80 | 67 | 82 | (65) |
| | | "F-1" Cooling Steady State at minimum compressor Speed | 80 | 67 | 67 | (53.5) |
| | | "E-V" Cooling Steady State at Intermediate compressor Speed *5 | 80 | 67 | 87 | (69) |
| | HSPF (Heating) | "H1-2" Heating Steady State at rated compressor Speed | 70 | 60 | 47 | 43 |
| | | "H3-2" Heating at rated compressor Speed | 70 | 60 | 17 | 15 |
| | | "H0-1" Heating Steady State at minimum compressor Speed | 70 | 60 | 62 | 56.5 |
| | | "H1-1" Heating Steady State at minimum compressor Speed | 70 | 60 | 47 | 43 |
| | | "H2-V" Heating at Intermediate compressor Speed *5 | 70 | 60 | 35 | 33 |

*5: At Intermediate compressor Speed
= ("Cooling rated compressor speed" - "minimum compressor speed") / 3 + "minimum compressor speed".

OPERATING RANGE

(1) POWER SUPPLY

| | Rated voltage | Guaranteed voltage (V) |
|--------------|-------------------------------|------------------------|
| Outdoor unit | 208/230 V 1 phase 60 Hz | |

(2) OPERATION

| Mode | Condition | Intake air temperature (°F) | | | |
|---------|----------------------|-----------------------------|----|---------|-----|
| | | Indoor | | Outdoor | |
| | | DB | WB | DB | WB |
| Cooling | Standard temperature | 80 | 67 | 95 | — |
| | Maximum temperature | 90 | 73 | 115 | — |
| | Minimum temperature | 67 | 57 | 14 | — |
| | Maximum humidity | 78 % | | — | |
| Heating | Standard temperature | 70 | 60 | 47 | 43 |
| | Maximum temperature | 80 | 67 | 75 | 65 |
| | Minimum temperature | 70 | 60 | -13 | -14 |

MUZ-FH09NA MUZ-FH09NAH MUZ-FH12NA MUZ-FH12NAH

Unit: inch

REQUIRED SPACE

*1 4 in. (100 mm) or more when front and sides of the unit are clear

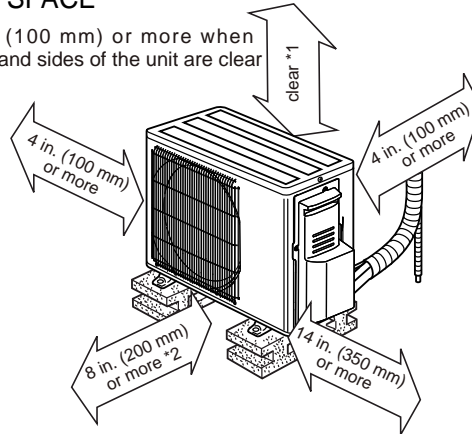

*2 When any 2 sides of left, right and rear of the unit are clear

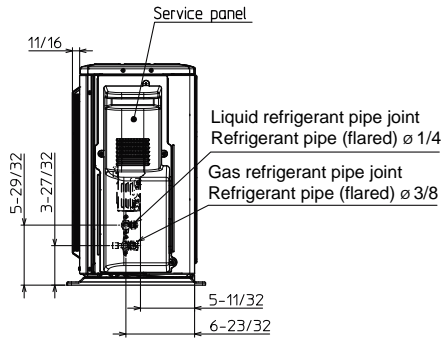
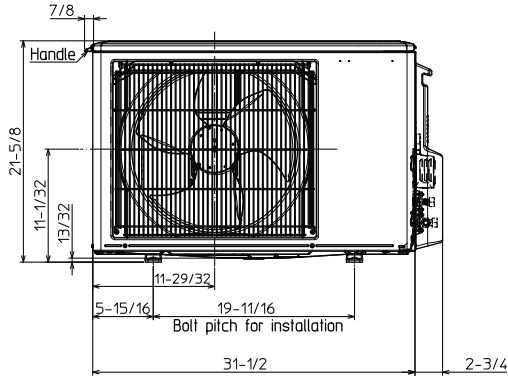
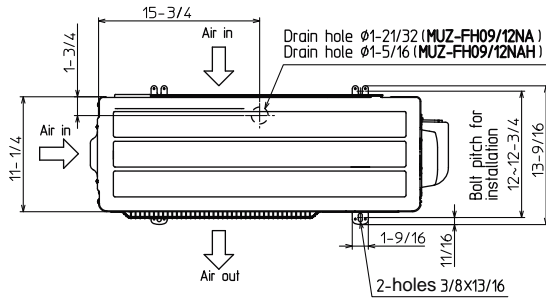

MUZ-FH15NA MUZ-FH15NAH

Unit: inch

REQUIRED SPACE

*1 20 in. (500 mm) or more when front and sides of the unit are clear

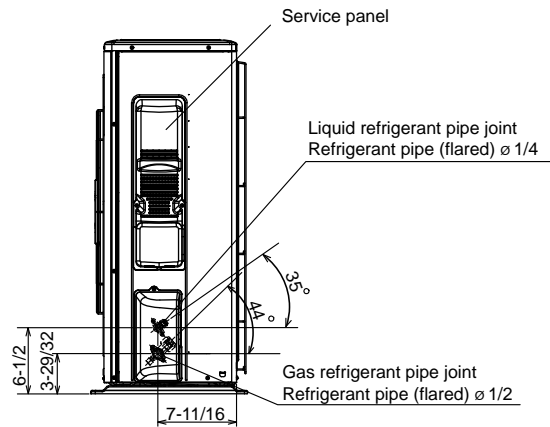
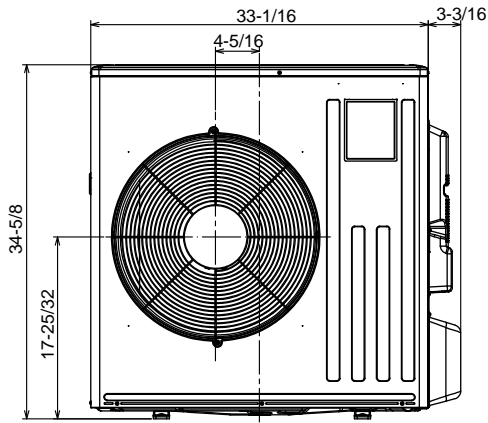
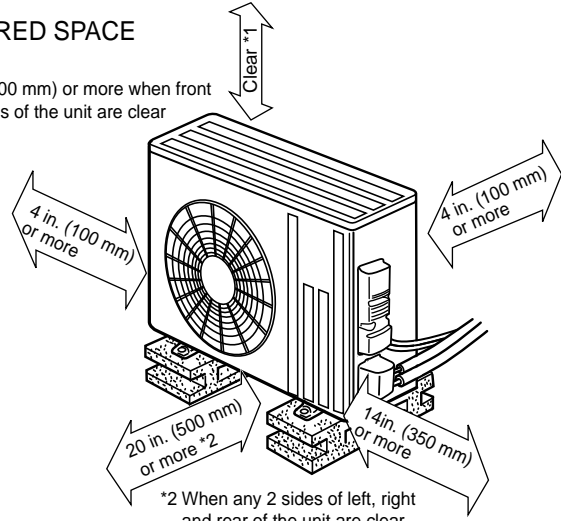
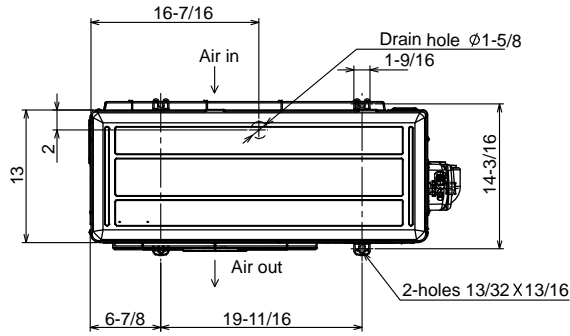

MUZ-FH09NA MUZ-FH12NA

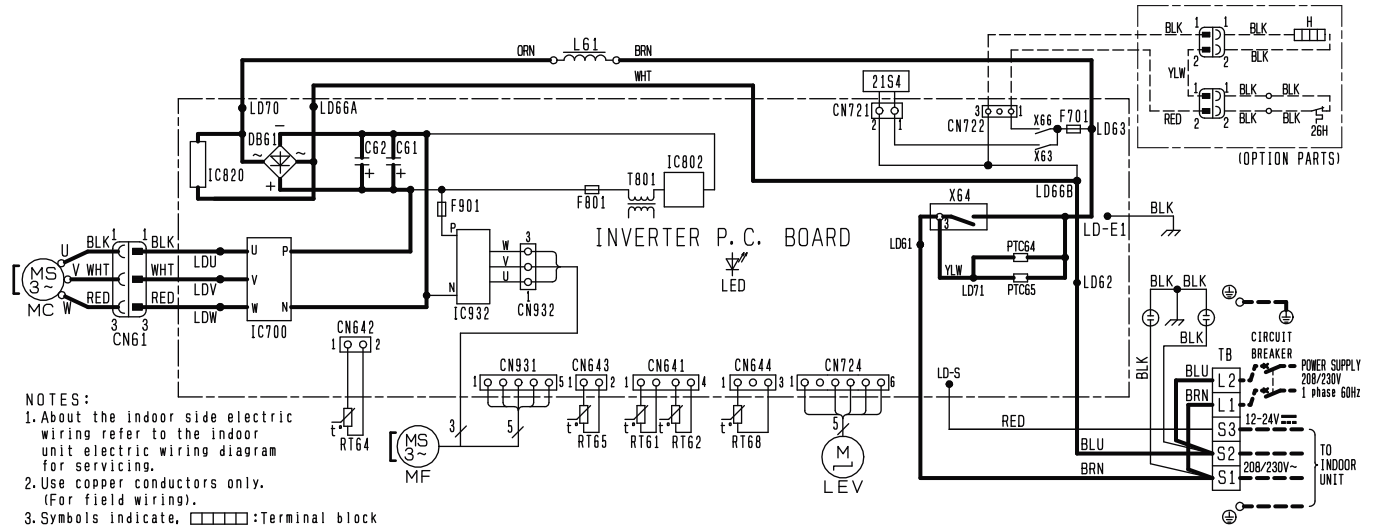

| SYMBOL | NAME | SYMBOL | NAME | SYMBOL | NAME |
|---------------------|-------------------------------|--------------|----------------------------|---------------|--|
| C61, C62 | SMOOTHING CAPACITOR | L61 | REACTOR | RT68 | OUTDOOR HEAT EXCHANGER TEMP. THERMISTOR. |
| DB61 | DIODE MODULE | MC | COMPRESSOR | TB | TERMINAL BLOCK |
| F701, F801, F901 | FUSE (T3. 15A/250V) | MF | FAN MOTOR | T801 | TRANSFORMER |
| H | DEFROST HEATER (OPTION PARTS) | PTC64, PTC65 | CIRCUIT PROTECTION | X63, X64, X66 | RELAY |
| IC700, IC820, IC932 | POWER MODULE | RT61 | DEFROST THERMISTOR | 21S4 | REVERSING VALVE COIL |
| IC802 | POWER DEVICE | RT62 | DISCHARGE TEMP. THERMISTOR | 26H | HEATER PROTECTOR (OPTION PARTS) |
| LED | LED | RT64 | FIN TEMP. THERMISTOR | | |
| LEV | EXPANSION VALVE COIL | RT65 | AMBIENT TEMP. THERMISTOR | | |

MUZ-FH09NAH MUZ-FH12NAH

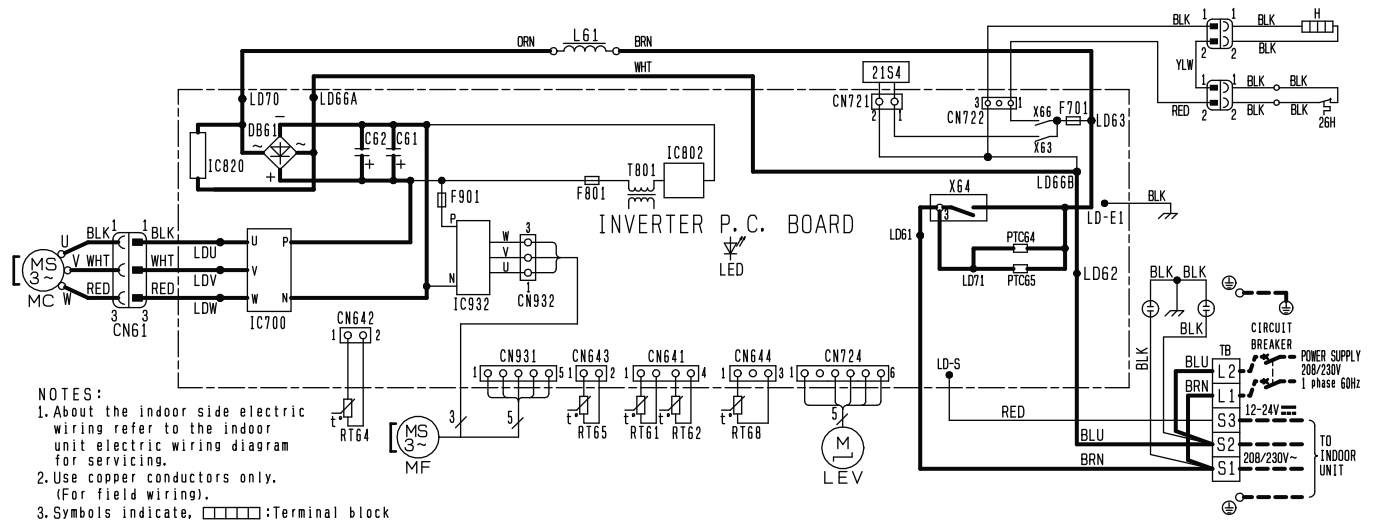

| SYMBOL | NAME | SYMBOL | NAME | SYMBOL | NAME |
|---------------------|----------------------|--------------|----------------------------|---------------|--|
| C61, C62 | SMOOTHING CAPACITOR | L61 | REACTOR | RT68 | OUTDOOR HEAT EXCHANGER TEMP. THERMISTOR. |
| DB61 | DIODE MODULE | MC | COMPRESSOR | TB | TERMINAL BLOCK |
| F701, F801, F901 | FUSE (T3. 15A/250V) | MF | FAN MOTOR | T801 | TRANSFORMER |
| H | DEFROST HEATER | PTC64, PTC65 | CIRCUIT PROTECTION | X63, X64, X66 | RELAY |
| IC700, IC820, IC932 | POWER MODULE | RT61 | DEFROST THERMISTOR | 21S4 | REVERSING VALVE COIL |
| IC802 | POWER DEVICE | RT62 | DISCHARGE TEMP. THERMISTOR | 26H | HEATER PROTECTOR |
| LED | LED | RT64 | FIN TEMP. THERMISTOR | | |
| LEV | EXPANSION VALVE COIL | RT65 | AMBIENT TEMP. THERMISTOR | | |

MUZ-FH15NA

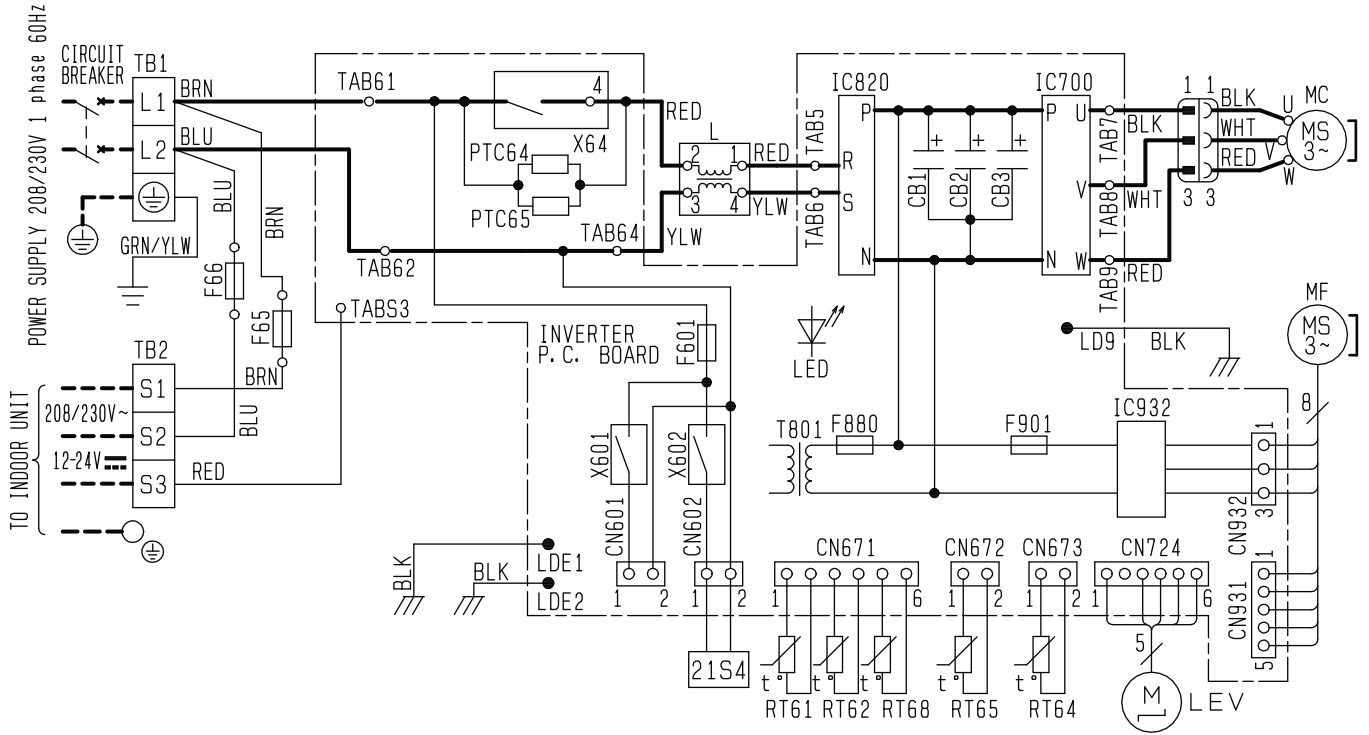

| SYMBOL | NAME | SYMBOL | NAME | SYMBOL | NAME | SYMBOL | NAME |
|----------|---------------------|--------|----------------------|--------|---|----------|----------------------|
| CB1~3 | SMOOTHING CAPACITOR | IC932 | IGBT Module | PTC65 | CIRCUIT PROTECTION | TB1, TB2 | TERMINAL BLOCK |
| F65, F66 | FUSE (T6. 3AL250V) | L | REACTOR | RT61 | DEFROST THERMISTOR | T801 | TRANSFORMER |
| F601 | FUSE (T3. 15AL250V) | LED | LED | RT62 | DISCHARGE TEMP. THERMISTOR | X601 | RELAY |
| F880 | FUSE (T3. 15AL250V) | LEV | EXPANSION VALVE COIL | RT64 | FIN TEMP. THERMISTOR | X602 | RELAY |
| F901 | FUSE (T3. 15AL250V) | MC | COMPRESSOR | RT65 | AMBIENT TEMP. THERMISTOR | X64 | RELAY |
| IC700 | IGBT Module | MF | FAN MOTOR | RT68 | OUTDOOR HEAT EXCHANGER TEMP. THERMISTOR | 21S4 | REVERSING VALVE COIL |
| IC820 | DIODE Module | PTC64 | CIRCUIT PROTECTION | | | | |

NOTES 1. About the indoor side electric wiring, refer to the indoor unit electric wiring diagram for servicing.
 2. Use copper conductors only (for field wiring). 3. Symbols indicate, : Terminal block

MUZ-FH15NAH

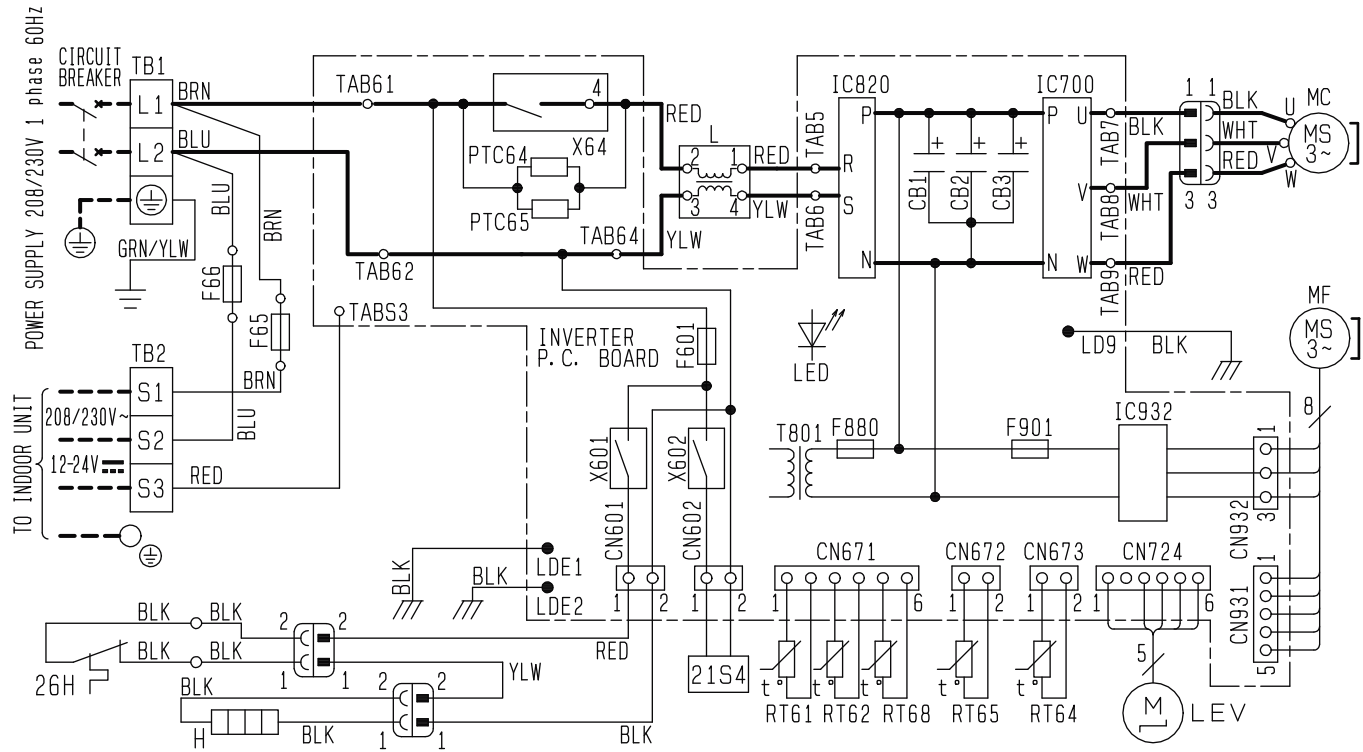

| SYMBOL | NAME | SYMBOL | NAME | SYMBOL | NAME | SYMBOL | NAME |
|----------|----------------------|--------|----------------------|----------|---|--------|----------------------|
| CB1~3 | SMOOTHING CAPACITOR | IC932 | IGBT Module | RT61 | DEFROST THERMISTOR | X601 | RELAY |
| F65, F66 | FUSE (T6. 3AL 250V) | L | REACTOR | RT62 | DISCHARGE TEMP. THERMISTOR | X602 | RELAY |
| F601 | FUSE (T3. 15AL 250V) | LED | LED | RT64 | FIN TEMP. THERMISTOR | X64 | RELAY |
| F880 | FUSE (T3. 15AL 250V) | LEV | EXPANSION VALVE COIL | RT65 | AMBIENT TEMP. THERMISTOR | 21S4 | REVERSING VALVE COIL |
| F901 | FUSE (T3. 15AL 250V) | MC | COMPRESSOR | RT68 | OUTDOOR HEAT EXCHANGER TEMP. THERMISTOR | 26H | HEATER PROTECTOR |
| H | DEFROST HEATER | MF | FAN MOTOR | | | | |
| IC700 | IGBT Module | PTC64 | CIRCUIT PROTECTION | TB1, TB2 | TERMINAL BLOCK | | |
| IC820 | DIODE Module | PTC65 | CIRCUIT PROTECTION | T801 | TRANSFORMER | | |

NOTES 1. About the indoor side electric wiring, refer to the indoor unit electric wiring diagram for servicing.
 2. Use copper conductors only (for field wiring). 3. Symbols indicate, : Terminal block

6

REFRIGERANT SYSTEM DIAGRAM

MUZ-FH09NA MUZ-FH09NAH MUZ-FH12NA MUZ-FH12NAH

Unit: inch

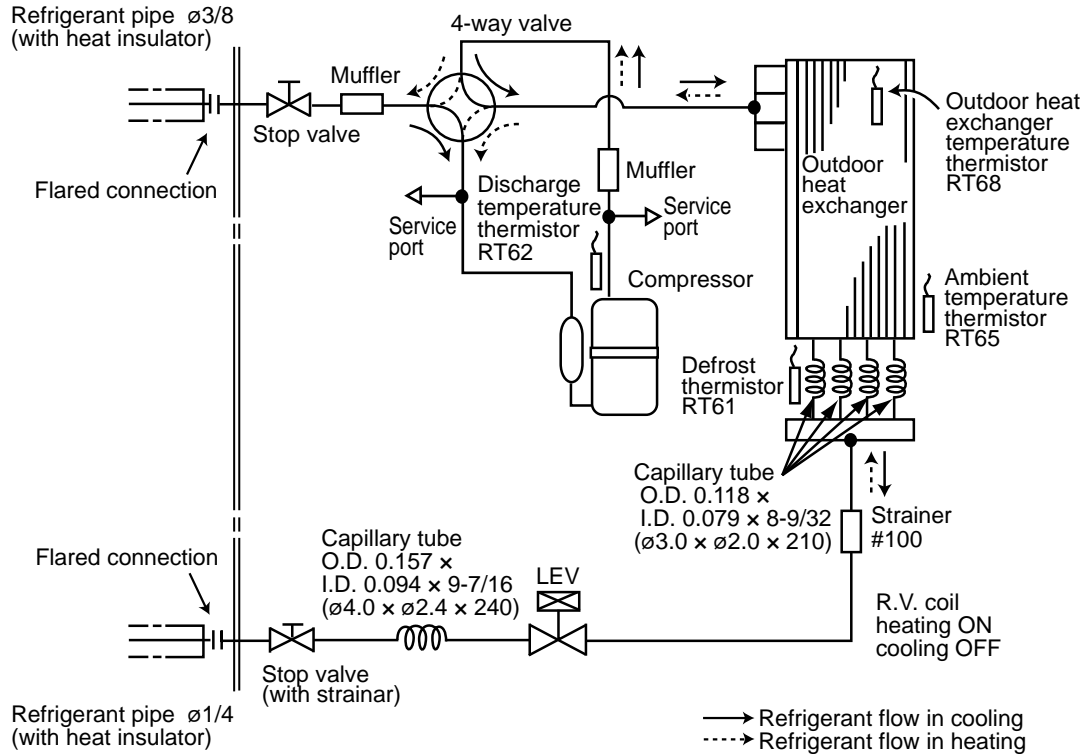

MUZ-FH15NA MUZ-FH15NAH

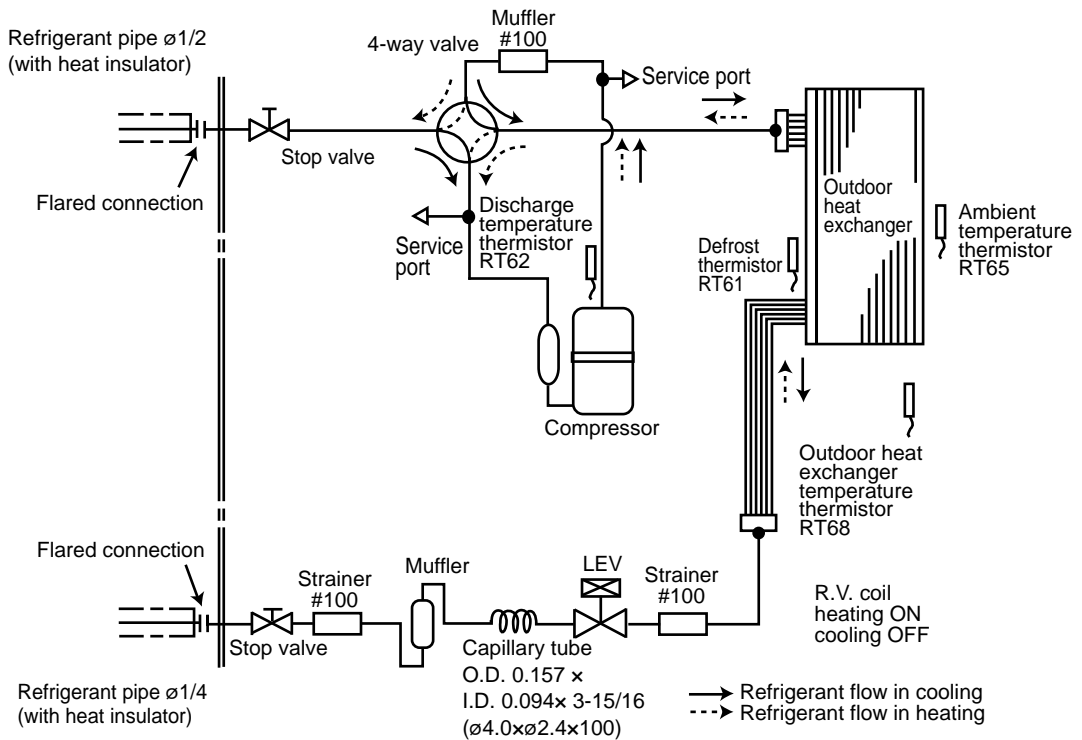

MAX. REFRIGERANT PIPING LENGTH and MAX. HEIGHT DIFFERENCE

| Model | Refrigerant piping: ft. | | Piping size O.D: in. | |
|--|-------------------------|-----------------------------|----------------------|--------|
| | Max. Length A | Max. Height difference B | Gas | Liquid |
| MUZ-FH09NA MUZ-FH09NAH MUZ-FH12NA MUZ-FH12NAH | 65 | 40 | 3/8 | 1/4 |
| MUZ-FH15NA MUZ-FH15NAH | 100 | 50 | 1/2 | 1/4 |

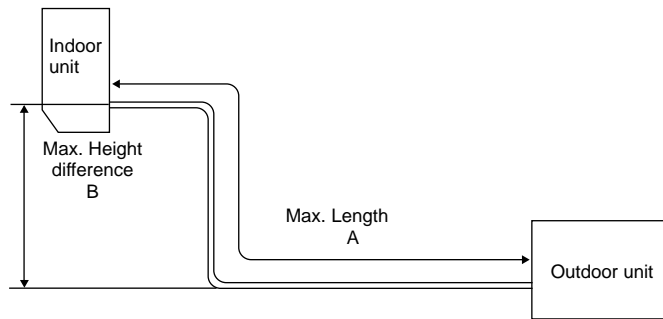

ADDITIONAL REFRIGERANT CHARGE (R410A: oz.)

NOTE: Refrigerant piping exceeding 25 ft. requires additional refrigerant charge according to the calculation.

| Model | Outdoor unit precharged | Refrigerant piping length (one way): ft. | | | | | |
|---------------------------|----------------------------|--|------|------|------|------|------|
| | | 25 | 30 | 40 | 50 | 60 | 65 |
| MUZ-FH09NA MUZ-FH09NAH | 2 lb. 9 oz. | 0 | 1.08 | 3.24 | 5.40 | 7.56 | 8.64 |

Calculation: X oz. = 1.08/5 oz./ft. × (Refrigerant piping length (ft.) - 25)

NOTE: Refrigerant piping exceeding 25 ft. requires additional refrigerant charge according to the calculation.

| Model | Outdoor unit precharged | Refrigerant piping length (one way): ft. | | | | | |
|---------------------------|----------------------------|--|------|------|------|-------|-------|
| | | 25 | 30 | 40 | 50 | 60 | 65 |
| MUZ-FH12NA MUZ-FH12NAH | 2 lb. 9 oz. | 0 | 1.62 | 4.86 | 8.10 | 11.34 | 12.96 |

Calculation: X oz. = 1.62/5 oz./ft. × (Refrigerant piping length (ft.) - 25)

NOTE: Refrigerant piping exceeding 25 ft. requires additional refrigerant charge according to the calculation.

| Model | Outdoor unit precharged | Refrigerant piping length (one way): ft. | | | | | | | | |
|---------------------------|----------------------------|--|------|------|------|------|------|-------|-------|-------|
| | | 25 | 30 | 40 | 50 | 60 | 70 | 80 | 90 | 100 |
| MUZ-FH15NA MUZ-FH15NAH | 3 lb. 7 oz. | 0 | 1.08 | 3.24 | 5.40 | 7.56 | 9.72 | 11.88 | 14.04 | 16.20 |

Calculation: X oz. = 1.08/5 oz./ft. × (Refrigerant piping length (ft.) - 25)

MUZ-FH09NA MUZ-FH09NAH MUZ-FH12NA MUZ-FH12NAH MUZ-FH15NA MUZ-FH15NAH
7-1. PERFORMANCE DATA
1) COOLING CAPACITY

| Model | Indoor air | Outdoor intake air DB temperature (°F) | | | | | | | | | | | | | | |
|---------------------------|------------|--|------|------|------|------|------|------|------|------|------|------|------|------|-----|------|
| | IWB (°F) | 75 | | | 85 | | | 95 | | | 105 | | | 115 | | |
| | | TC | SHC | TPC | TC | SHC | TPC | TC | SHC | TPC | TC | SHC | TPC | TC | SHC | TPC |
| MUZ-FH09NA MUZ-FH09NAH | 71 | 11.0 | 8.7 | 0.50 | 10.3 | 8.1 | 0.55 | 9.7 | 7.6 | 0.59 | 9.0 | 7.1 | 0.62 | 8.3 | 6.5 | 0.64 |
| | 67 | 10.4 | 9.6 | 0.47 | 9.7 | 8.9 | 0.52 | 9.0 | 8.3 | 0.56 | 8.4 | 7.7 | 0.59 | 7.7 | 7.1 | 0.62 |
| | 63 | 9.8 | 10.3 | 0.45 | 9.1 | 9.6 | 0.50 | 8.5 | 8.9 | 0.53 | 7.7 | 8.1 | 0.57 | 7.0 | 7.4 | 0.59 |
| MUZ-FH12NA MUZ-FH12NAH | 71 | 14.7 | 10.2 | 0.77 | 13.7 | 9.6 | 0.85 | 12.9 | 9.0 | 0.91 | 12.0 | 8.4 | 0.96 | 11.0 | 7.7 | 1.00 |
| | 67 | 13.9 | 11.6 | 0.73 | 13.0 | 10.8 | 0.80 | 12.0 | 10.0 | 0.87 | 11.2 | 9.3 | 0.92 | 10.3 | 8.5 | 0.97 |
| | 63 | 13.1 | 12.6 | 0.70 | 12.1 | 11.7 | 0.77 | 11.3 | 10.9 | 0.83 | 10.3 | 9.9 | 0.89 | 9.4 | 9.0 | 0.92 |
| MUZ-FH15NA MUZ-FH15NAH | 71 | 18.4 | 10.4 | 1.07 | 17.2 | 9.7 | 1.17 | 16.1 | 9.1 | 1.26 | 15.0 | 8.5 | 1.33 | 13.8 | 7.8 | 1.38 |
| | 67 | 17.4 | 12.2 | 1.01 | 16.2 | 11.3 | 1.11 | 15.0 | 10.5 | 1.20 | 14.0 | 9.8 | 1.27 | 12.8 | 9.0 | 1.33 |
| | 63 | 16.4 | 13.6 | 0.96 | 15.2 | 12.6 | 1.06 | 14.1 | 11.8 | 1.15 | 12.8 | 10.7 | 1.22 | 11.7 | 9.8 | 1.27 |

NOTE: 1. IWB : Intake air wet-bulb temperature TC : Total Capacity ($\times 10^3$ Btu/h)
 SHC : Sensible Heat Capacity ($\times 10^3$ Btu/h) TPC : Total Power Consumption (kW)
 2. SHC is based on 80°F of indoor Intake air DB temperature.

2) COOLING CAPACITY CORRECTIONS

| | Refrigerant piping length (one way: ft.) | | | |
|--|--|-------|-------|-------|
| | 25 (std.) | 40 | 65 | 100 |
| MUZ-FH09NA MUZ-FH09NAH MUZ-FH12NA MUZ-FH12NAH | 1.0 | 0.954 | 0.878 | - |
| MUZ-FH15NA MUZ-FH15NAH | 1.0 | 0.954 | 0.878 | 0.771 |

3) HEATING CAPACITY

| Model | Indoor air IDB (°F) | Outdoor intake air WB temperature (°F) | | | | | | | | | | | | | |
|-------------|------------------------|--|------|------|------|------|------|------|------|------|------|------|------|------|------|
| | | 5 | | 15 | | 25 | | 35 | | 43 | | 45 | | 55 | |
| | | TC | TPC | TC | TPC | TC | TPC | TC | TPC | TC | TPC | TC | TPC | TC | TPC |
| MUZ-FH09NA | 75 | 4.8 | 0.42 | 6.3 | 0.53 | 7.9 | 0.62 | 9.4 | 0.69 | 10.6 | 0.73 | 11.0 | 0.74 | 12.4 | 0.77 |
| | 70 | 5.2 | 0.40 | 6.7 | 0.51 | 8.2 | 0.61 | 9.6 | 0.67 | 10.9 | 0.71 | 11.2 | 0.72 | 12.7 | 0.75 |
| | 65 | 5.5 | 0.38 | 6.9 | 0.49 | 8.6 | 0.59 | 10.0 | 0.66 | 11.2 | 0.69 | 11.6 | 0.70 | 13.0 | 0.74 |
| MUZ-FH09NAH | 75 | 4.8 | 0.55 | 6.3 | 0.66 | 7.9 | 0.75 | 9.4 | 0.69 | 10.6 | 0.73 | 11.0 | 0.74 | 12.4 | 0.77 |
| | 70 | 5.2 | 0.53 | 6.7 | 0.64 | 8.2 | 0.74 | 9.6 | 0.67 | 10.9 | 0.71 | 11.2 | 0.72 | 12.7 | 0.75 |
| | 65 | 5.5 | 0.51 | 6.9 | 0.62 | 8.6 | 0.72 | 10.0 | 0.66 | 11.2 | 0.69 | 11.6 | 0.70 | 13.0 | 0.74 |
| MUZ-FH12NA | 75 | 6.0 | 0.56 | 7.9 | 0.71 | 9.9 | 0.83 | 11.8 | 0.93 | 13.3 | 0.97 | 13.7 | 0.99 | 15.5 | 1.03 |
| | 70 | 6.5 | 0.54 | 8.4 | 0.68 | 10.2 | 0.81 | 12.0 | 0.90 | 13.6 | 0.95 | 14.0 | 0.97 | 15.8 | 1.01 |
| | 65 | 6.8 | 0.51 | 8.6 | 0.66 | 10.7 | 0.78 | 12.4 | 0.88 | 14.0 | 0.93 | 14.4 | 0.94 | 16.2 | 0.99 |
| MUZ-FH12NAH | 75 | 6.0 | 0.69 | 7.9 | 0.84 | 9.9 | 0.96 | 11.8 | 0.93 | 13.3 | 0.97 | 13.7 | 0.99 | 15.5 | 1.03 |
| | 70 | 6.5 | 0.67 | 8.4 | 0.81 | 10.2 | 0.94 | 12.0 | 0.90 | 13.6 | 0.95 | 14.0 | 0.97 | 15.8 | 1.01 |
| | 65 | 6.8 | 0.64 | 8.6 | 0.79 | 10.7 | 0.91 | 12.4 | 0.88 | 14.0 | 0.93 | 14.4 | 0.94 | 16.2 | 0.99 |
| MUZ-FH15NA | 75 | 7.9 | 0.77 | 10.4 | 0.97 | 13.1 | 1.14 | 15.6 | 1.27 | 17.6 | 1.33 | 18.1 | 1.35 | 20.5 | 1.40 |
| | 70 | 8.6 | 0.73 | 11.1 | 0.94 | 13.5 | 1.11 | 15.9 | 1.24 | 18.0 | 1.30 | 18.5 | 1.33 | 21.0 | 1.38 |
| | 65 | 9.0 | 0.70 | 11.3 | 0.90 | 14.1 | 1.07 | 16.5 | 1.20 | 18.5 | 1.27 | 19.1 | 1.29 | 21.4 | 1.35 |
| MUZ-FH15NAH | 75 | 7.9 | 0.90 | 10.4 | 1.10 | 13.1 | 1.27 | 15.6 | 1.27 | 17.6 | 1.33 | 18.1 | 1.35 | 20.5 | 1.40 |
| | 70 | 8.6 | 0.86 | 11.1 | 1.07 | 13.5 | 1.24 | 15.9 | 1.24 | 18.0 | 1.30 | 18.5 | 1.33 | 21.0 | 1.38 |
| | 65 | 9.0 | 0.83 | 11.3 | 1.03 | 14.1 | 1.20 | 16.5 | 1.20 | 18.5 | 1.27 | 19.1 | 1.29 | 21.4 | 1.35 |

NOTE: 1. IDB : Intake air dry-bulb temperature

TC : Total Capacity (x10³ Btu/h)

TPC : Total Power Consumption (kW)

2. Above data is for heating operation without any frost.

How to operate with fixed operational frequency of the compressor.

1. Press the EMERGENCY OPERATION switch on the front of the indoor unit, and select either EMERGENCY COOL mode or EMERGENCY HEAT mode before starting to operate the air conditioner.
2. The compressor starts with operational frequency.
3. The fan speed of the indoor unit is High.
4. This operation continues for 30 minutes.
5. In order to release this operation, press the EMERGENCY OPERATION switch twice or once, or press any button on the remote controller.

7-2. PERFORMANCE CURVE Cooling

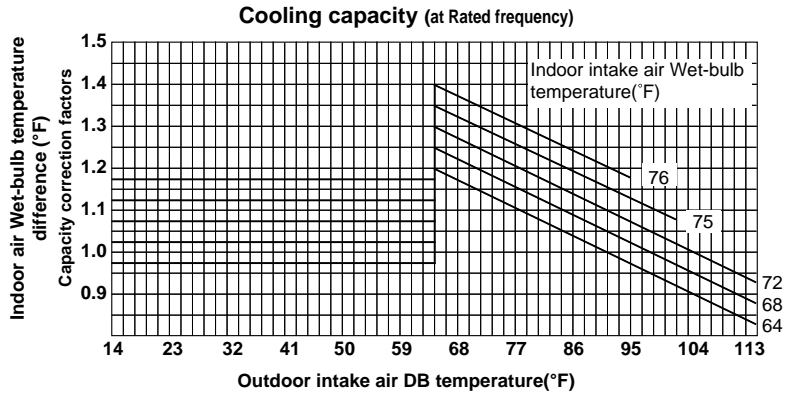

MUZ-FH09NA MUZ-FH09NAH

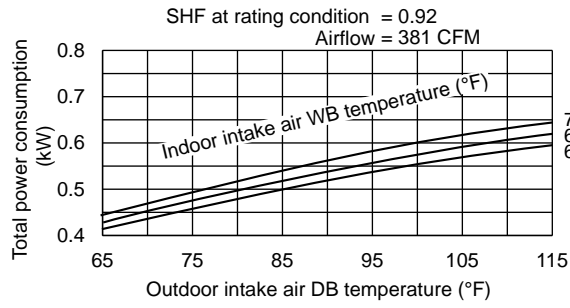

MUZ-FH12NA MUZ-FH12NAH

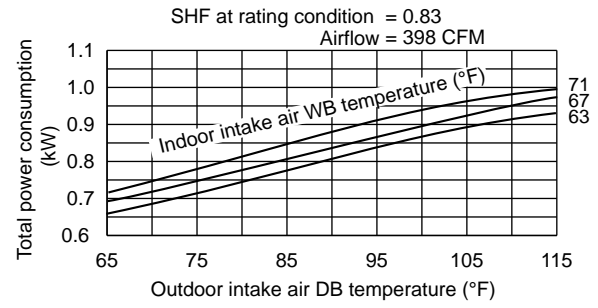

MUZ-FH15NA MUZ-FH15NAH

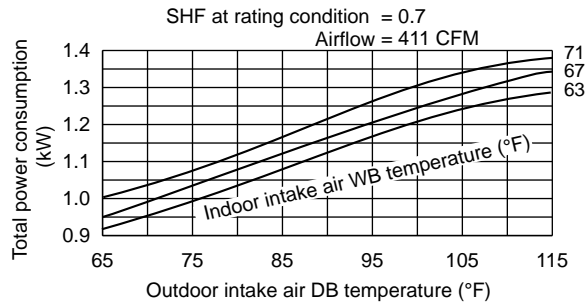

This value of frequency is not the same as the actual frequency in operating. Refer to 7-5 and 7-6 for the relationships between frequency and capacity.

Heating

Heating capacity (at Rated frequency)

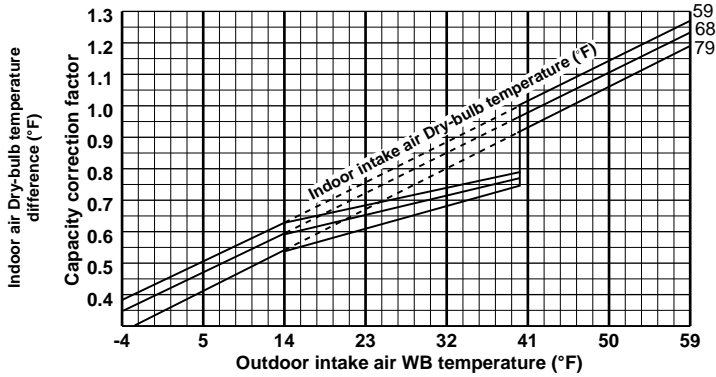

MUZ-FH09NA

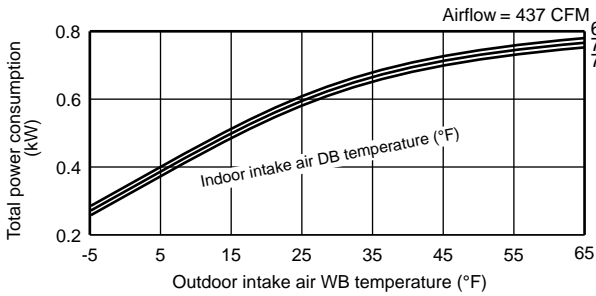

MUZ-FH09NAH

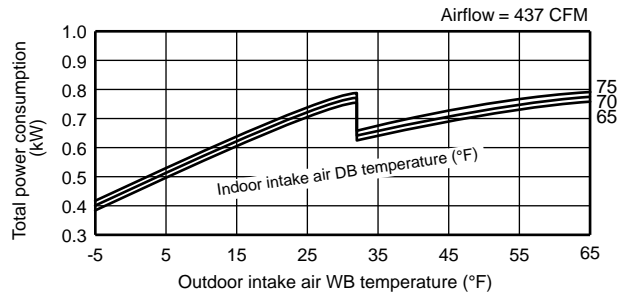

MUZ-FH12NA

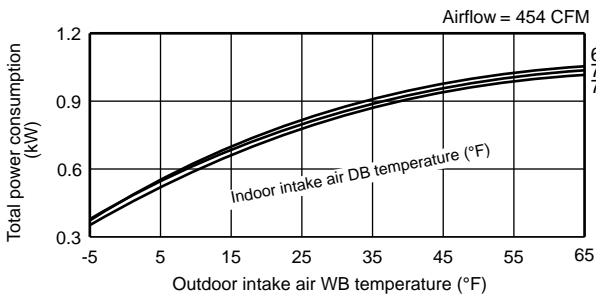

MUZ-FH12NAH

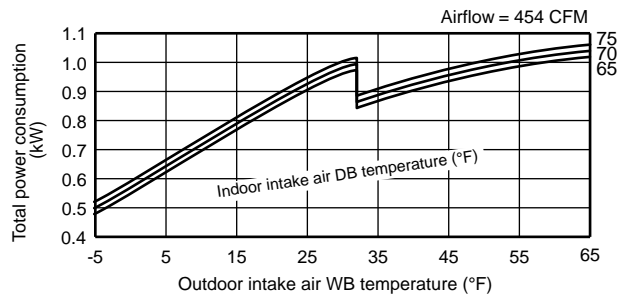

MUZ-FH15NA

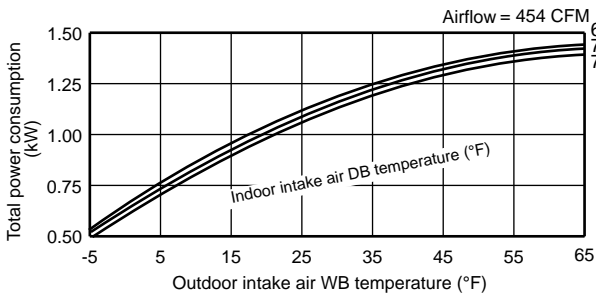

MUZ-FH15NAH

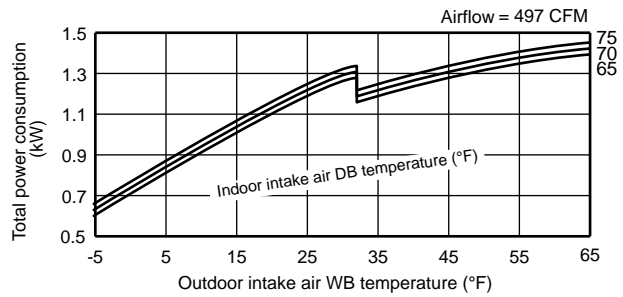

This value of frequency is not the same as the actual frequency in operating. Refer to 7-5 and 7-6 for the relationships between frequency and capacity.

7-3. CONDENSING PRESSURE

Cooling

Data are based on the condition of indoor humidity 50 %.

Air flow should be set to High speed.

MUZ-FH09NA MUZ-FH09NAH

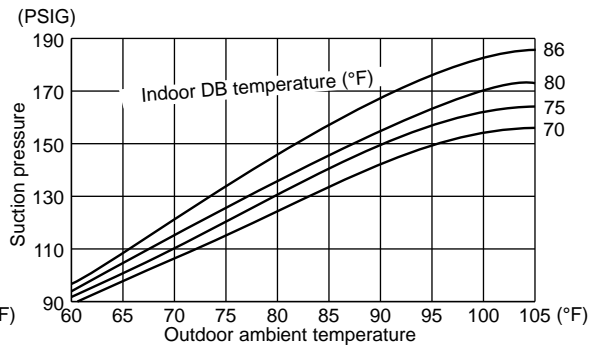
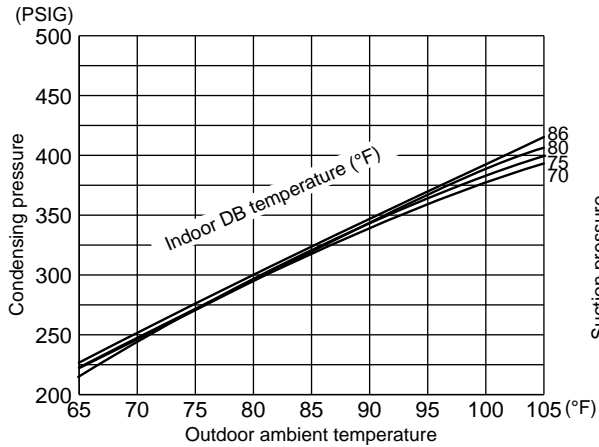

MUZ-FH12NA MUZ-FH12NAH

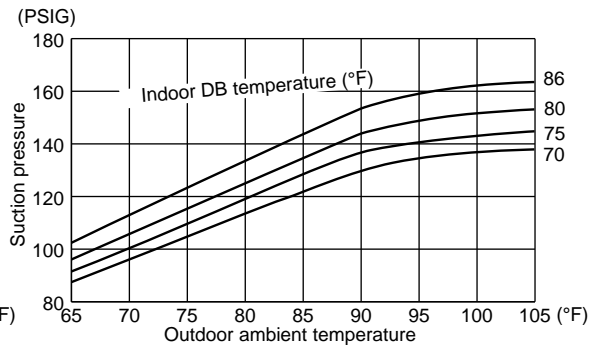
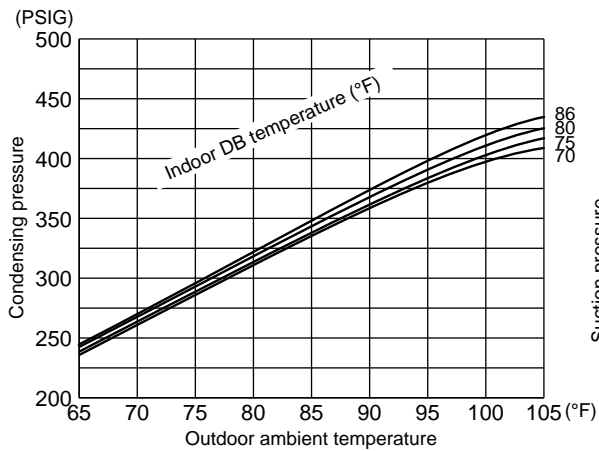

MUZ-FH15NA MUZ-FH15NAH

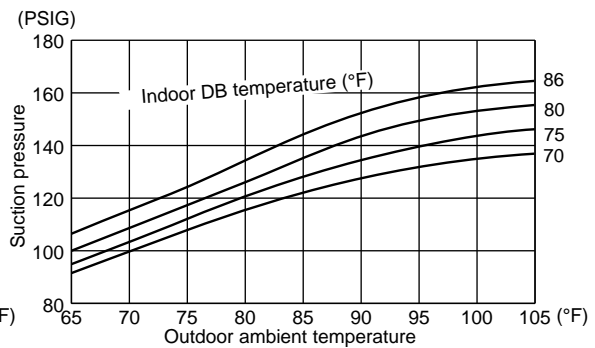
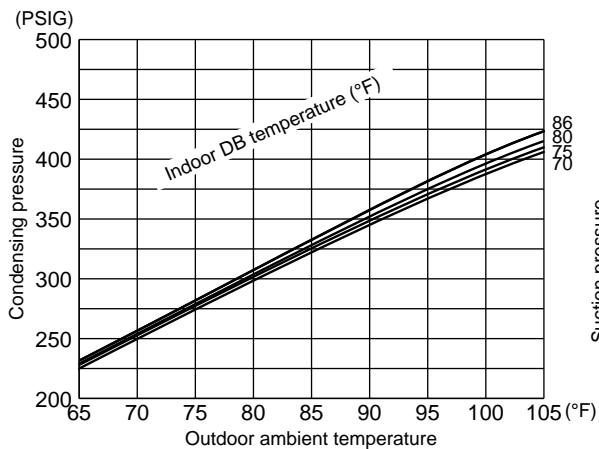

Heating

Data are based on the condition of outdoor humidity 75%.

Air flow should be set to High speed.

Data are for heating operation without any frost.

MUZ-FH09NA MUZ-FH09NAH

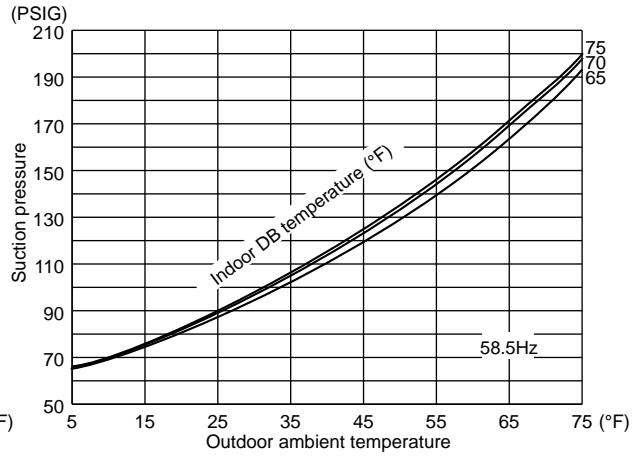
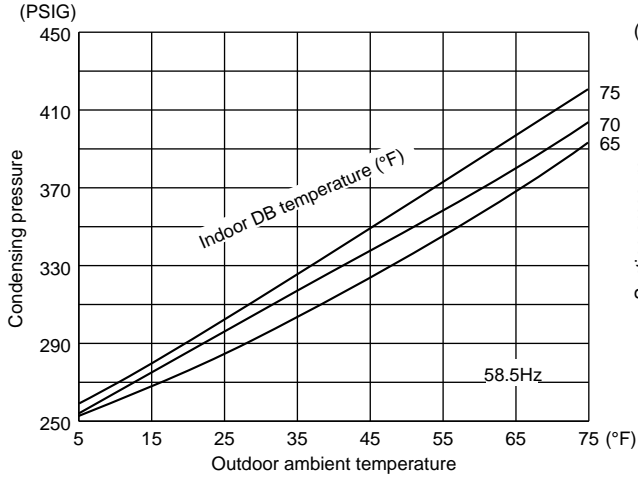

MUZ-FH12NA MUZ-FH12NAH

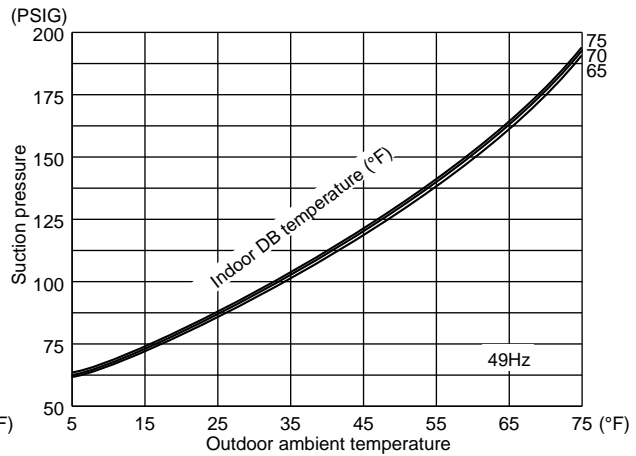
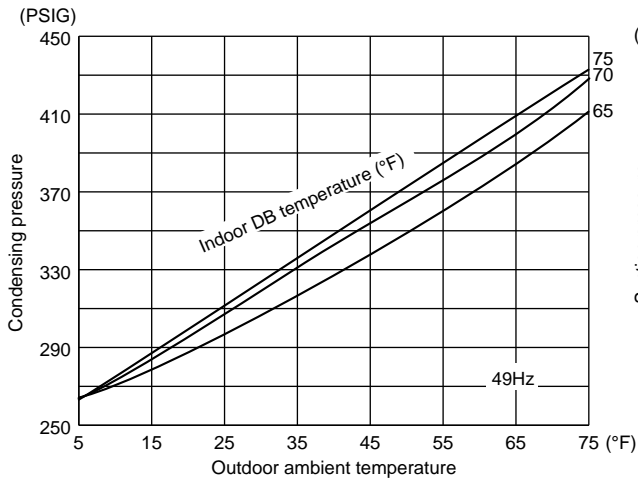

MUZ-FH15NA MUZ-FH15NAH

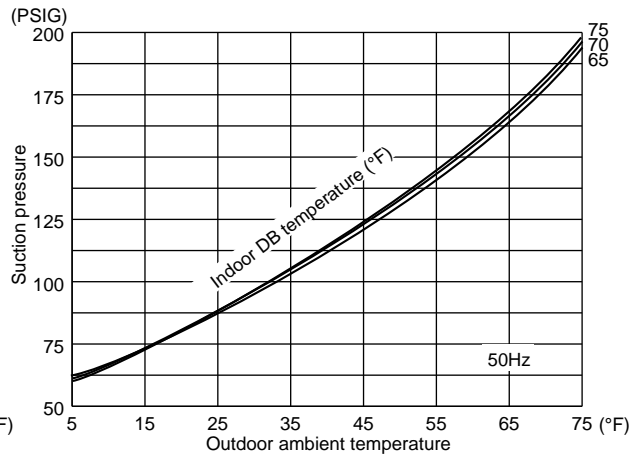
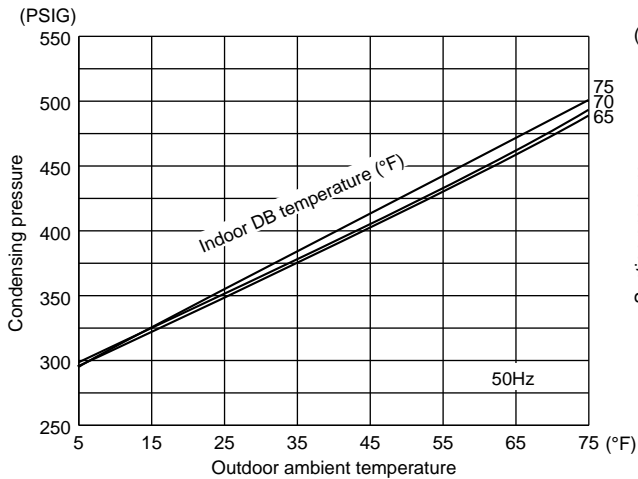

7-4. STANDARD OPERATION DATA

| Model | | | MSZ-FH09NA | | MSZ-FH12NA | | MSZ-FH15NA | | |
|--------------------------------|---------------------------|---------------------|---------------------------|-----------|---------------------------|-----------|---------------------------|-----------|-----|
| Item | | Unit | Cooling | Heating | Cooling | Heating | Cooling | Heating | |
| Total | Capacity | Btu/h | 9,000 | 10,900 | 12,000 | 13,600 | 15,000 | 18,000 | |
| | SHF | — | 0.92 | — | 0.83 | — | 0.70 | — | |
| | Input | kW | 0.560 | 0.710 | 0.870 | 0.950 | 1.200 | 1.300 | |
| | Rated frequency | Hz | 47 | 58.5 | 46 | 49 | 50.5 | 50 | |
| Electrical circuit | Indoor unit | | MSZ-FH09NA | | MSZ-FH12NA | | MSZ-FH15NA | | |
| | Power supply | V, phase, Hz | 208/230, 1, 60 | | | | | | |
| | Input | kW | 0.029 | | 0.029 | | 0.031 | | |
| | Fan motor current | A | 0.30/0.27 | | 0.30/0.27 | | 0.31/0.28 | | |
| | Outdoor unit | | MUZ-FH09NA MUZ-FH09NAH | | MUZ-FH12NA MUZ-FH12NAH | | MUZ-FH15NA MUZ-FH15NAH | | |
| | Power supply | V, phase, Hz | 208/230, 1, 60 | | | | | | |
| | Input | kW | 0.531 | 0.681 | 0.841 | 0.921 | 1.169 | 1.269 | |
| | Comp. current | A | 2.32/2.10 | 3.01/2.72 | 3.60/3.26 | 4.06/3.67 | 4.46/4.03 | 4.87/4.40 | |
| | Fan motor current | A | 0.36/0.33 | 0.34/0.31 | 0.41/0.37 | 0.40/0.36 | 1.21/1.09 | 1.24/1.12 | |
| | Refrigerant circuit | Condensing pressure | PSIG | 352 | 323 | 374 | 340 | 361 | 391 |
| Suction pressure | | PSIG | 153 | 110 | 135 | 106 | 131 | 108 | |
| Discharge temperature | | °F | 148 | 145 | 156 | 148 | 152 | 170 | |
| Condensing temperature | | °F | 107 | 101 | 112 | 105 | 109 | 115 | |
| Suction temperature | | °F | 64 | 41 | 56 | 36 | 52 | 45 | |
| Comp. shell bottom temperature | | °F | 129 | 125 | 137 | 128 | 135 | 147 | |
| Ref. pipe length | | ft. | 25 | | | | | | |
| Refrigerant charge (R410A) | | | 2 lb. 9 oz. | | | | 3 lb 7 oz. | | |
| Indoor unit | Intake air temperature | DB | °F | 80 | 70 | 80 | 70 | 80 | 70 |
| | | WB | °F | 67 | 60 | 67 | 60 | 67 | 60 |
| | Discharge air temperature | DB | °F | 58 | 99 | 56 | 101 | 52 | 111 |
| | | WB | °F | 55 | — | 54 | — | 51 | — |
| | Fan speed (High) | rpm | 1,150 | 1,280 | 1,190 | 1,320 | 1,220 | 1,420 | |
| Airflow (High) | CFM | 381 (Wet) | 437 | 398 (Wet) | 454 | 411 (Wet) | 497 | | |
| Outdoor unit | Intake air temperature | DB | °F | 95 | 47 | 95 | 47 | 95 | 47 |
| | | WB | °F | — | 43 | — | 43 | — | 43 |
| | Fan speed | rpm | 810 | 900 | 810 | 900 | 840 | 810 | |
| | Airflow | CFM | 1,074 | 1,202 | 1,074 | 1,202 | 1,692 | 1,634 | |

7-5. CAPACITY AND INPUT CORRECTION BY INVERTER OUTPUT FREQUENCY

MUZ-FH09NA MUZ-FH09NAH

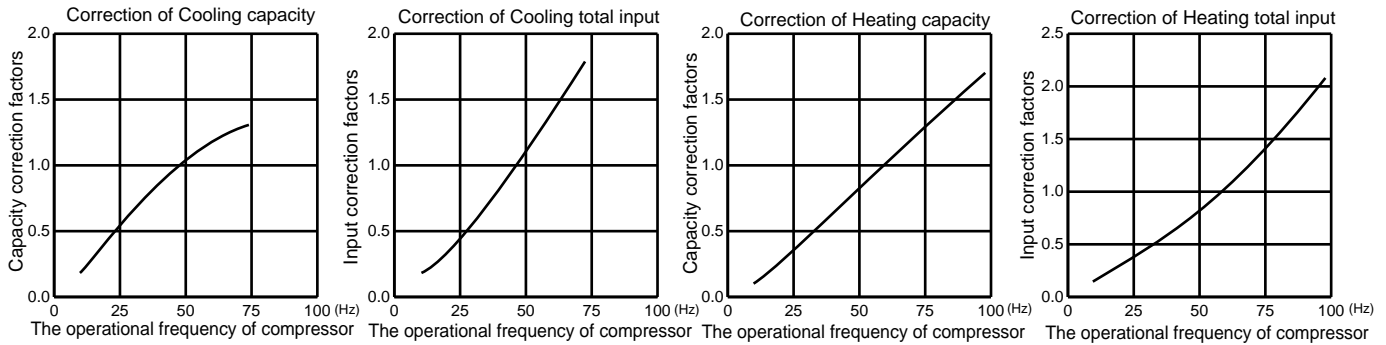

MUZ-FH12NA MUZ-FH12NAH

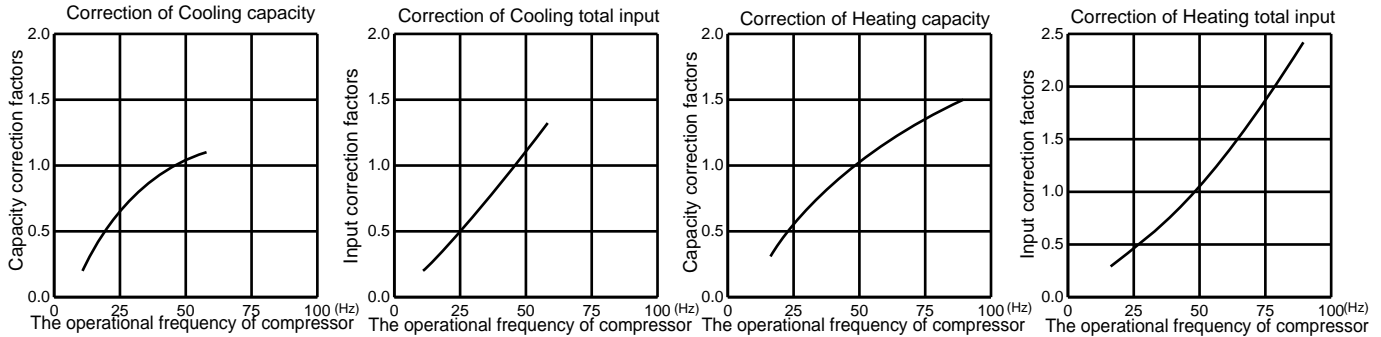

MUZ-FH15NA MUZ-FH15NAH

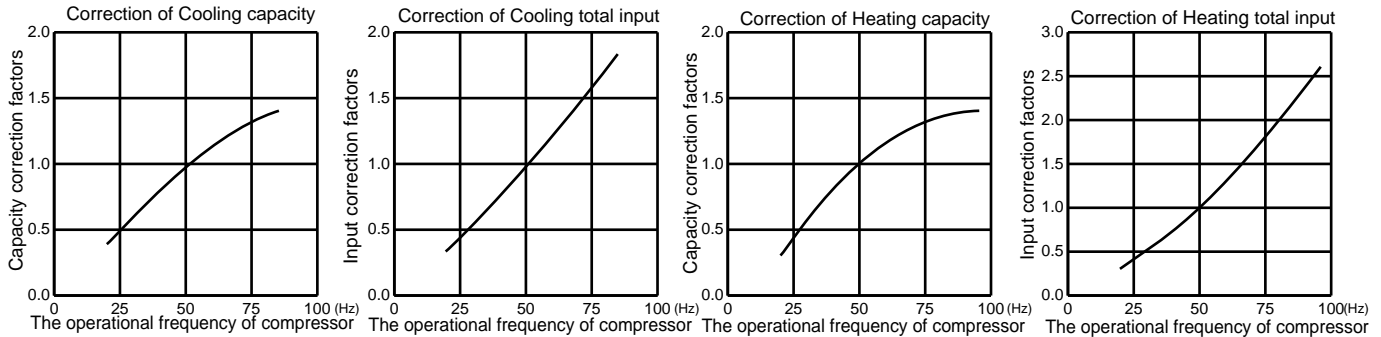

7-6. HOW TO OPERATE FIXED-FREQUENCY OPERATION (Test run operation)

1. Press EMERGENCY OPERATION switch to start COOL or HEAT mode (COOL: Press once, HEAT: Press twice).
2. Test run operation starts and continues to operate for 30 minutes.
3. Compressor operates at rated frequency in COOL mode or 58 Hz in HEAT mode.
4. Indoor fan operates at High speed.
5. After 30 minutes, test run operation finishes and EMERGENCY OPERATION starts (operation frequency of compressor varies).
6. To cancel test run operation (EMERGENCY OPERATION), press EMERGENCY OPERATION switch or any button on remote controller.

8

ACTUATOR CONTROL

MUZ-FH09NA MUZ-FH09NAH MUZ-FH12NA MUZ-FH12NAH MUZ-FH15NA MUZ-FH15NAH

8-1. OUTDOOR FAN MOTOR CONTROL

The fan motor turns ON/OFF, interlocking with the compressor.

[ON] The fan motor turns ON 5 seconds before the compressor starts up.

[OFF] The fan motor turns OFF 15 seconds after the compressor has stopped running.

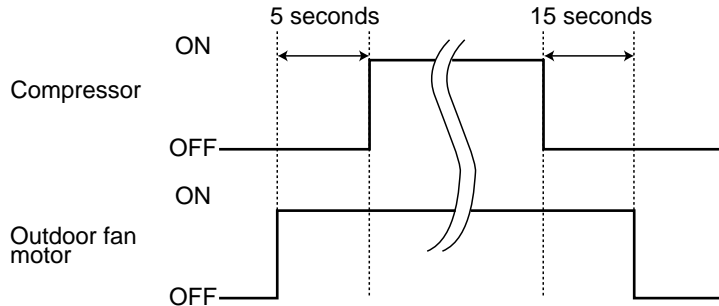

8-2. R.V. COIL CONTROL

Heating ON

Cooling OFF

Dry OFF

NOTE: The 4-way valve reverses for 5 seconds right before start-up of the compressor.

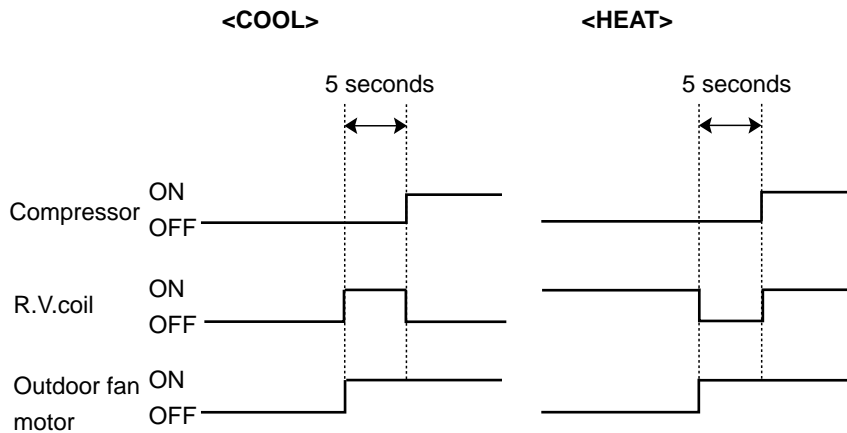

8-3. RELATION BETWEEN MAIN SENSOR AND ACTUATOR

| Sensor | Purpose | Actuator | | | | | |
|---|--|------------|-----|-------------------|----------|------------------|------------------|
| | | Compressor | LEV | Outdoor fan motor | R.V.coil | Indoor fan motor | Defrost heater * |
| Discharge temperature thermistor | Protection | ○ | ○ | | | | |
| Indoor coil temperature thermistor | Cooling: Coil frost prevention | ○ | | | | | |
| | Heating: High pressure protection | ○ | ○ | | | | |
| Defrost thermistor | Heating: Defrosting | ○ | ○ | ○ | ○ | ○ | |
| Fin temperature thermistor | Protection | ○ | | ○ | | | |
| Ambient temperature thermistor | Cooling: Low ambient temperature operation | ○ | ○ | ○ | | | |
| | Heating: Defrosting (Heater) | | | | | | ○ |
| Outdoor heat exchanger temperature thermistor | Cooling: Low ambient temperature operation | ○ | ○ | ○ | | | |
| | Cooling: High pressure protection | ○ | ○ | ○ | | | |

*. MUZ-FH•NAH only.

MUZ-FH09NA MUZ-FH09NAH MUZ-FH12NA MUZ-FH12NAH MUZ-FH15NA MUZ-FH15NAH**9-1. CHANGE IN DEFROST SETTING****Changing defrost finish temperature**

<JS> To change the defrost finish temperature, cut/solder the JS wire of the outdoor inverter P.C. board (Refer to 10-6.1.).

| Jumper | | Defrost finish temperature | |
|--------|-------------------------------|---------------------------------|---------------------------|
| | | MUZ-FH09/12NA MUZ-FH09/12NAH | MUZ-FH15NA MUZ-FH15NAH |
| JS | Soldered (Initial setting) | 41°F (5°C) | 50°F (10°C) |
| | None (Cut) | 50°F (10°C) | 64°F (18°C) |

9-2. PRE-HEAT CONTROL SETTING**MUZ-FH09/12**

When moisture gets into the refrigerant cycle, it may interfere the start-up of the compressor at low outside temperature. The pre-heat control prevents this interference. The pre-heat control turns ON when the discharge temperature thermistor is 68°F (20°C) or below. When the pre-heat control turns ON, the compressor is energized. (About 50 W)

MUZ-FH15

Prolonged low load operation, in which the thermostat is OFF for a long time, at low outside temperature [32°F (0°C) or less] may cause the following troubles. To prevent those troubles, activate the pre-heat control.

- 1) If moisture gets into the refrigerant cycle and freezes, it may interfere the start-up of the compressor.
- 2) If liquid refrigerant collects in the compressor, a failure in the compressor may occur.

The pre-heat control turns ON when the compressor temperature is 68°F (20°C) or below. When the pre-heat control turns ON, the compressor is energized. (About 70 W)

Pre-heat control setting

<JK>

ON: To activate the pre-heat control, cut JK wire of the inverter P.C. board.

OFF: To deactivate the pre-heat control, solder JK wire of the inverter P.C. board.

(Refer to 10-6.1)

NOTE: When the inverter P.C. board is replaced, check the jumper wires, and cut/solder them if necessary.

MUZ-FH09NA MUZ-FH09NAH MUZ-FH12NA MUZ-FH12NAH MUZ-FH15NA MUZ-FH15NAH**10-1. CAUTIONS ON TROUBLESHOOTING****1. Before troubleshooting, check the following**

- 1) Check the power supply voltage.
- 2) Check the indoor/outdoor connecting wire for miswiring.

2. Take care of the following during servicing

- 1) Before servicing the air conditioner, be sure to turn OFF the main unit first with the remote controller, then after confirming the horizontal vane is closed, turn off the breaker and/or disconnect the power plug.
- 2) Be sure to turn OFF the power supply before removing the front panel, the cabinet, the top panel, and the electronic control P.C. board.
- 3) When removing the electrical parts, be careful of the residual voltage of smoothing capacitor.
- 4) When removing the electronic control P.C. board, hold the edge of the board with care NOT to apply stress on the components.
- 5) When connecting or disconnecting the connectors, hold the housing of the connector. DO NOT pull the lead wires.

<Incorrect>

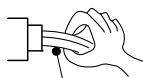
**Lead wiring**

<Correct>

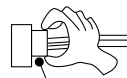
**Housing point****3. Troubleshooting procedure**

- 1) Check if the OPERATION INDICATOR lamp on the indoor unit is flashing on and off to indicate an abnormality. To make sure, check how many times the OPERATION INDICATOR lamp is flashing on and off before starting service work.
- 2) Before servicing, check that the connector and terminal are connected properly.
- 3) When the electronic control P.C. board seems to be defective, check the copper foil pattern for disconnection and the components for bursting and discoloration.
- 4) Refer to 10-2 and 10-3.

10-2. FAILURE MODE RECALL FUNCTION

Outline of the function

This air conditioner can memorize the abnormal condition which has occurred once.

Even though LED indication listed on the troubleshooting check table (10-3.) disappears, the memorized failure details can be recalled.

1. Flow chart of failure mode recall function for the indoor/outdoor unit

Operational procedure

The cause of abnormality cannot be found because the abnormality does not recur.

Setting up the failure mode recall function

Turn ON the power supply.
 <Preparation of the remote controller>
 ① While pressing OPERATION SELECT button and TEMP \oplus button on the remote controller at the same time, press RESET button.
 ② First, release RESET button.
 Hold down the other two buttons for another 3 seconds. Make sure that the indicators on the LCD screen shown in the right figure are all displayed. Then release the buttons.

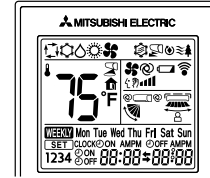
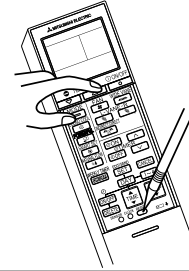

Press OPERATE/STOP (ON/OFF) button of the remote controller (the set temperature is displayed) with the remote controller headed towards the indoor unit. ※1

※1. Regardless of normal or abnormal condition, a short beep is emitted once the signal is received.

Does the left lamp of the OPERATION INDICATOR lamp on the indoor unit blink at the interval of 0.5 seconds?
 Blinks: Either indoor or outdoor unit is abnormal. Beep is emitted at the same timing as the blinking of the left lamp of the OPERATION INDICATOR lamp. ※2

Indoor unit is normal.
 But the outdoor unit might be abnormal because there are some abnormalities that can not be recalled with this way.
 Check if outdoor unit is abnormal according to the detailed outdoor unit failure mode recall function. (Refer to 10-2.2)

Judgment of indoor/outdoor abnormality

Before blinking, does the left lamp of the OPERATION INDICATOR lamp stay ON for 3 seconds?
 Stays ON for 3 seconds (without beep): The outdoor unit is abnormal.

The indoor unit is abnormal.
 Check the blinking pattern, and identify the abnormal point by referring to the indoor unit failure mode table. (Refer to indoor unit service manual.)
 Make sure to check at least two consecutive blinking cycles. ※2

The outdoor unit is abnormal.
 Check the blinking pattern, and identify the abnormal point by referring to the outdoor unit failure mode table. (Refer to 10-2.3)
 Make sure to check at least two consecutive blinking cycles. ※3

Releasing the failure mode recall function

Release the failure mode recall function by the following procedures.
 Turn OFF the power supply and turn it ON again.
 Press RESET button of the remote controller.

Repair the failure parts.

Deleting the memorized abnormal condition

① After repairing the unit, recall the failure mode again according to "Setting up the failure mode recall function" mentioned above.
 ② Press OPERATE/STOP (ON/OFF) button of the remote controller (the set temperature is displayed) with the remote controller headed towards the indoor unit.
 ③ Press EMERGENCY OPERATION switch so that the memorized abnormal condition is deleted.
 ④ Release the failure mode recall function according to "Releasing the failure mode recall function" mentioned above.

NOTE: 1. Make sure to release the failure mode recall function after it is set up, otherwise the unit cannot operate properly.
 2. If the abnormal condition is not deleted from the memory, the last abnormal condition is kept memorized.

※2. Blinking pattern when the indoor unit is abnormal:

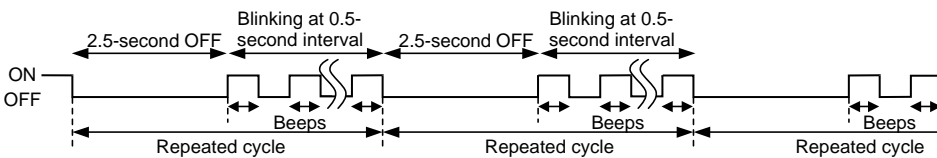

※3. Blinking pattern when the outdoor unit is abnormal:

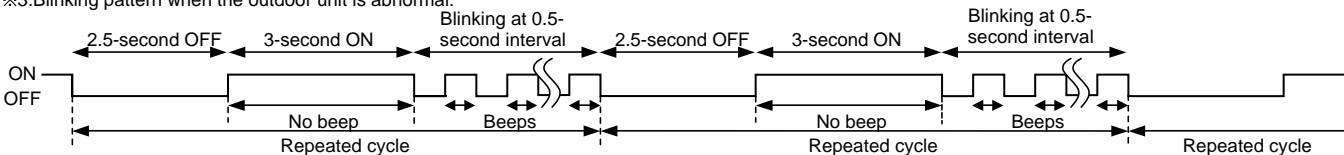

2. Flow chart of the detailed outdoor unit failure mode recall function

Operational procedure

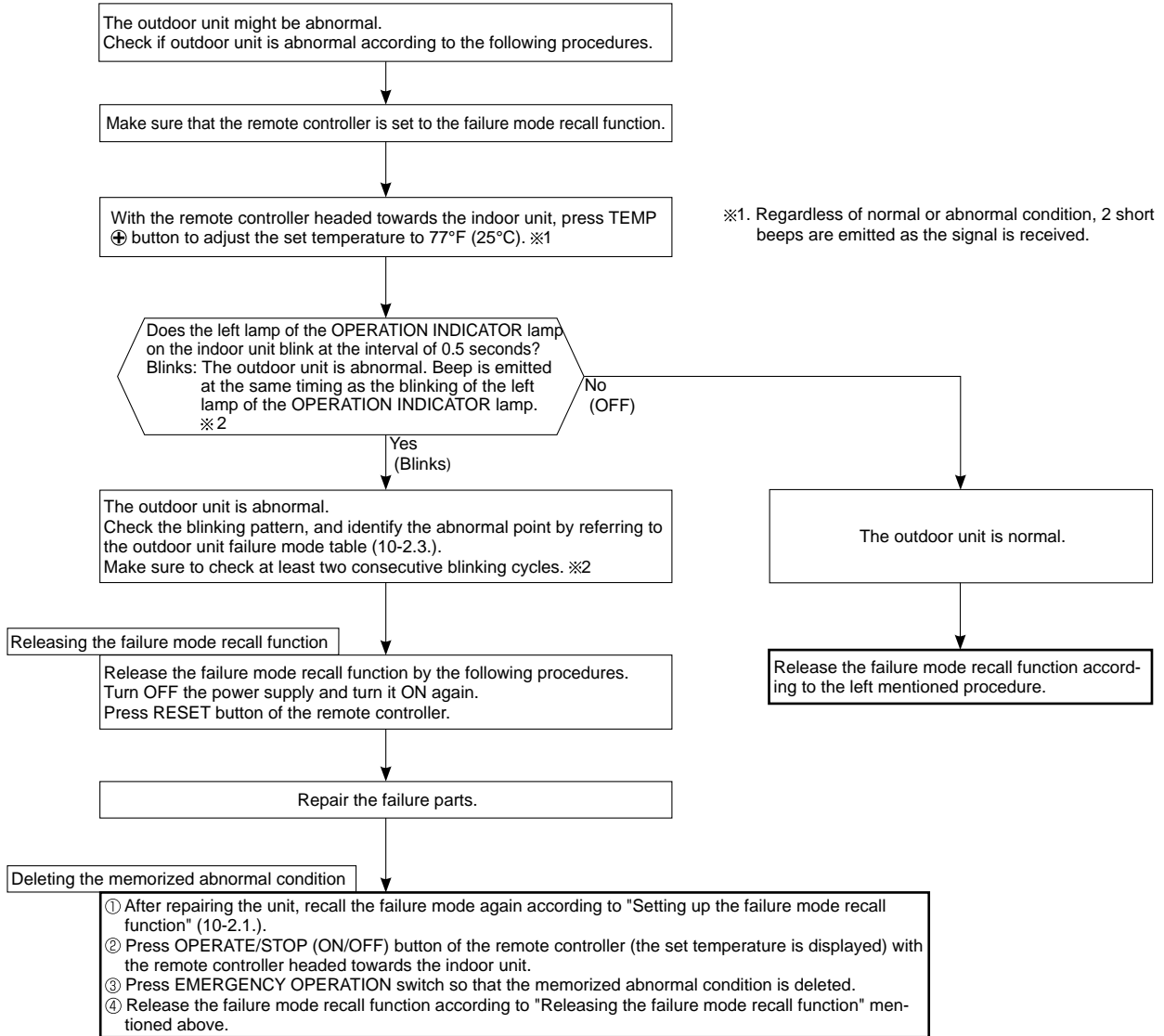

NOTE: 1. Make sure to release the failure mode recall function after it is set up, otherwise the unit cannot operate properly.
2. If the abnormal condition is not deleted from the memory, the last abnormal condition is kept memorized.

※2. Blinking pattern when outdoor unit is abnormal:

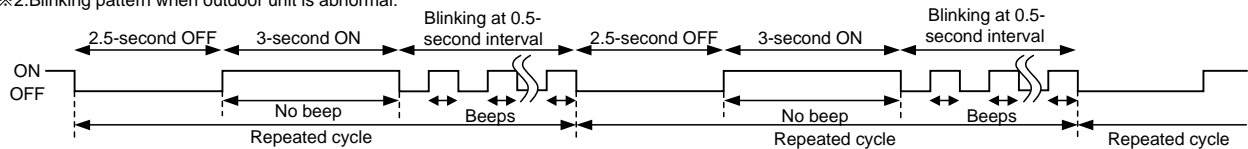

3. Outdoor unit failure mode table

| The left lamp of the OPERATION INDICATOR lamp (Indoor unit) | Abnormal point (Failure mode/protection) | LED indication (Outdoor P.C. board) | Condition | Remedy | Indoor/outdoor unit failure mode recall function | Outdoor unit failure mode recall function |
|---|---|-------------------------------------|--|--|--|---|
| OFF | None (Normal) | — | — | — | — | — |
| 1-time flash 2.5 seconds OFF | Indoor/outdoor communication, receiving error | — | Any signals from the inverter P.C. board cannot be received normally for 3 minutes. | •Refer to 10-5. ㉔ How to check miswiring and serial signal error. | ○ | ○ |
| | Indoor/outdoor communication, receiving error | — | Although the inverter P.C. board sends signal "0", signal "1" has been received 30 consecutive times. | •Refer to 10-5. ㉔ How to check miswiring and serial signal error. | | |
| 2-time flash 2.5 seconds OFF | Outdoor power system | — | Overcurrent protection cut-out operates 3 consecutive times within 1 minute after the compressor gets started. | •Reconnect connectors. •Refer to 10-5. ㉔ How to check inverter/compressor". •Check stop valve. | ○ | ○ |
| 3-time flash 2.5 seconds OFF | Discharge temperature thermistor | 1-time flash every 2.5 seconds | Thermistor shorts or opens during compressor running. | •Refer to 10-5. ㉔ "Check of outdoor thermistors". Defective outdoor thermistors can be identified by checking the blinking pattern of LED. | ○ | ○ |
| | Defrost thermistor | — | | | | |
| | Fin temperature thermistor | 3-time flash 2.5 seconds OFF | | | | |
| | P.C. board temperature thermistor | 4-time flash 2.5 seconds OFF | | | | |
| | Ambient temperature thermistor | 2-time flash 2.5 seconds OFF | | | | |
| | Outdoor heat exchanger temperature thermistor | — | | | | |
| 4-time flash 2.5 seconds OFF | Overcurrent | 11-time flash 2.5 seconds OFF | Large current flows into the power module (IC700) (FH09/12)/ IGBT module (IC700) (FH15). | •Reconnect compressor connector. •Refer to 10-5. ㉔ How to check inverter/compressor". •Check stop valve. | — | ○ |
| | Compressor synchronous abnormality (Compressor start-up failure protection) | 12-time flash 2.5 seconds OFF | Waveform of compressor current is distorted. | •Reconnect compressor connector. •Refer to 10-5. ㉔ How to check inverter/compressor". | — | ○ |
| 5-time flash 2.5 seconds OFF | Discharge temperature | — | Temperature of discharge temperature thermistor exceeds 241°F (116°C), compressor stops. Compressor can restart if discharge temperature thermistor reads 212°F (100°C) or less 3 minutes later. | •Check refrigerant circuit and refrigerant amount. •Refer to 10-5. ㉔ Check of LEV". | — | ○ |
| 6-time flash 2.5 seconds OFF | High pressure | — | Temperature indoor coil thermistor exceeds 158°F (70°C) in HEAT mode. Temperature defrost thermistor exceeds 158°F (70°C) in COOL mode. | •Check refrigerant circuit and refrigerant amount. •Check stop valve. | — | ○ |
| 7-time flash 2.5 seconds OFF | Fin temperature/ P.C. board temperature | 7-time flash 2.5 seconds OFF | Temperature of the fin temperature thermistor on the inverter P.C. board exceeds 167 ~ 187°F (75 ~ 86°C) (FH09/12)/167 ~ 176°F (75 ~ 80°C) (FH15), or temperature of P.C. board temperature thermistor on the inverter P.C. board exceeds 162 ~ 185°F (72 ~ 85°C) (FH09/12)/158 ~ 167°F (70 ~ 75 °C) (FH15). | •Check around outdoor unit. •Check outdoor unit air passage. •Refer to 10-5. ㉔ Check of outdoor fan motor". | — | ○ |
| 8-time flash 2.5 seconds OFF | Outdoor fan motor | — | Outdoor fan has stopped 3 times in a row within 30 seconds after outdoor fan start-up. | •Refer to 10-5. ㉔ Check of outdoor fan motor". Refer to 10-5. ㉔ Check of inverter P.C. board". | — | ○ |
| 9-time flash 2.5 seconds OFF | Nonvolatile memory data | 5-time flash 2.5 seconds OFF | Nonvolatile memory data cannot be read properly. | •Replace the inverter P.C. board. | ○ | ○ |
| | Power module (IC700) (FH09/12) IGBT module (IC700) (FH15) | 6-time flash 2.5 seconds OFF | The interface short circuit occurs in the output of the power module (IC700) (FH09/12)/IGBT module (IC700) (FH15). The compressor winding shorts circuit. | •Refer to 10-5. ㉔ How to check inverter/compressor". | | |

NOTE: Blinking patterns of this mode differ from the ones of TROUBLESHOOTING CHECK TABLE (10-3.).



| The left lamp of the OPERATION INDICATOR lamp (Indoor unit) | Abnormal point (Failure mode/protection) | LED indication (Outdoor P.C. board) | Condition | Remedy | Indoor/outdoor unit failure mode recall function | Outdoor unit failure mode recall function |
|---|--|-------------------------------------|---|---|--|---|
| 10-time flash 2.5 seconds OFF | Discharge temperature | — | Temperature of discharge temperature thermistor has been 122°F (50°C) or less for 20 minutes. | <ul style="list-style-type: none"> Refer to 10-5.Ⓢ"Check of LEV". Check refrigerant circuit and refrigerant amount. | — | ○ |
| 11-time flash 2.5 seconds OFF | DC voltage | 8-time flash 2.5 seconds OFF | DC voltage of inverter cannot be detected normally. | <ul style="list-style-type: none"> Refer to 10-5.ⓐ"How to check inverter/compressor". | — | ○ |
| | Each phase current of compressor | 9-time flash 2.5 seconds OFF | Each phase current of compressor cannot be detected normally. | | | |
| 14-time flash or more 2.5 seconds OFF | Stop valve (Closed valve) | 14-time flash 2.5 seconds OFF | Closed valve is detected by compressor current. | <ul style="list-style-type: none"> Check stop valve. | ○ | ○ |
| | 4-way valve/ Pipe temperature | 16-time flash 2.5 seconds OFF | The 4-way valve does not work properly. The indoor coil thermistor detects an abnormal temperature. | <ul style="list-style-type: none"> Check the 4-way valve. Replace the inverter P.C. board. | | |
| | Outdoor refrigerant system abnormality | 17-time flash 2.5 seconds OFF | A closed valve and air trapped in the refrigerant circuit are detected based on the temperature sensed by the indoor and outdoor thermistors and the current of the compressor. | <ul style="list-style-type: none"> Check for a gas leak in a connecting piping etc. Check the stop valve. Refer to 10-5.Ⓣ"Check of outdoor refrigerant circuit". | | |

NOTE: Blinking patterns of this mode differ from the ones of TROUBLESHOOTING CHECK TABLE (10-3.).

10-3. TROUBLESHOOTING CHECK TABLE

| No. | Symptom | LED indication | Abnormal point/ Condition | Condition | Remedy |
|-----|--|-------------------------------------|--|--|--|
| 1 | Outdoor unit does not operate. | 1-time flash every 2.5 seconds | Outdoor power system | Overcurrent protection cut-out operates 3 consecutive times within 1 minute after the compressor gets started. | <ul style="list-style-type: none"> Reconnect connector of compressor. Refer to 10-5.Ⓐ "How to check inverter/compressor". Check stop valve. |
| 2 | | | Outdoor thermistors | Discharge temperature thermistor, fin temperature thermistor, defrost thermistor, P.C. board temperature thermistor, outdoor heat exchanger temperature thermistor or ambient temperature thermistor shorts or opens during compressor running. | <ul style="list-style-type: none"> Refer to 10-5.Ⓒ "Check of outdoor thermistors". |
| 3 | | | Outdoor control system | Nonvolatile memory data cannot be read properly. (The left lamp of the OPERATION INDICATOR lamp on the indoor unit lights up or flashes 7-time.) | <ul style="list-style-type: none"> Replace inverter P.C. board. |
| 4 | | 6-time flash every 2.5 seconds OFF | Serial signal | The communication fails between the indoor and outdoor unit for 3 minutes. | <ul style="list-style-type: none"> Check connection between the inverter P.C. board and the relay P.C. board. (FH15) Refer to 10-5.Ⓜ "How to check miswiring and serial signal error." |
| 5 | | 11-time flash every 2.5 seconds OFF | Stop valve/ Closed valve | Closed valve is detected by compressor current. | <ul style="list-style-type: none"> Check stop valve. |
| 6 | | 14-time flash every 2.5 seconds OFF | Outdoor unit (Other abnormality) | Outdoor unit is defective. | <ul style="list-style-type: none"> Refer to 10-2.2. "Flow chart of the detailed outdoor unit failure mode recall function". |
| 7 | | 16-time flash every 2.5 seconds OFF | 4-way valve/ Pipe temperature | The 4-way valve does not work properly. The indoor coil thermistor detects an abnormal temperature. | <ul style="list-style-type: none"> Refer to 10-5.Ⓣ "Check of R.V. coil". Replace the inverter P.C. board. |
| 8 | | 17-time flash every 2.5 seconds OFF | Outdoor refrigerant system abnormality | A closed valve and air trapped in the refrigerant circuit are detected based on the temperature sensed by the indoor and outdoor thermistors and the current of the compressor. | <ul style="list-style-type: none"> Check for a gas leak in a connecting piping etc. Check the stop valve. Refer to 10-5.Ⓢ "Check of outdoor refrigerant circuit". |
| 9 | 'Outdoor unit stops and restarts 3 minutes later' is repeated. | 2-time flash every 2.5 seconds OFF | Overcurrent protection | Large current flows into the power module (IC700) (FH09/12)/ IGBT module (IC700) (FH15). | <ul style="list-style-type: none"> Reconnect connector of compressor. Refer to 10-5.Ⓐ "How to check inverter/compressor". Check stop valve. |
| 10 | | 3-time flash every 2.5 seconds OFF | Discharge temperature overheat protection | Temperature of discharge temperature thermistor exceeds 241°F (116°C), compressor stops. Compressor can restart if discharge temperature thermistor reads 212°F (100°C) or less 3 minutes later. | <ul style="list-style-type: none"> Check refrigerant circuit and refrigerant amount. Refer to 10-5.Ⓢ "Check of LEV". |
| 11 | | 4-time flash every 2.5 seconds OFF | Fin temperature /P.C. board temperature thermistor overheat protection | Temperature of the fin temperature thermistor on the heat sink exceeds 167 ~ 187°F (75 ~ 86°C) (FH09/12)/167 ~ 176°F (75 ~ 80°C) (FH15) or temperature of P.C. board temperature thermistor on the inverter P.C. board exceeds 162 ~ 185°F (72 ~ 85°C) (FH09/12)/158 ~ 167°F (70 ~ 75°C) (FH15). | <ul style="list-style-type: none"> Check around outdoor unit. Check outdoor unit air passage. Refer to 10-5.Ⓛ "Check of outdoor fan motor". |
| 12 | | 5-time flash every 2.5 seconds OFF | High pressure protection | Indoor coil thermistor exceeds 158°F (70°C) in HEAT mode. Defrost thermistor exceeds 158°F (70°C) in COOL mode. | <ul style="list-style-type: none"> Check refrigerant circuit and refrigerant amount. Check stop valve. |
| 13 | | 8-time flash every 2.5 seconds OFF | Compressor synchronous abnormality | The waveform of compressor current is distorted. | <ul style="list-style-type: none"> Reconnect connector of compressor. Refer to 10-5.Ⓐ "How to check inverter/compressor". |
| 14 | | 10-time flash every 2.5 seconds OFF | Outdoor fan motor | Outdoor fan has stopped 3 times in a row within 30 seconds after outdoor fan start-up. | <ul style="list-style-type: none"> Refer to 10-5.Ⓛ "Check of outdoor fan motor." Refer to 10-5.Ⓛ "Check of inverter P.C. board." |
| 15 | | 12-time flash every 2.5 seconds OFF | Each phase current of compressor | Each phase current of compressor cannot be detected normally. | <ul style="list-style-type: none"> Refer to 10-5.Ⓐ "How to check inverter/compressor". |
| 16 | | 13-time flash every 2.5 seconds OFF | DC voltage | DC voltage of inverter cannot be detected normally. | <ul style="list-style-type: none"> It occurs with following case. Instantaneous power voltage drop. (Short time power failure) (FH15) Refer to 10-5.Ⓢ "Check of power supply". (FH15) Refer to 10-5.Ⓐ "How to check inverter/compressor". |

NOTE: 1. The location of LED is illustrated at the right figure. Refer to 10-6.1.
2. LED is lighted during normal operation.

The flashing frequency shows the number of times the LED blinks after every 2.5-second OFF.
(Example) When the flashing frequency is "2".

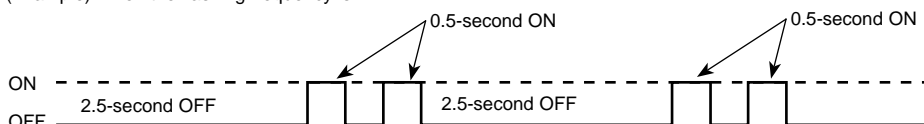

Inverter P.C. board
MUZ-FH09/12NA(H)

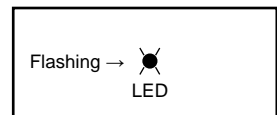

MUZ-FH15NA(H)

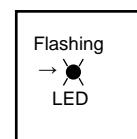



| No. | Symptom | LED indication | Abnormal point/Condition | Condition | | Remedy |
|-----|------------------------|---|---|--|--|--|
| 17 | Outdoor unit operates. | 1-time flash 2.5 seconds OFF | Frequency drop by current protection | FH09/12 | When the input current exceeds approximately 10A (FH09)/10.5A (FH12), compressor frequency lowers. | The unit is normal, but check the following. <ul style="list-style-type: none"> •Check if indoor filters are clogged. •Check if refrigerant is short. •Check if indoor/outdoor unit air circulation is short cycled. |
| | | | | FH15 | Current from power outlet is nearing breaker capacity. | |
| 18 | | 3-time flash 2.5 seconds OFF | Frequency drop by high pressure protection | Temperature of indoor coil thermistor exceeds 131 °F (55°C) in HEAT mode, compressor frequency lowers. | | |
| | | | Frequency drop by defrosting in COOL mode | Indoor coil thermistor reads 46°F (8°C) or less in COOL mode, compressor frequency lowers. | | |
| 19 | | 4-time flash 2.5 seconds OFF | Frequency drop by discharge temperature protection | Temperature of discharge temperature thermistor exceeds 232°F (111°C), compressor frequency lowers. | | <ul style="list-style-type: none"> •Check refrigerant circuit and refrigerant amount. •Refer to 10-5.⊗ "Check of LEV". •Refer to 10-5.⊙ "Check of outdoor thermistors". |
| 20 | | MUZ-FH09/12 5-time flash 2.5 seconds OFF | Outside temperature thermistor protection | When the outside temperature thermistor shorts or opens, protective operation without that thermistor is performed. | | <ul style="list-style-type: none"> •Refer to 10-5. ⊙ Check of outdoor thermistors. |
| 21 | Outdoor unit operates. | 7-time flash 2.5 seconds OFF | Low discharge temperature protection | Temperature of discharge temperature thermistor has been 122°F (50°C) or less for 20 minutes. | | <ul style="list-style-type: none"> •Refer to 10-5.⊗ "Check of LEV". •Check refrigerant circuit and refrigerant amount. |
| 22 | | 8-time flash 2.5 seconds OFF | MUZ-FH09/12 PAM protection PAM: Pulse Amplitude Modulation | The overcurrent flows into PFC (Power factor correction :IC820) or the DC voltage reaches 394 V or more, PAM stops and restarts. | | This is not malfunction. PAM protection will be activated in the following cases: 1 Instantaneous power voltage drop. (Short time power failure) 2 When the power supply voltage is high. •It occurs with following cases. 1 Instantaneous power voltage drop. (Short time power failure) 2 Distortion of primary voltage •Refer to 10-5. ⊙ "Check of power supply". |
| | | | MUZ-FH15 Zero cross detecting circuit | Zero cross signal cannot be detected. | | |
| 23 | | 9-time flash 2.5 seconds OFF | Inverter check mode | The connector of compressor is disconnected, inverter check mode starts. | | <ul style="list-style-type: none"> •Check if the connector of the compressor is correctly connected. Refer to 10-5.Ⓐ "How to check inverter/compressor". |

NOTE: 1. The location of LED is illustrated at the right figure. Refer to 10-6.1.
 2. LED is lighted during normal operation.

The flashing frequency shows the number of times the LED blinks after every 2.5-second OFF.
 (Example) When the flashing frequency is "2".

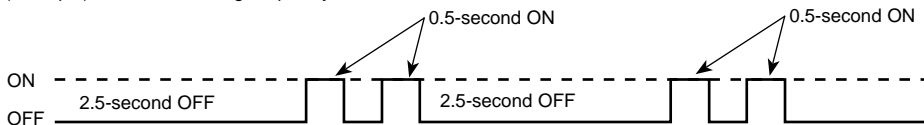

Inverter P.C. board
MUZ-FH09/12NA(H)

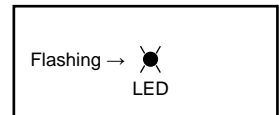

MUZ-FH15NA(H)

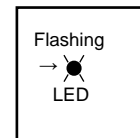

10-4. TROUBLE CRITERION OF MAIN PARTS

**MUZ-FH09NA MUZ-FH09NAH
 MUZ-FH12NA MUZ-FH12NAH
 MUZ-FH15NA MUZ-FH15NAH**

| Part name | Check method and criterion | Figure | | | | | | | | | | | | | | |
|---|---|--------------------|-------------|----------------|-------------|-----------|-----------|-----------|-----------|-----------|-------------|-------------|-------------|-----|-----|--|
| Defrost thermistor (RT61) Fin temperature thermistor (RT64) Ambient temperature thermistor (RT65) Outdoor heat exchanger temperature thermistor (RT68) | Measure the resistance with a tester. Refer to 10-6. "Test point diagram and voltage", 1. "Inverter P.C. board", for the chart of thermistor. | | | | | | | | | | | | | | | |
| Discharge temperature thermistor (RT62) | Measure the resistance with a tester. Before measurement, hold the thermistor with your hands to warm it up. Refer to 10-6. "Test point diagram and voltage", 1. "Inverter P.C. board", for the chart of thermistor. | | | | | | | | | | | | | | | |
| Compressor | Measure the resistance between terminals using a tester. [Temperature: 14 ~ 104°F (-10 ~ 40°C)] <table border="1" style="margin-left: auto; margin-right: auto;"> <thead> <tr> <th></th> <th colspan="3">Normal (Ω)</th> </tr> <tr> <th></th> <th>MUZ-FH09</th> <th>MUZ-FH12</th> <th>MUZ-FH15</th> </tr> </thead> <tbody> <tr> <td>U-V</td> <td rowspan="3">1.60 ~ 2.17</td> <td rowspan="3">1.66 ~ 2.26</td> <td rowspan="3">0.87 ~ 1.18</td> </tr> <tr> <td>U-W</td> </tr> <tr> <td>V-W</td> </tr> </tbody> </table> | | Normal (Ω) | | | | MUZ-FH09 | MUZ-FH12 | MUZ-FH15 | U-V | 1.60 ~ 2.17 | 1.66 ~ 2.26 | 0.87 ~ 1.18 | U-W | V-W | |
| | Normal (Ω) | | | | | | | | | | | | | | | |
| | MUZ-FH09 | MUZ-FH12 | MUZ-FH15 | | | | | | | | | | | | | |
| U-V | 1.60 ~ 2.17 | 1.66 ~ 2.26 | 0.87 ~ 1.18 | | | | | | | | | | | | | |
| U-W | | | | | | | | | | | | | | | | |
| V-W | | | | | | | | | | | | | | | | |
| Outdoor fan motor | Measure the resistance between lead wires using a tester. [Temperature: 14 ~ 104°F (-10 ~ 40°C)] <table border="1" style="margin-left: auto; margin-right: auto;"> <thead> <tr> <th rowspan="2">Color of lead wire</th> <th colspan="2">Normal (Ω)</th> </tr> <tr> <th>MUZ-FH09/12</th> <th>MUZ-FH15</th> </tr> </thead> <tbody> <tr> <td>RED – BLK</td> <td rowspan="3">29 ~ 40</td> <td rowspan="3">12 ~ 16</td> </tr> <tr> <td>BLK – WHT</td> </tr> <tr> <td>WHT – RED</td> </tr> </tbody> </table> | Color of lead wire | Normal (Ω) | | MUZ-FH09/12 | MUZ-FH15 | RED – BLK | 29 ~ 40 | 12 ~ 16 | BLK – WHT | WHT – RED | | | | | |
| Color of lead wire | Normal (Ω) | | | | | | | | | | | | | | | |
| | MUZ-FH09/12 | MUZ-FH15 | | | | | | | | | | | | | | |
| RED – BLK | 29 ~ 40 | 12 ~ 16 | | | | | | | | | | | | | | |
| BLK – WHT | | | | | | | | | | | | | | | | |
| WHT – RED | | | | | | | | | | | | | | | | |
| R. V. coil (21S4) | Measure the resistance using a tester. [Temperature: 14 ~ 104°F (-10 ~ 40°C)] <table border="1" style="margin-left: auto; margin-right: auto;"> <thead> <tr> <th>Normal (kΩ)</th> </tr> </thead> <tbody> <tr> <td>0.97 ~ 1.38</td> </tr> </tbody> </table> | Normal (kΩ) | 0.97 ~ 1.38 | | | | | | | | | | | | | |
| Normal (kΩ) | | | | | | | | | | | | | | | | |
| 0.97 ~ 1.38 | | | | | | | | | | | | | | | | |
| Expansion valve coil (LEV) | Measure the resistance using a tester. [Temperature: 14 ~ 104°F (-10 ~ 40°C)] <table border="1" style="margin-left: auto; margin-right: auto;"> <thead> <tr> <th>Color of lead wire</th> <th>Normal (Ω)</th> </tr> </thead> <tbody> <tr> <td>RED – ORN</td> <td rowspan="5">37 ~ 54</td> </tr> <tr> <td>RED – WHT</td> </tr> <tr> <td>RED – BLU</td> </tr> <tr> <td>RED – YLW</td> </tr> <tr> <td>RED – YLW</td> </tr> </tbody> </table> | Color of lead wire | Normal (Ω) | RED – ORN | 37 ~ 54 | RED – WHT | RED – BLU | RED – YLW | RED – YLW | | | | | | | |
| Color of lead wire | Normal (Ω) | | | | | | | | | | | | | | | |
| RED – ORN | 37 ~ 54 | | | | | | | | | | | | | | | |
| RED – WHT | | | | | | | | | | | | | | | | |
| RED – BLU | | | | | | | | | | | | | | | | |
| RED – YLW | | | | | | | | | | | | | | | | |
| RED – YLW | | | | | | | | | | | | | | | | |
| Defrost heater | Measure the resistance using a tester. [Temperature: 14 ~ 104°F (-10 ~ 40°C)] <table border="1" style="margin-left: auto; margin-right: auto;"> <thead> <tr> <th colspan="2">Normal (Ω)</th> </tr> <tr> <th>MUZ-FH09/12NAH</th> <th>MUZ-FH15NAH</th> </tr> </thead> <tbody> <tr> <td>349 ~ 428</td> <td>376 ~ 461</td> </tr> </tbody> </table> | Normal (Ω) | | MUZ-FH09/12NAH | MUZ-FH15NAH | 349 ~ 428 | 376 ~ 461 | | | | | | | | | |
| Normal (Ω) | | | | | | | | | | | | | | | | |
| MUZ-FH09/12NAH | MUZ-FH15NAH | | | | | | | | | | | | | | | |
| 349 ~ 428 | 376 ~ 461 | | | | | | | | | | | | | | | |

10-5. TROUBLESHOOTING FLOW

Ⓐ How to check inverter/compressor

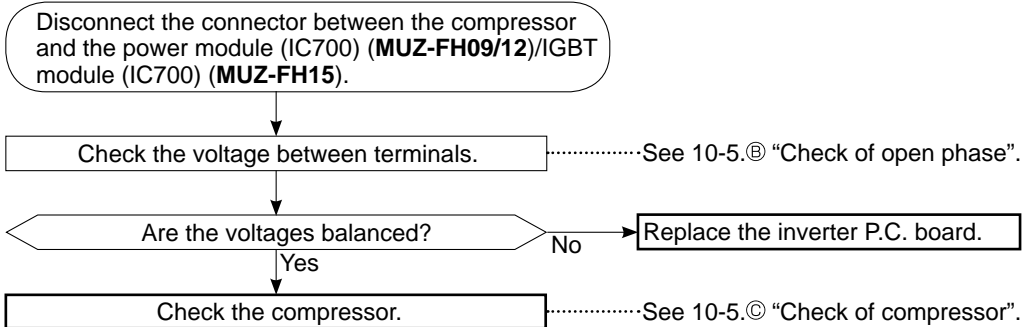

Ⓑ Check of open phase

- With the connector between the compressor and the power module (IC700) (MUZ-FH09/12)/IGBT module (IC700) (MUZ-FH15) disconnected, activate the inverter and check if the inverter is normal by measuring the **voltage balance** between the terminals.

Output voltage is 50 - 130 V. (The voltage may differ according to the tester.)

<< Operation method >>

Start cooling or heating operation by pressing EMERGENCY OPERATION switch on the indoor unit. (TEST RUN OPERATION: Refer to 7-6.)

<< Measurement point >>

At 3 points ※ Measure AC voltage between the lead wires at 3 points.

At 3 points

BLK (U)-WHT (V)

BLK (U)-RED (W)

WHT(V)-RED (W)

NOTE: 1. Output voltage varies according to power supply voltage.

2. Measure the voltage by analog type tester.

3. During this check, LED of the inverter P.C. board flashes 9 times. (Refer to 10-6.1.)

Ⓒ Check of compressor

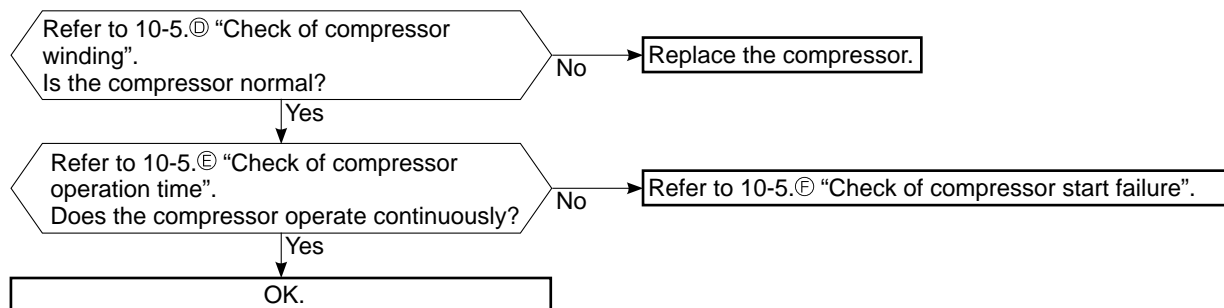

D Check of compressor winding

- Disconnect the connector between the compressor and the power module (IC700) (**MUZ-FH09/12**)/IGBT module (IC700) (**MUZ-FH15**), and measure the resistance between the compressor terminals.

<<Measurement point>>

At 3 points

BLK-WHT

BLK-RED

WHT-RED

※ Measure the resistance between the lead wires at 3 points.

<<Judgement>>

Refer to 10-4.

0 [Ω]Abnormal [short]

Infinite [Ω]Abnormal [open]

NOTE: Be sure to zero the ohmmeter before measurement.

E Check of compressor operation time

- Connect the compressor and activate the inverter. Then measure the time until the inverter stops due to over current.

<<Operation method>>

Start heating or cooling operation by pressing EMERGENCY OPERATION switch on the indoor unit. (TEST RUN OPERATION: Refer to 7-6.)

<<Measurement>>

Measure the time from the start of compressor to the stop of compressor due to overcurrent.

<<Judgement>>

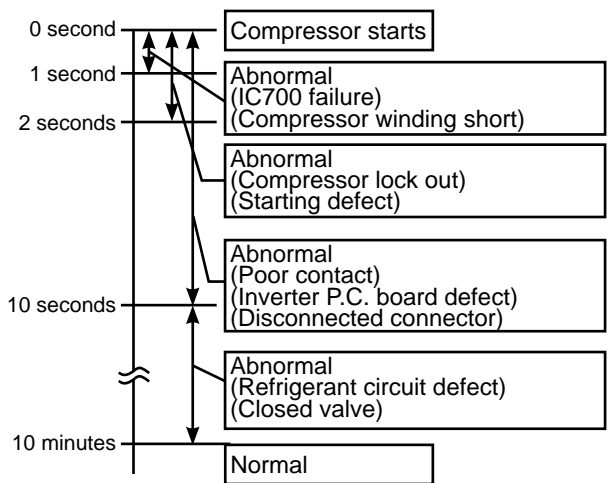

F Check of compressor start failure

Confirm that ①~④ is normal.

- Electrical circuit check

①. Contact of the compressor connector

②. Output voltage of inverter P.C. board and balance of them (See 10-5.③)

③. Direct current voltage between DB61(+) and (-) (**MUZ-FH09/12**)/JP715(+) and JP30(-) (**MUZ-FH15**) on the inverter P.C. board

④. Voltage between outdoor terminal block S1-S2

Does the compressor run for 10 seconds or more after it starts?

Yes

Check the refrigerant circuit.
Check the stop valve.

No

After the compressor is heated with a drier, does the compressor start? ※1

No

Replace the compressor.

Yes

Compressor start failure. Activate pre-heat control.
(Refer to 9-2. "PRE-HEAT CONTROL SETTING")

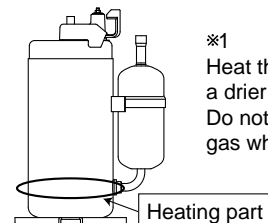

※1

Heat the compressor with a drier for about 20 minutes. Do not recover refrigerant gas while heating.

③ Check of outdoor thermistors

Disconnect the connector of thermistor in the inverter P.C. board (see below table), and measure the resistance of thermistor.

Is the resistance of thermistor normal?
(Refer to 10-6.1.)

No

Replace the thermistor except RT64.
When RT64 is abnormal, replace the inverter P.C. board.

Yes

Reconnect the connector of thermistor.
Turn ON the power supply and press EMERGENCY OPERATION switch.

Does the unit operate for 10 minutes or more
without showing thermistor abnormality?

No

Replace the inverter P.C. board.

Yes

OK.
(Cause is poor contact.)

MUZ-FH09/12

| Thermistor | Symbol | Connector, Pin No. | Board |
|------------------------------------|--------|-----------------------------|---------------------|
| Defrost | RT61 | Between CN641 pin1 and pin2 | Inverter P.C. board |
| Discharge temperature | RT62 | Between CN641 pin3 and pin4 | |
| Fin temperature | RT64 | Between CN642 pin1 and pin2 | |
| Ambient temperature | RT65 | Between CN643 pin1 and pin2 | |
| Outdoor heat exchanger temperature | RT68 | Between CN644 pin1 and pin3 | |

MUZ-FH15

| Thermistor | Symbol | Connector, Pin No. | Board |
|------------------------------------|--------|-----------------------------|---------------------|
| Defrost | RT61 | Between CN671 pin1 and pin2 | Inverter P.C. board |
| Discharge temperature | RT62 | Between CN671 pin3 and pin4 | |
| Fin temperature | RT64 | Between CN673 pin1 and pin2 | |
| Ambient temperature | RT65 | Between CN672 pin1 and pin2 | |
| Outdoor heat exchanger temperature | RT68 | Between CN671 pin5 and pin6 | |

H Check of R.V. coil

MUZ-FH09/12

- ※ First of all, measure the resistance of R.V. coil to check if the coil is defective. Refer to 10-4.
- ※ In case CN721 is disconnected or R.V. coil is open, voltage is generated between the terminal pins of the connector although no signal is being transmitted to R.V. coil.
Check if CN721 is connected.

Unit operates COOL mode even if it is set to HEAT mode.

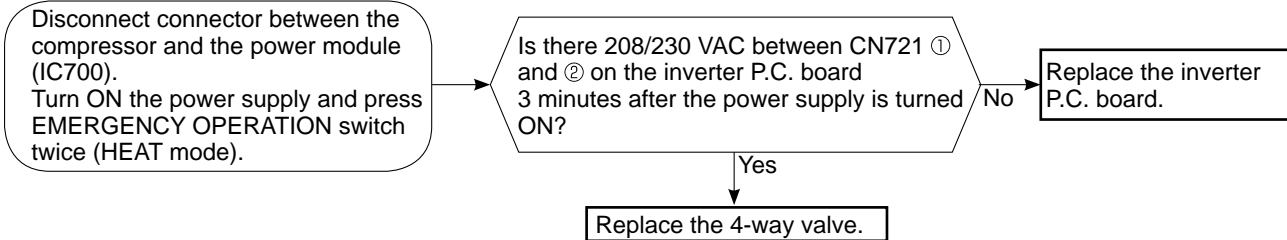

Unit operates HEAT mode even if it is set to COOL mode.

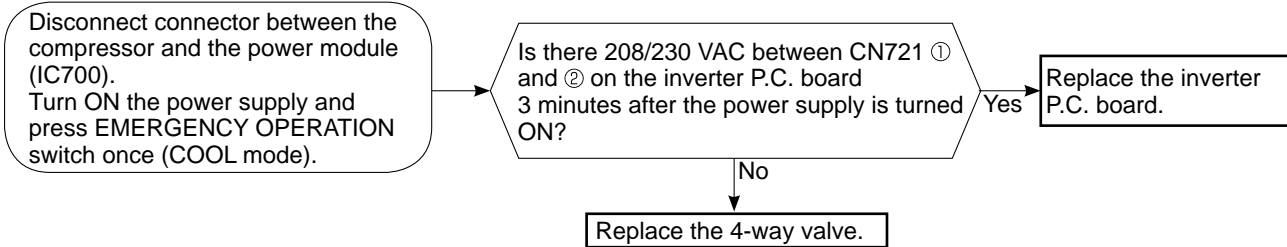

MUZ-FH15

- ※ First of all, measure the resistance of R.V. coil to check if the coil is defective. Refer to 10-4.
- ※ In case CN602 is disconnected or R.V. coil is open, voltage is generated between the terminal pins of the connector although no signal is being transmitted to R.V. coil.
Check if CN602 is connected.

Unit operates COOL mode even if it is set to HEAT mode.

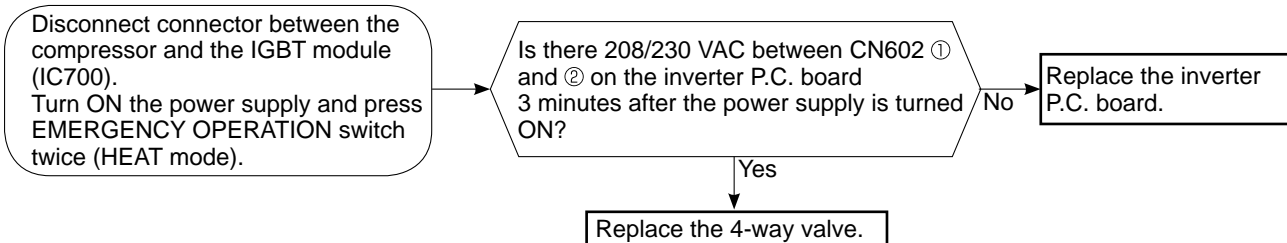

Unit operates HEAT mode even if it is set to COOL mode.

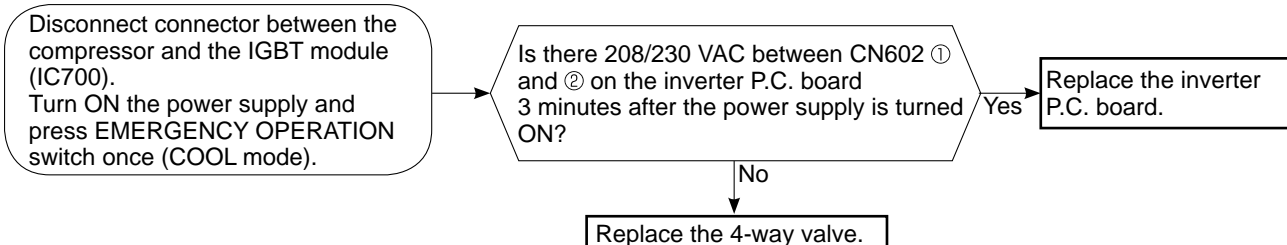

① Check of outdoor fan motor

Disconnect the connectors CN931 and CN932 from the inverter P.C. board.
Check the connection between the connector CN931 and CN932.

Is the resistance between each terminal of outdoor fan motor normal?
(Refer to 10-4.)

Yes

Disconnect CN932 from the inverter P.C. board, and turn on the power supply.

Rotate the outdoor fan motor manually and measure the voltage of CN931.
Between 1(+) and 5(-)
Between 2(+) and 5(-)
Between 3(+) and 5(-)

No

(Fixed to either 5 or 0 VDC)

No

Does the voltage between each terminal become 5 and 0 VDC repeatedly?

Yes

No

Does the outdoor fan motor rotate smoothly?

Yes

Replace the outdoor fan motor.

Replace the inverter P.C. board.

J Check of power supply

Disconnect the connector between the compressor and the power module (IC700) (MUZ-FH09/12)/IGBT module (IC700) (MUZ-FH15). Turn ON power supply and press EMERGENCY OPERATION switch.

Does the left lamp of the OPERATION INDICATOR lamp on the indoor unit light up?

No

Rectify indoor/outdoor connecting wire.

Yes

Is there voltage 208/230 VAC between the indoor terminal block S1 and S2?

No

Replace the indoor electronic control P.C. board.

Yes

Is there DC voltage 260 - 370 VDC between DB61 (+) and DB61 (-) (MUZ-FH09/12)/294 - 370 VDC between JP715 (+) and JP30 (-) (MUZ-FH15) on the inverter P.C. board? (Refer to 10-6.1.)

Yes

Does LED on the inverter P.C. board light up or flash? (Refer to 10-6.1.)

No

Replace the inverter P.C. board.

No

Check the electric parts in main circuit.

If light up, OK.
If flash, refer to 10-3.

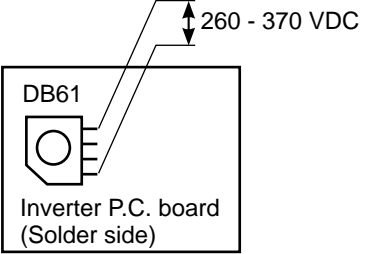

MUZ-FH09/12

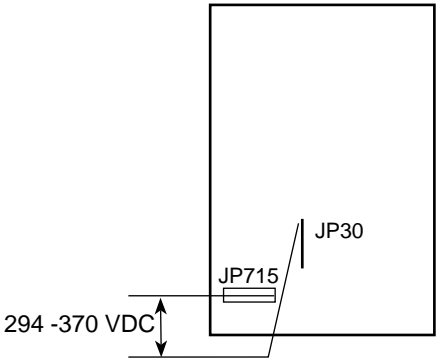

MUZ-FH15

K Check of LEV (Expansion valve)

Turn ON the power supply.

<Preparation of the remote controller>

- ① While pressing both OPERATION SELECT button and TEMP \oplus button on the remote controller at the same time, press RESET button.
- ② First, release RESET button.
Hold down the other two buttons for another 3 seconds. Make sure that the indicators on the LCD screen shown in the right figure are all displayed. Then release the buttons.

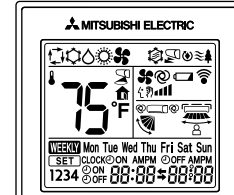
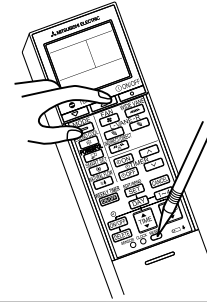

Press OPERATE/STOP (ON/OFF) button of the remote controller (the set temperature is displayed) with the remote controller headed towards the indoor unit. ※1

Expansion valve operates in full-opening direction.

Do you hear the expansion valve "click, click....." ?
Do you feel the expansion valve vibrate on touching it ?

Yes → OK

No

Is LEV coil properly fixed to the expansion valve?

No

Properly fix the LEV coil to the expansion valve.

Yes

Does the resistance of LEV coil have the characteristics? (Refer to 10-4.)

Yes

Measure each voltage between connector pins of CN724 on the inverter P.C. board.

1. Pin③(-) — Pin①(+)
2. Pin④(-) — Pin①(+)
3. Pin⑤(-) — Pin①(+)
4. Pin⑥(-) — Pin①(+)

Is there about 3 - 5 VAC between each?
NOTE: Measure the voltage by an analog tester.

No

Replace the inverter P.C. board.

Replace the LEV coil.

Yes

Replace the expansion valve.

※1. Regardless of normal or abnormal condition, a short beep is emitted once the signal is received.

NOTE: After check of LEV, do the undermentioned operations.

1. Turn OFF the power supply and turn it ON again.
2. Press RESET button on the remote controller.

L Check of inverter P.C. board

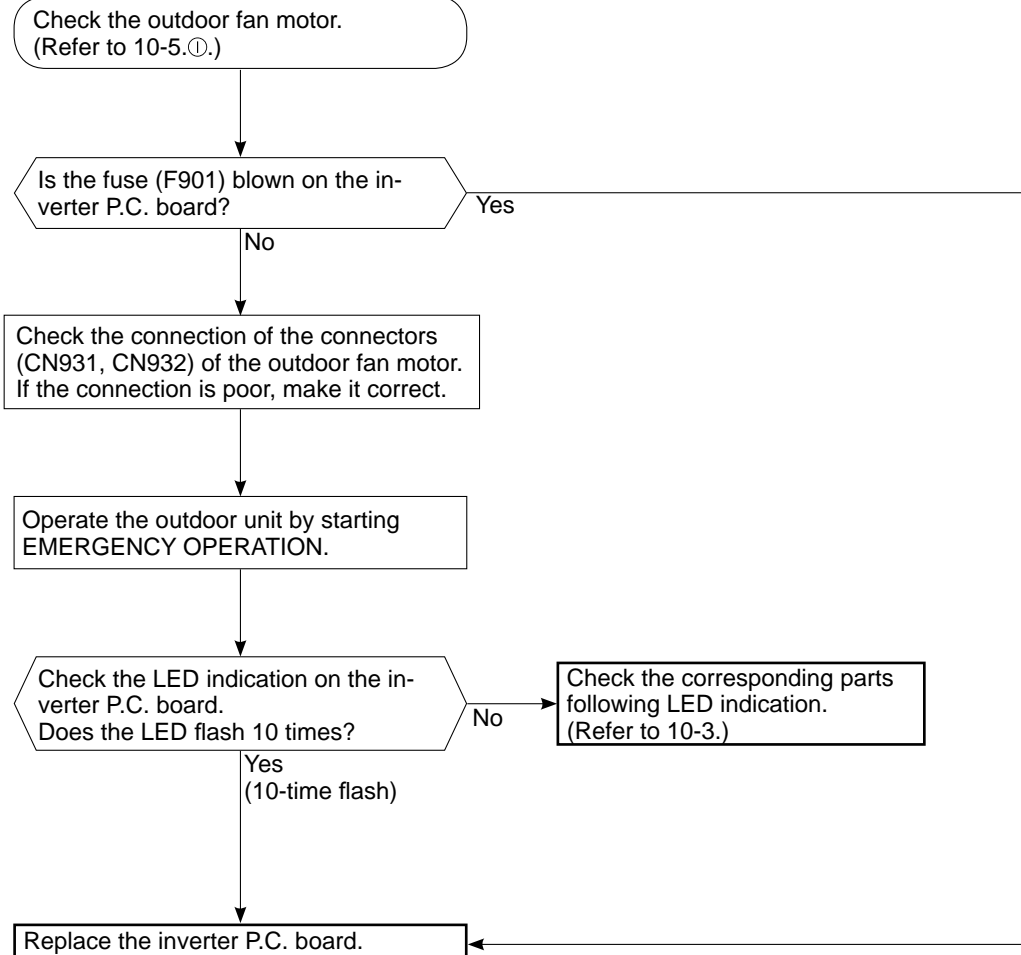

M How to check miswiring and serial signal error

NOTE: Refer to the indoor unit service manual.

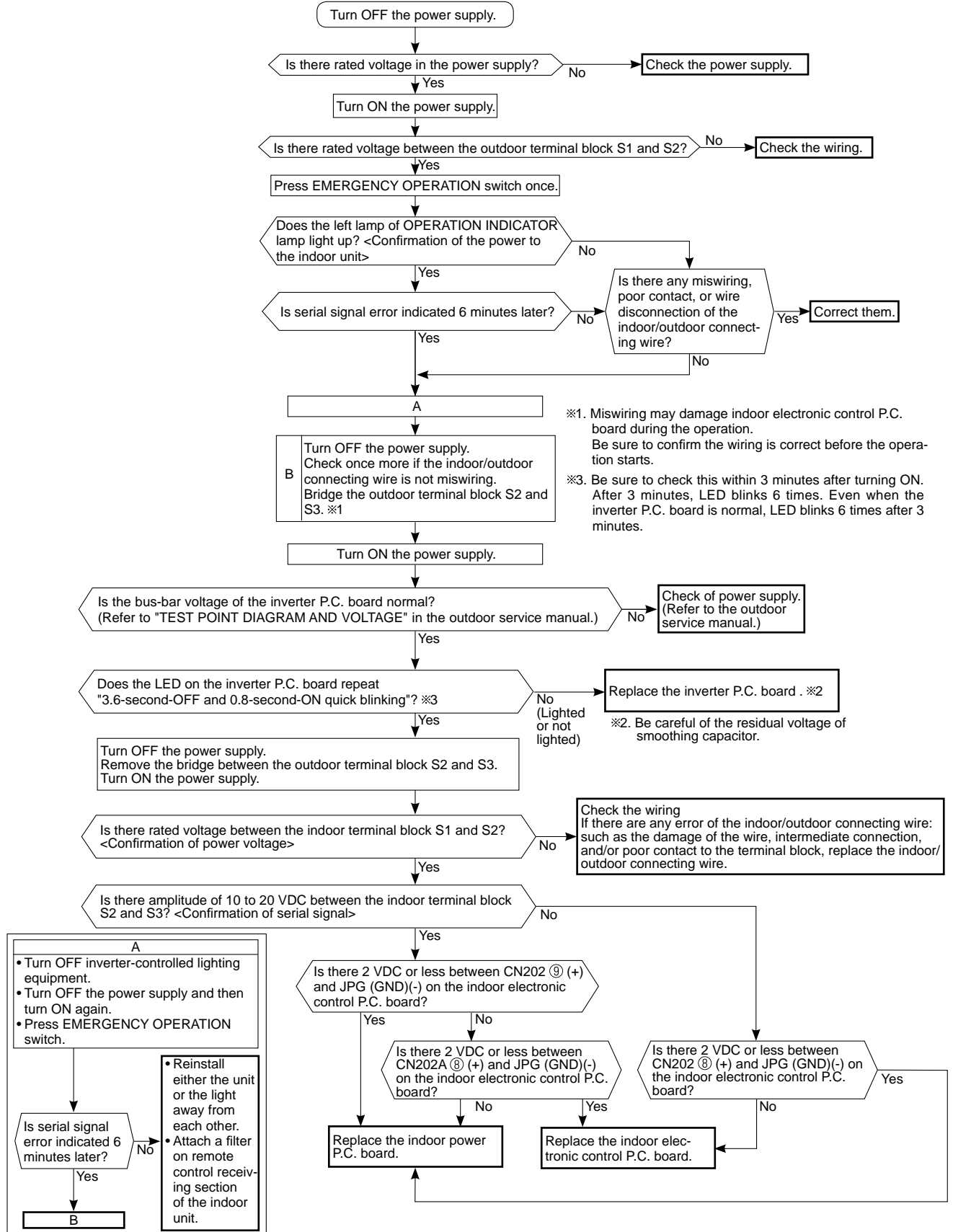

N Check of defrost heater

MUZ-FH09NAH MUZ-FH12NAH MUZ-FH15NAH

Check the following points before checking electric continuity.

1. Does the resistance of ambient temperature thermistor have the characteristics? Refer to 10-6.1.
2. Is the resistance of defrost heater normal? Refer to 10-4.
3. Does the heater protector remain conducted (not open)?
4. Are both ambient temperature thermistor and circuit of defrost heater securely connected to connectors?

In HEAT mode, for more than 5 minutes, let the ambient temperature thermistor continue to read 32°F (0°C) or below, and let the defrost thermistor continue to read 30°F (-1°C) or below.

NOTE: In case both thermistors are more than the above temperature, cool them with cold water etc...

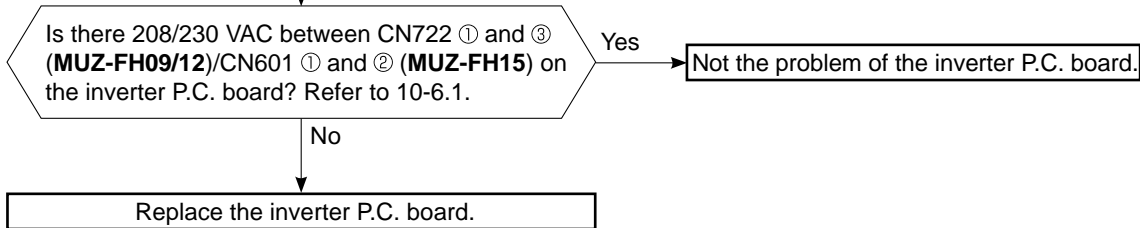

O Check of outdoor refrigerant circuit

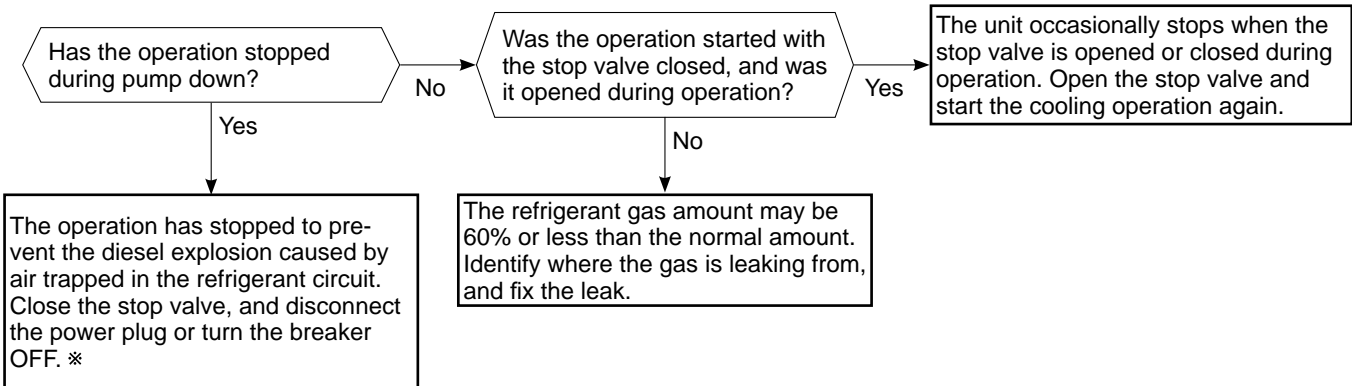

*** CAUTION :** Do not start the operation again to prevent hazards.

P Electromagnetic noise enters into TV sets or radios

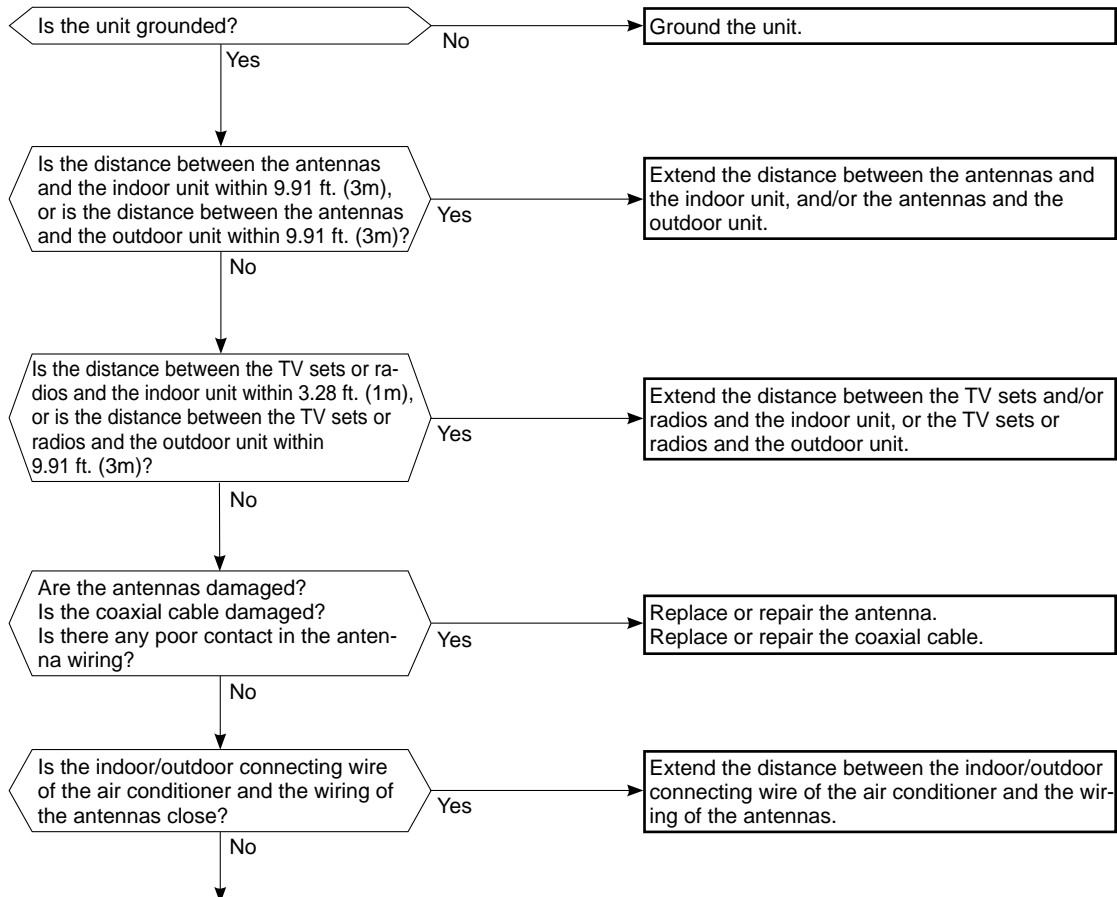

Even if all of the above conditions are fulfilled, the electromagnetic noise may enter, depending on the electric field strength or the installation condition (combination of specific conditions such as antennas or wiring).
 Check the following before asking for service.

1. Devices affected by the electromagnetic noise
 TV sets, radios (FM/AM broadcast, shortwave)
2. Channel, frequency, broadcast station affected by the electromagnetic noise
3. Channel, frequency, broadcast station unaffected by the electromagnetic noise
4. Layout of:
 indoor/outdoor unit of the air conditioner, indoor/outdoor wiring, ground wire, antennas, wiring from antennas, receiver
5. Electric field intensity of the broadcast station affected by the electromagnetic noise
6. Presence or absence of amplifier such as booster
7. Operation condition of air conditioner when the electromagnetic noise enters in
 - 1) Turn OFF the power supply once, and then turn ON the power supply. In this situation, check for the electromagnetic noise.
 - 2) Within 3 minutes after turning ON the power supply, press OPERATE/STOP (ON/OFF) button on the remote controller for power ON, and check for the electromagnetic noise.
 - 3) After a short time (3 minutes later after turning ON), the outdoor unit starts running. During operation, check for the electromagnetic noise.
 - 4) Press OPERATE/STOP (ON/OFF) button on the remote controller for power OFF, when the outdoor unit stops but the indoor/outdoor communication still runs on. In this situation, check for the electromagnetic noise.

10-6. TEST POINT DIAGRAM AND VOLTAGE

1. Inverter P.C. board

MUZ-FH09NA MUZ-FH09NAH
MUZ-FH12NA MUZ-FH12NAH

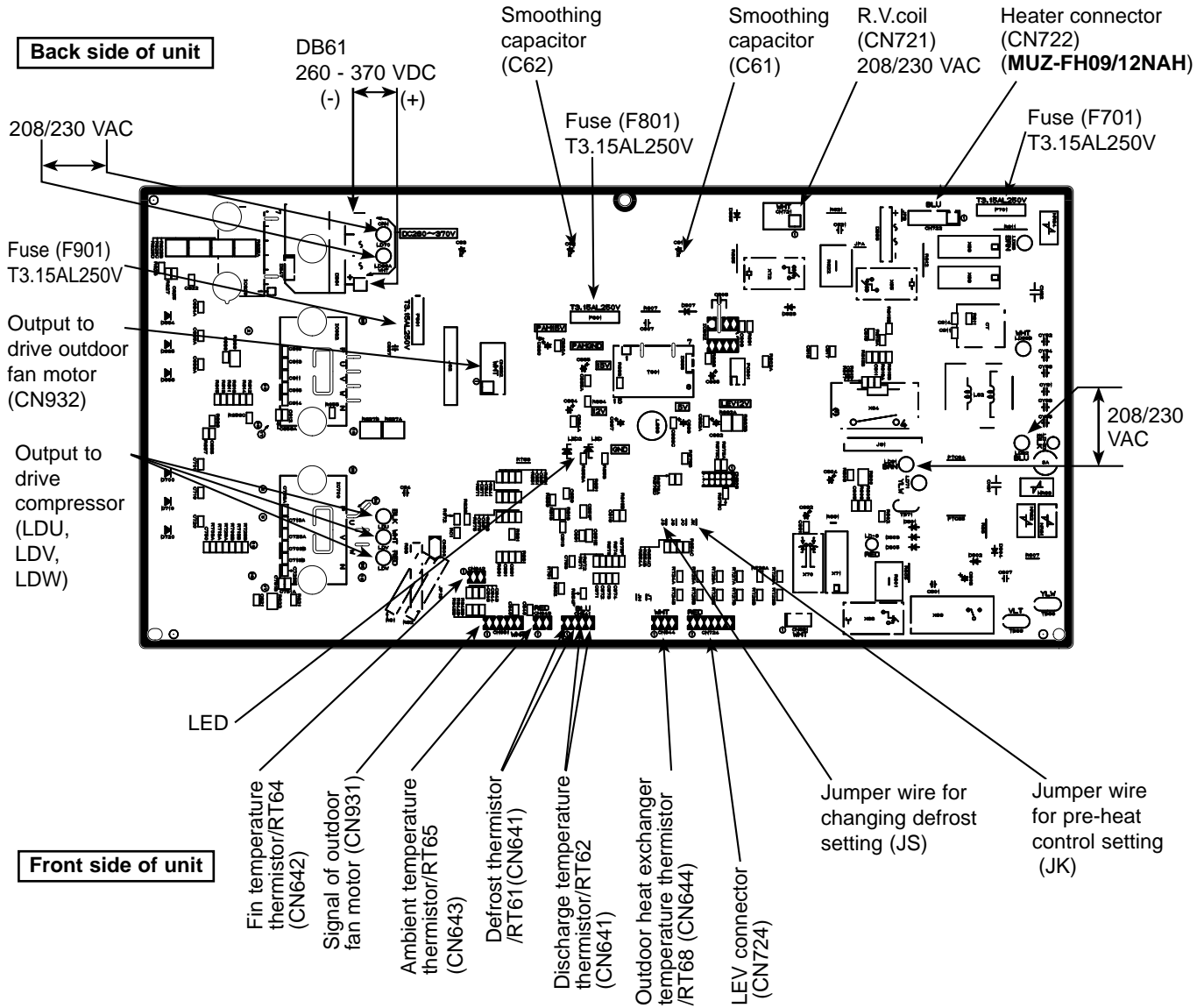

Defrost thermistor (RT61)
 Ambient temperature thermistor (RT65)
 Outdoor heat exchanger temperature thermistor (RT68)

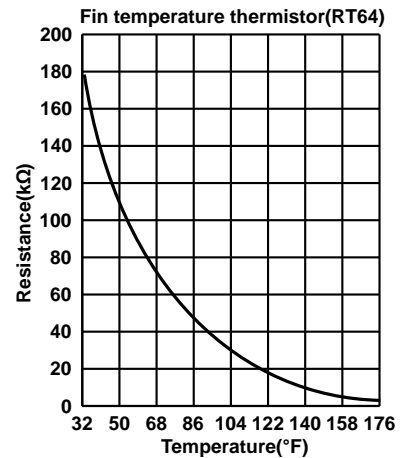
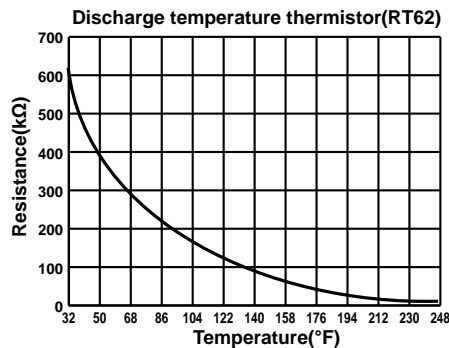
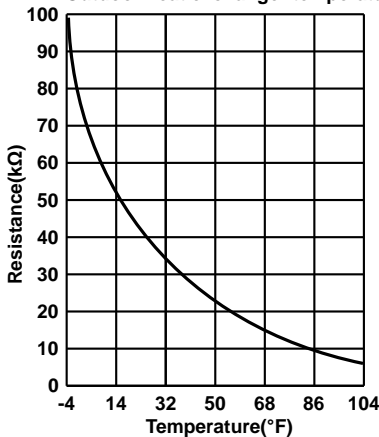

**MUZ-FH15NA
MUZ-FH15NAH**

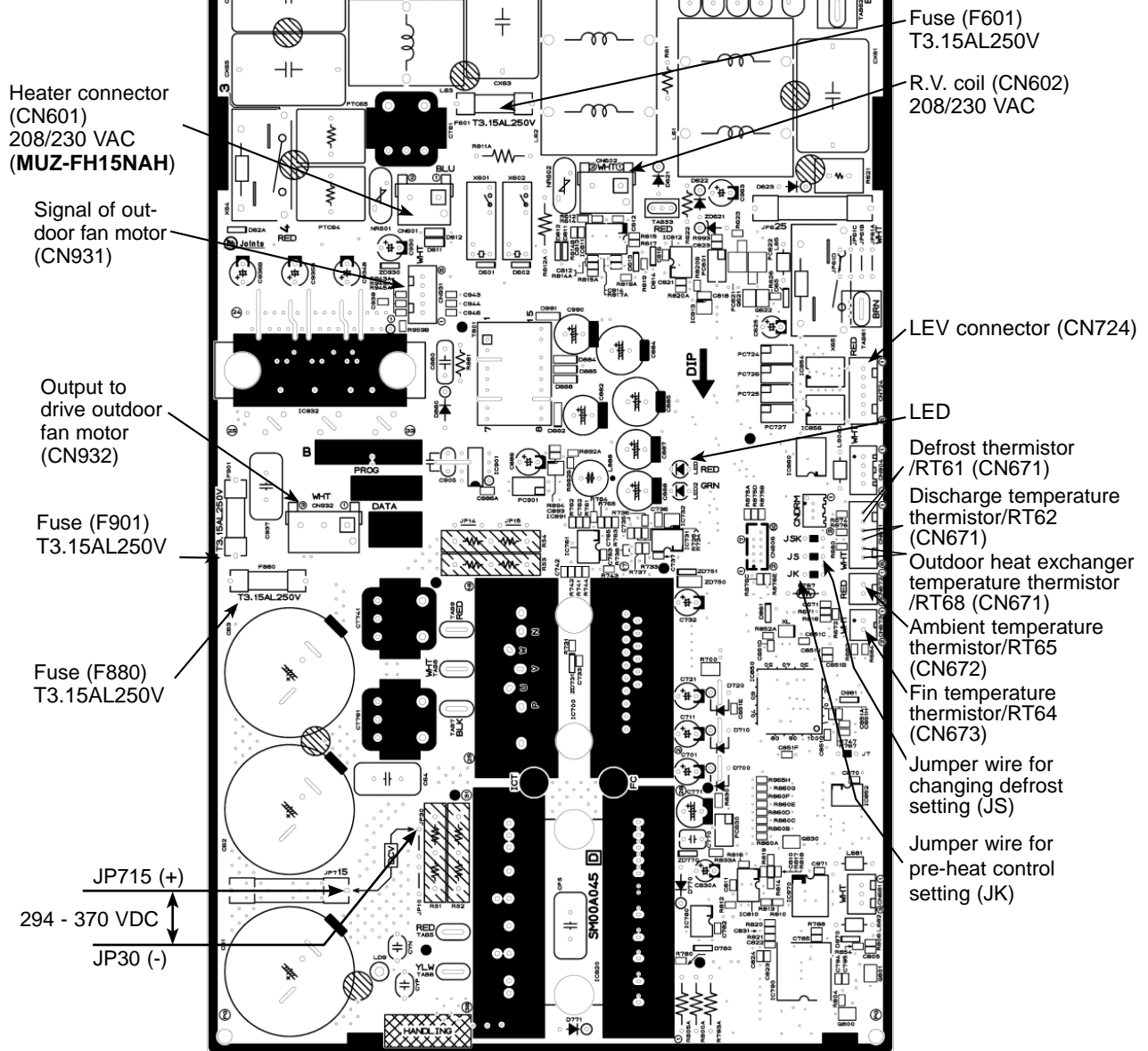

Defrost thermistor(RT61)
Ambient temperature thermistor(RT65)
Outdoor heat exchanger temperature thermistor(RT68)

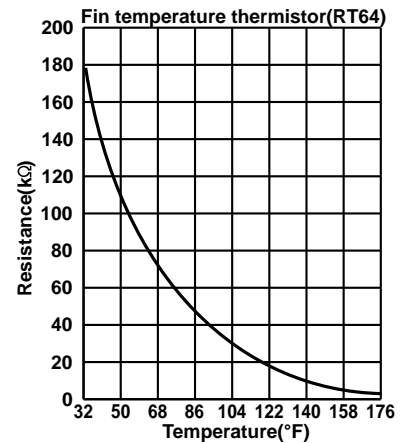
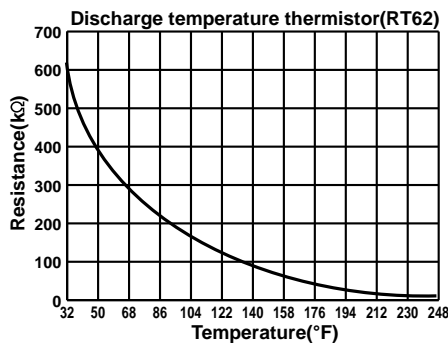
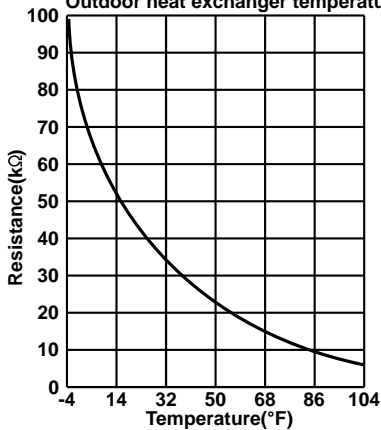

<"Terminal with locking mechanism" Detaching points>

The terminal which has the locking mechanism can be detached as shown below. There are two types (refer to (1) and (2)) of the terminal with locking mechanism. The terminal without locking mechanism can be detached by pulling it out. Check the shape of the terminal before detaching.

(1) Slide the sleeve and check if there is a locking lever or not.

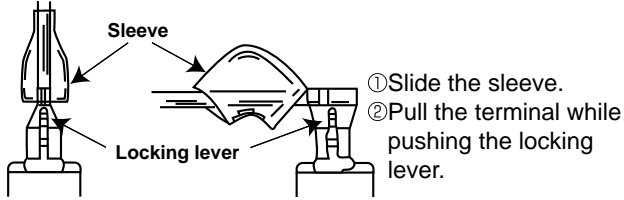

(2) The terminal with this connector has the locking mechanism.

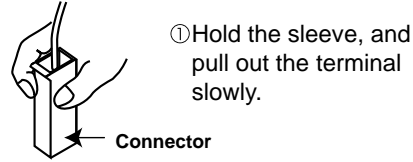

**11-1. MUZ-FH09NA MUZ-FH09NAH
MUZ-FH12NA MUZ-FH12NAH**

NOTE: Turn OFF power supply before disassembly.

| OPERATING PROCEDURE | PHOTOS |
|--|--|
| <p>1. Removing the cabinet</p> <ol style="list-style-type: none"> (1) Remove the screw fixing the service panel. (2) Pull down the service panel and remove it. (3) Remove the screws fixing the conduit cover. (4) Remove the conduit cover. (Photo 4) (5) Remove the screw fixing the conduit plate. (Photo 5) (6) Remove the conduit plate. (7) Disconnect the power supply wire and indoor/outdoor connecting wire. (8) Remove the screws fixing the top panel. (9) Remove the top panel. (10) Remove the screws fixing the cabinet. (11) Remove the cabinet. (12) Remove the screws fixing the back panel. (13) Remove the back panel. <p>Photo 2</p> <p>Screws of the top panel Screws of the cabinet</p> | <p>Photo 1</p> <p>Screws of the top panel Back panel Screws of the back panel Service panel Screws of the cabinet</p> <p>Photo 3</p> <p>Screw of the cabinet Screws of the terminal block support and the back panel Screws of the cabinet Hooks Direction to remove</p> |

OPERATING PROCEDURE

PHOTOS

Photo 4

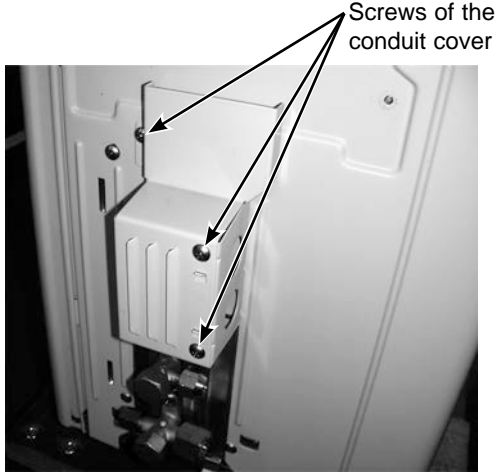
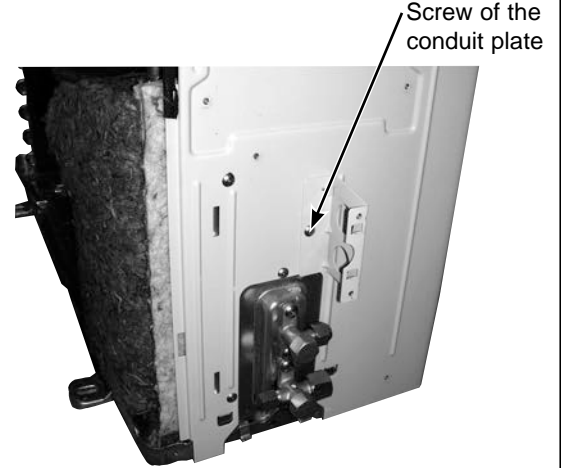

Photo 5



2. Removing the inverter assembly, inverter P.C. board

- (1) Remove the cabinet and panels. (Refer to 1.)
- (2) Disconnect the lead wire to the reactor and the following connectors:
 - <Inverter P.C. board>
 - CN721 (R.V. coil)
 - CN722 (Defrost heater and heater protector) (**MUZ-FH09/12NAH**)
 - CN931, CN932 (Fan motor)
 - CN641 (Defrost thermistor and discharge temperature thermistor)
 - CN643 (Ambient temperature thermistor)
 - CN644 (Outdoor heat exchanger temperature thermistor)
 - CN724 (LEV)
- (3) Remove the compressor connector (CN61).
- (4) Remove the screws fixing the heat sink support and the separator.
- (5) Remove the fixing screws of the terminal block support and the back panel.
- (6) Remove the inverter assembly.
- (7) Remove the screw of the ground wire and screw of the terminal block support.
- (8) Remove the heat sink support from the P.C. board support.
- (9) Remove the screw of the inverter P.C. board and remove the inverter P.C. board from the P.C. board support.

Photo 6

Screws of the heat sink support and the separator

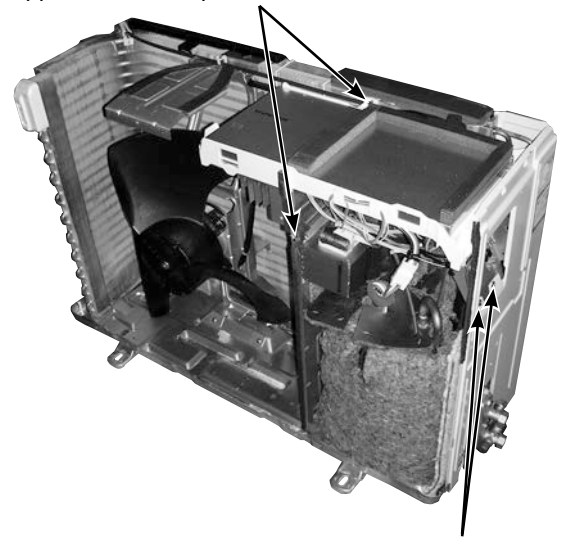

Screws of the terminal block support and the back panel

3. Removing R.V. coil

- (1) Remove the cabinet and panels. (Refer to 1.)
- (2) Disconnect the following connectors:
 - <Inverter P.C. board>
 - CN721 (R.V. coil)
- (3) Remove the R.V. coil.

Photo 7

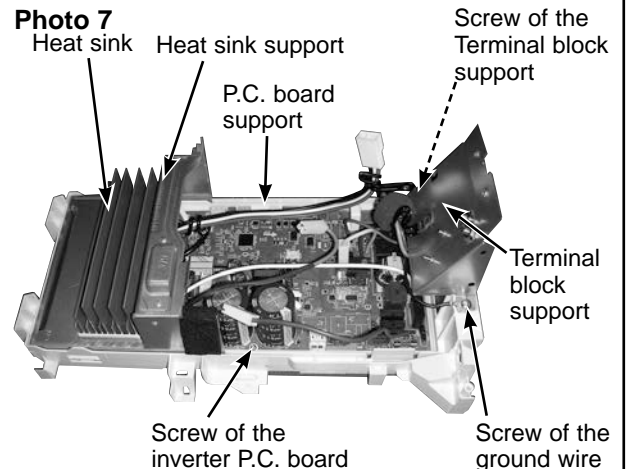

OPERATING PROCEDURE

4. Removing the discharge temperature thermistor, defrost thermistor, outdoor heat exchanger temperature thermistor and ambient temperature thermistor

- (1) Remove the cabinet and panels. (Refer to 1.)
- (2) Disconnect the lead wire to the reactor and the following connectors:
<Inverter P.C. board>
CN641 (Defrost thermistor and discharge temperature thermistor)
CN643 (Ambient temperature thermistor)
CN644 (Outdoor heat exchanger temperature thermistor)
- (3) Pull out the discharge temperature thermistor from its holder.
- (4) Pull out the defrost thermistor from its holder. (Photo 6)
- (5) Pull out the outdoor heat exchanger temperature thermistor from its holder. (Photo 6)
- (6) Pull out the ambient temperature thermistor from its holder.

PHOTOS

Photo 8

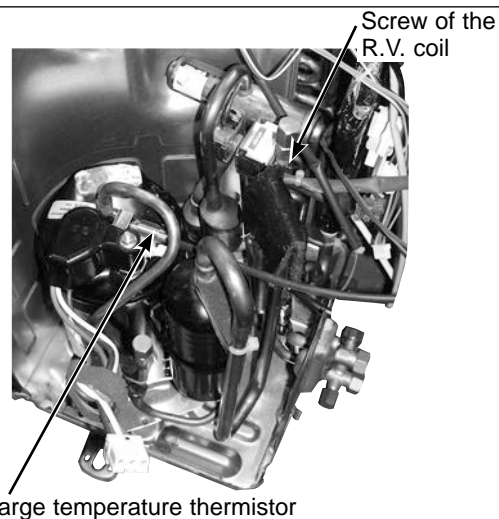

Photo 9

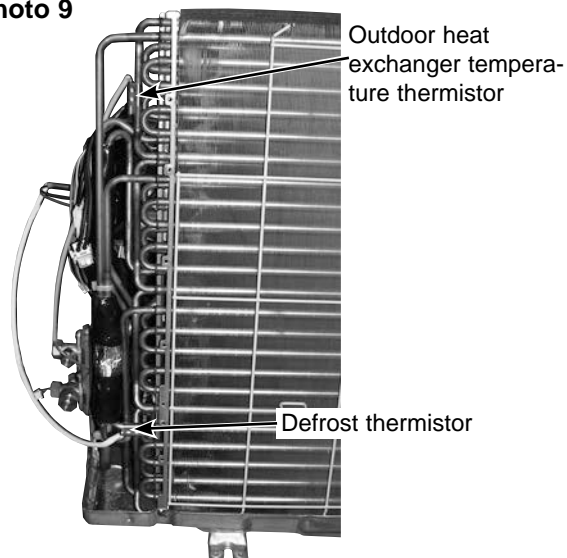
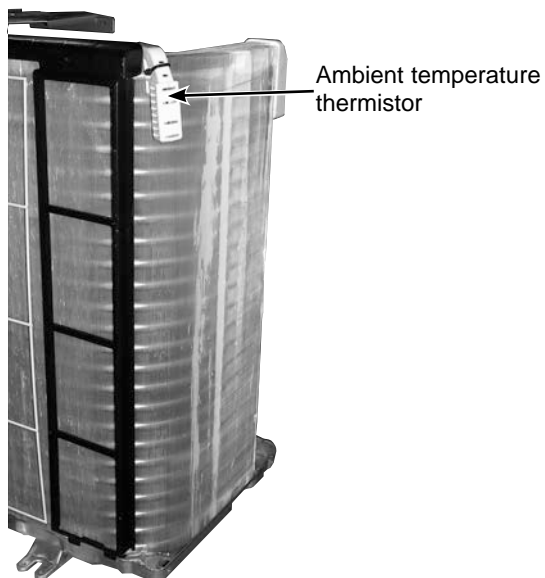

Photo 10





OPERATING PROCEDURE

5. Removing outdoor fan motor

- (1) Remove the cabinet and panels. (Refer to 1.)
- (2) Disconnect the following connectors:
<Inverter P.C. board>
CN931, CN932 (Fan motor)
- (3) Remove the propeller nut.
- (4) Remove the propeller.
- (5) Remove the screws fixing the fan motor.
- (6) Remove the fan motor.

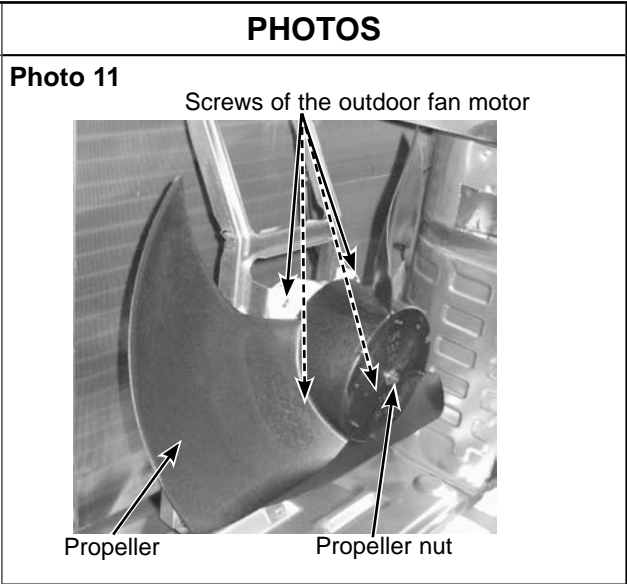



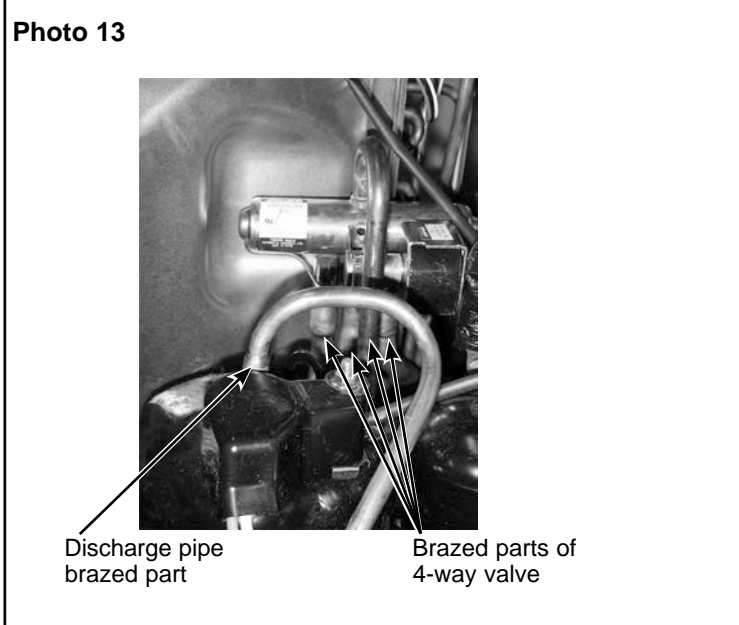
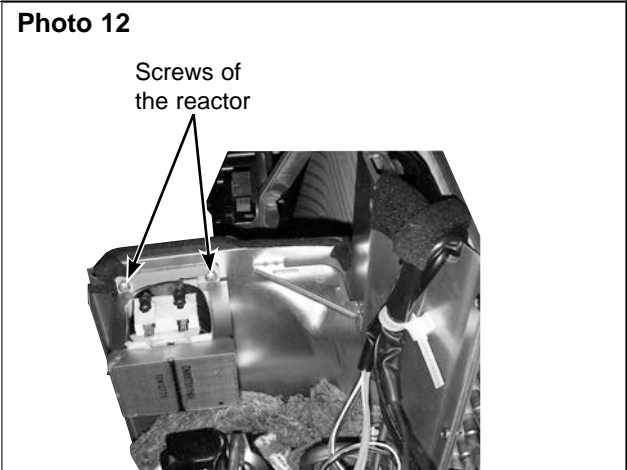

6. Removing the compressor and 4-way valve

- (1) Remove the cabinet and panels. (Refer to 1.)
- (2) Remove the inverter assembly. (Refer to 2.)
- (3) Remove the screws fixing the reactor.
- (4) Remove the reactor.
- (5) Remove the soundproof felt.
- (6) Recover gas from the refrigerant circuit.
NOTE: Recover gas from the pipes until the pressure gauge shows 0 PSIG.
- (7) Detach the brazed part of the suction and the discharge pipe connected with compressor.
- (8) Remove the nuts fixing the compressor.
- (9) Remove the compressor.
- (10) Detach the brazed part of pipes connected with 4-way valve.

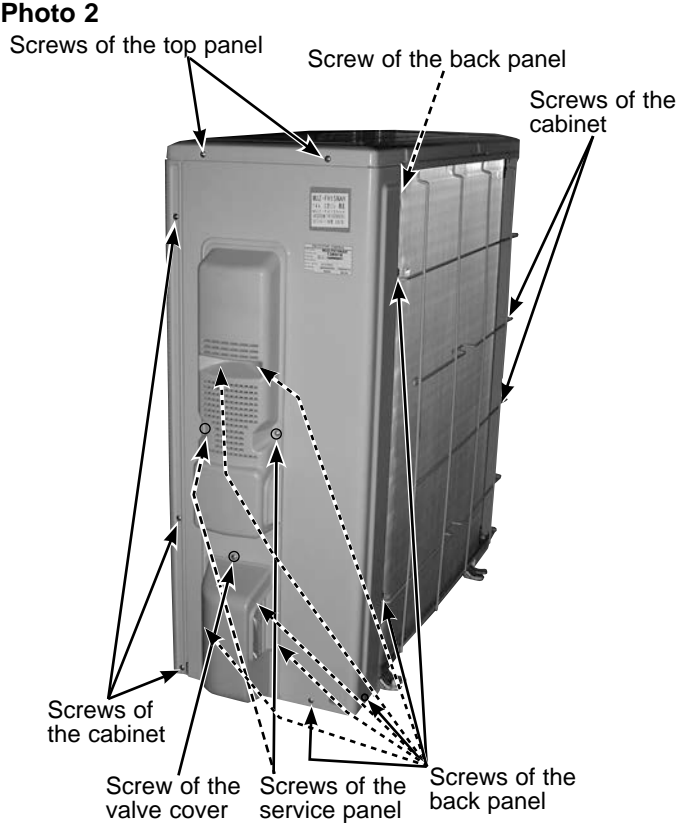
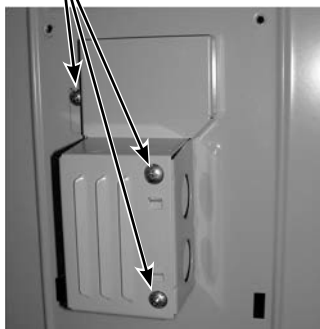

11-2. MUZ-FH15NA MUZ-FH15NAH

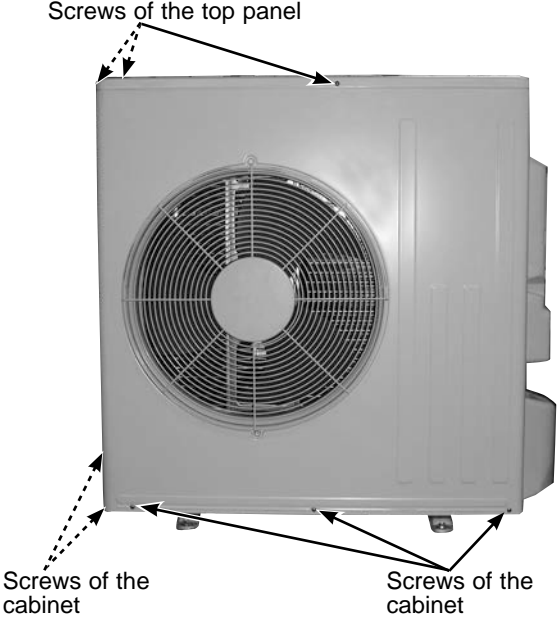
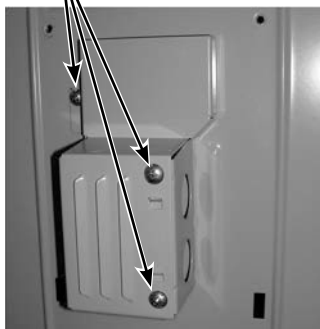
NOTE: Turn OFF power supply before disassembly.

| OPERATING PROCEDURE | PHOTOS |
|--|---|
| <p>1. Removing the cabinet</p> <ol style="list-style-type: none"> (1) Remove the screws of the service panel. (2) Remove the screws of the top panel. (3) Remove the screw of the valve cover. (4) Remove the service panel. (5) Remove the screws fixing the conduit cover. (6) Remove the conduit cover. (7) Remove the screw of fixing the conduit plate. (8) Remove the conduit plate. (9) Remove the top panel. (10) Remove the valve cover. (11) Disconnect the power supply and indoor/outdoor connecting wire. (12) Remove the screws of the cabinet. (13) Remove the cabinet. (14) Remove the screws of the back panel. (15) Remove the back panel. <p>Photo 2</p>  <p>Photo 3</p>  <p>Photo 4</p>  | <p>Photo 1</p>  <p>Photo 3</p>  <p>Photo 4</p>  |

OPERATING PROCEDURE

2. Removing the inverter assembly, inverter P.C. board and relay P.C. board

- (1) Remove the cabinet and panels. (Refer to 1.)
- (2) Disconnect the lead wire to the reactor and the following connectors:
<Inverter P.C. board>
CN602 (R.V. coil)
CN931, CN932 (Fan motor)
CN671 (Defrost thermistor, discharge temperature thermistor and outdoor heat exchanger temperature thermistor)
CN672 (Ambient temperature thermistor)
CN724 (LEV)
CN601 (Defrost heater and heater protector) (MUZ-FH15NAH)
- (3) Remove the compressor connector.
- (4) Remove the screws fixing the relay panel.
- (5) Remove the relay panel.
- (6) Remove the ground wires and the lead wires of the inverter P.C. board.
- (7) Remove the screws of the P.B. support.
- (8) Remove the inverter P.C. board from the P.B. support.

3. Removing R.V. coil

- (1) Remove the cabinet and panels. (Refer to 1.)
- (2) Disconnect the following connector:
<Inverter P.C. board>
CN602 (R.V. coil)
- (3) Remove the R.V. coil.

PHOTOS

Photo 5

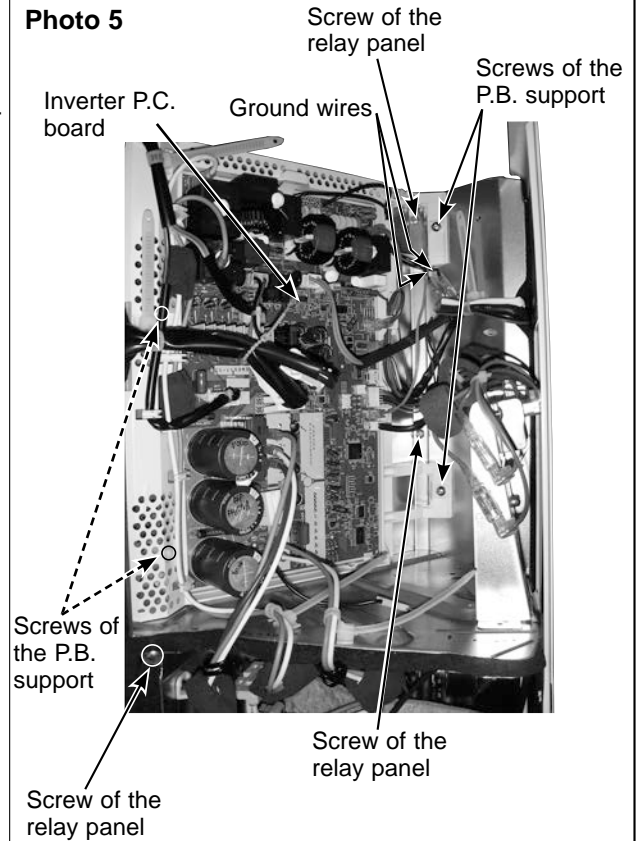

Photo 6



OPERATING PROCEDURE

4. Removing the discharge temperature thermistor, defrost thermistor, outdoor heat exchanger temperature thermistor and ambient temperature thermistor

- (1) Remove the cabinet and panels. (Refer to 1.)
- (2) Disconnect the lead wire to the reactor and the following connectors:
 - <Inverter P.C. board>
 - CN671 (Defrost thermistor, discharge temperature thermistor and outdoor heat exchanger temperature thermistor)
 - CN672 (Ambient temperature thermistor)
- (3) Pull out the discharge temperature thermistor from its holder.
- (4) Pull out the defrost thermistor from its holder.
- (5) Pull out the outdoor heat exchanger temperature thermistor from its holder.
- (6) Pull out the ambient temperature thermistor from its holder.

5. Removing outdoor fan motor

- (1) Remove the top panel, cabinet and service panel. (Refer to 1.)
- (2) Disconnect the following connectors:
 - <Inverter P.C. board>
 - CN931 and CN932 (Fan motor)
- (3) Remove the propeller.
- (4) Remove the screws fixing the fan motor.
- (5) Remove the fan motor.

6. Removing the compressor and 4-way valve

- (1) Remove the top panel, cabinet and service panel. (Refer to 1.)
 - (2) Remove the back panel. (Refer to 1.)
 - (3) Remove the inverter assembly. (Refer to 2.)
 - (4) Remove the soundproof felt.
 - (5) Recover gas from the refrigerant circuit.
- NOTE:** Recover gas from the pipes until the pressure gauge shows 0 PSIG.
- (6) Detach the brazed part of the suction and the discharge pipe connected with compressor.
 - (7) Remove the nuts fixing the compressor.
 - (8) Remove the compressor.
 - (9) Detach the brazed parts of 4-way valve and pipe. (Photo 4)

PHOTOS

Photo 7

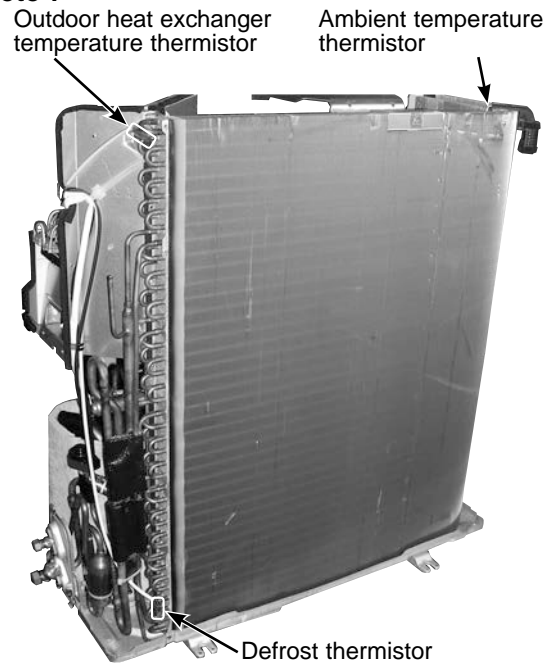

Photo 8

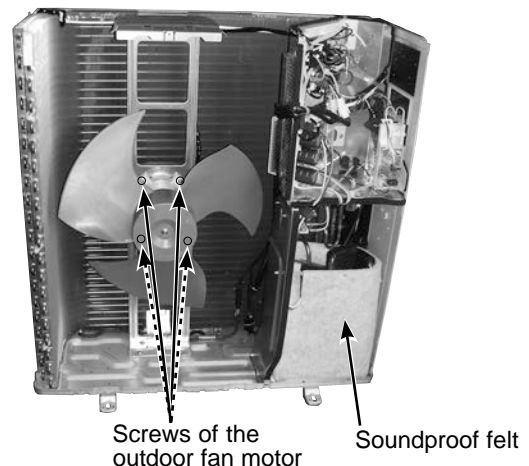
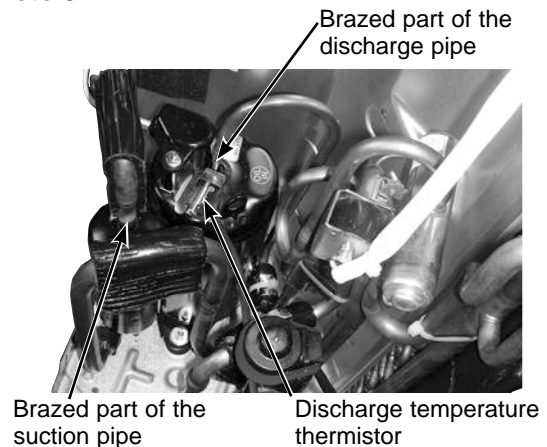

Photo 9



mitsubishi electric corporation

HEAD OFFICE: TOKYO BLDG., 2-7-3, MARUNOUCHI, CHIYODA-KU, TOKYO 100-8310, JAPAN

© Copyright 2014 MITSUBISHI ELECTRIC CORPORATION
Distributed in Apr. 2014. No. OBH684 REVISED EDITION-A
Distributed in Feb. 2014. No. OBH684
Made in Japan

New publication, effective Apr. 2014
Specifications are subject to change without notice.