



## INSTALLATION AND MAINTENANCE INSTRUCTIONS

TEMP/  
GUARD®

### 2100° TEMP/GUARD CHIMNEY SIZES 6" - 7" - 8" - 10" - 12" - 14"



This symbol on the nameplate means this product is listed by Underwriters Laboratories Inc. Listing No. MH 8251 Tested to 103 HT

### 1700° TEMP/GUARD CHIMNEY SIZES 16" - 18"

A MAJOR CAUSE OF CHIMNEY RELATED FIRES IS FAILURE TO MAINTAIN REQUIRED CLEARANCES (AIR SPACES) TO COMBUSTIBLE MATERIAL.\* MINIMUM CLEARANCE FOR 6" - 8" TEMP/GUARD IS ONE AND A HALF (1-1/2) INCHES. MINIMUM CLEARANCE FOR 10" - 18" TEMP/GUARD IS TWO (2) INCHES. IT IS OF UTMOST IMPORTANCE THAT THIS CHIMNEY IS INSTALLED ONLY IN ACCORDANCE WITH THESE INSTRUCTIONS.

**WARNING: FOR SIZES 6", 7" & 8" CHIMNEY, MINIMUM CLEARANCE TO COMBUSTIBLE MATERIAL MUST BE TWO (2) INCHES UNLESS ALL CHIMNEY COMPONENTS USED ARE LABELED TG MAX.**

\*Combustible material is defined as material made of, or surfaced with, wood, compressed paper, plant fibers, plastic, or other material that will ignite and burn, whether flame proofed or not, or whether plastered or unplastered.

The Metal-Fab Temp/Guard Chimney is intended for use on any residential and building heating appliance burning gas, liquid or solid fuels such as fireplace stoves, furnaces, ranges, room heaters, or as defined in columns I and II, Table 2-2.1, NFPA 211. Contact Local Building or Fire Officials about restrictions and Installation Inspection in your area.

**WARNING: Metal-Fab Temp/Guard Chimney is not designed for use on products that operate at continuous temperatures in excess of 1,000°F.**

**WARNING: If decorative shrouds are being used with Temp/Guard Chimney, Reference the Temp/Guard Addendum L2372.**

**IMPORTANT: FOR OIL OR COAL BURNING APPLIANCES, OUTSIDE THE ENVELOPE OF THE BUILDING, USE ONLY PIPE WITH STAINLESS STEEL CASING, ALSO USE FLASHING OR STORM COLLARS CONSTRUCTED OF STAINLESS STEEL OR ALUMINUM.**

## OPERATIONAL PRECAUTIONS

- Maintain 1-1/2" minimum clearance to combustibles for 6"-8" diameters and 2" clearance to combustibles for 10"-18" diameters (Refer to **WARNING** above). Use only U.L. Listed products and INSTALL ONLY IN ACCORDANCE WITH MANUFACTURER'S INSTRUCTIONS.
- **Formation of Creosote and Soot and the need for removal.**

When wood is burned slowly, it produces tar and other organic vapors, which combine with expelled moisture to create creosote. The creosote vapors condense in the relatively cool chimney flue of the slow burning fire. As a result, creosote residue accumulates on the flue lining. When ignited, this creosote makes an extremely hot fire. The chimney should be inspected at least once every two (2) months during the heating season to determine if a creosote or soot buildup has occurred. If creosote or soot has accumulated, it should be removed to reduce the risk of chimney fire.
- Do not use fireplace for food grill. Grease from foods can collect in chimney causing fireplace to become a potential fire hazard.
- On airtight stoves, open dampers and let equipment burn hot for 15 to 20 minutes. This should be done every time fuel is added. This lessens the chance of creosote buildup.
- Some chemical chimney cleaners can be harmful to the chimney. These cause accelerated oxidation or corrosion. If chemical cleaners are used, they must be non-corrosive in nature. If brush is used, it must be of proper size with plastic bristles.

## PAINT TOUCH-UP

- The flat-black paint used on painted parts may be touched up, as required, with Stove Bright® Product No. 1990.

# INSTALLATION THROUGH FLAT CEILING(S)

1. From the appliance manufacturer's instructions, determine the correct flue diameter for the chimney, and proper location of the chimney.
2. Using framing lumber equal to ceiling joist size, frame ceiling opening as shown in FIG. 1 and TABLE 1.

TABLE 1

CHIMNEY FLUE DIAMETER								
	6"	7"	8"	10"	12"	14"	16"	18"
A	12-7/16"	13-7/16"	14-7/16"	17"	19"	22"	24"	26"
B	12-7/16"	13-7/16"	14-7/16"	17"	19"	22"	24"	26"

**NOTE:** If possible, it is recommended that the chimney be located in such a manner as to not cut the ceiling joist. For the 8TG chimney, design and testing allows the clearance to combustibles to be 1½ inches through the ceiling joist (using the 8TGCSF) and through the roof joists. The chimney can be centered between joists on 16 inch centers in these areas.

3. As shown in FIG. 2, insert the Ceiling Support (TGCSP) from below until the flanged edges are firmly against the ceiling drywall. Secure into framing with eight (8) 8-penny nails inserted through the sides of the ceiling support. If the TGCSP was installed during construction and drywall now covers the flanged edges, install Metal-Fab's ceiling support trim kit (TGCST), as shown in FIG. 3.
4. Single wall or double wall connector pipe may now be installed between the appliance and the ceiling support. (See FIG 2.)

**If the area above the ceiling is an attic, go to step 7.**

5. Proceed to the next ceiling. **If Metal-Fab Elbows are to be used because the chimney is to be offset, refer to "Installation of Elbows" section.** Directly above the Center of the flue in the ceiling support, mark the ceiling. A plumb bob is normally used to find the center. Cut an opening in the ceiling using FIG. 1 and Table 1.
6. Install Temp Guard chimney sections starting at the TGCSP. Secure the sections by pushing together and twisting until stop-locked (See FIG. 3a). Additional chimney sections may be added to maximum height of 60 feet. 14", 16" and 18" are installed flange to flange, as illustrated on page 6. At each additional ceiling, a firestop (TGFS) is required. Insert the TGFS into the joist area prepared in step 5. Continue this process for each floor level until the area above the attic.

**NOTE:** When the chimney extends between floors, which can be occupied, the chimney must be enclosed to prevent contact. As previously noted, 1-1/2" clearance to combustibles for 6"-8" diameters and 2" clearance to combustibles for 10" to 18" diameters is to be maintained, except within the joist area controlled by the TGCSP.

7. The first chimney section through the joist area into attic is to be approximately two (2) feet. If the pipe sections in the attic are not enclosed, an insulation shield (TGIS) must be installed. Lower insulation shield (TGIS) over TG pipe until the flange is resting on the joist. Secure the TGIS in place by nailing the flange to the joist. See FIG. 4. **If the section within the attic area is to be chase enclosed,** the TGIS is not required.
8. Continue the chimney to the roof. See "Flashing Installation" and "Termination" sections.

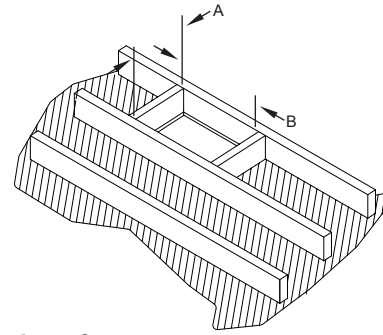

FIG. 1  
Framing lumber of equal size to the joist should be used.

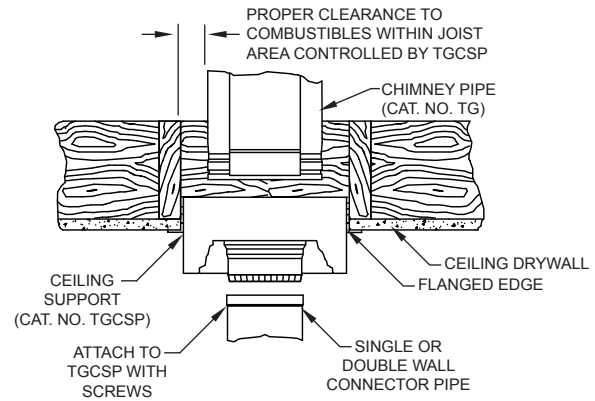

FIG. 2

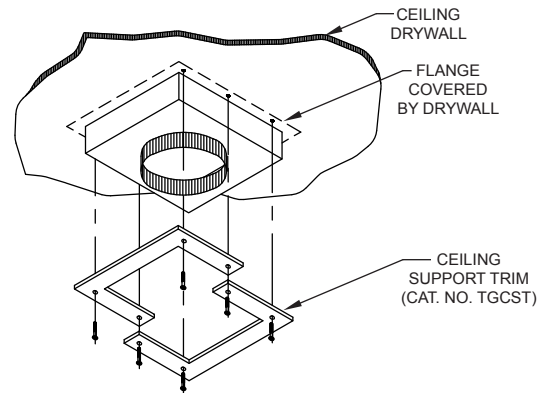

FIG. 3

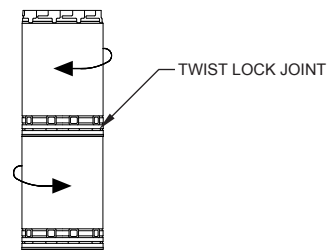

FIG. 3a

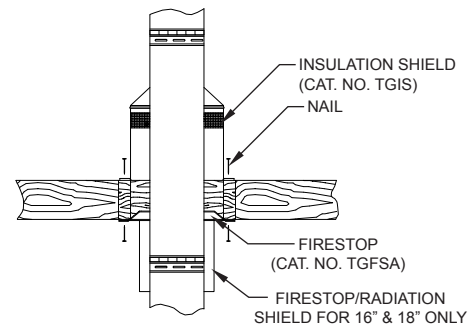

FIG. 4

# INSTALLATION THROUGH SIDE WALL

1. Locate the area where the chimney section is to penetrate the vertical wall. Cut and frame an opening so that the flue is centered between the vertical wall studs on 6", 7" and 8" systems. Note that 10", and 12" systems may require relocation of wall studs to maintain 2" clearance to combustibles. Consult local authorities if structural modifications are required. Frame opening per **FIG. 5** and **Table 2**.

TABLE 2

CHIMNEY FLUE DIAMETER		6"	7"	8"	10"	12"	14"	16"	18"
A		12-7/16"	13-7/16"	14-7/16"	17"	19"	N/A	N/A	N/A
B		13"	14"	15"	17"	19"	N/A	N/A <td N/A	

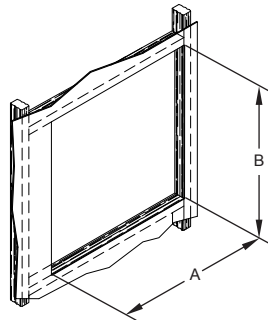
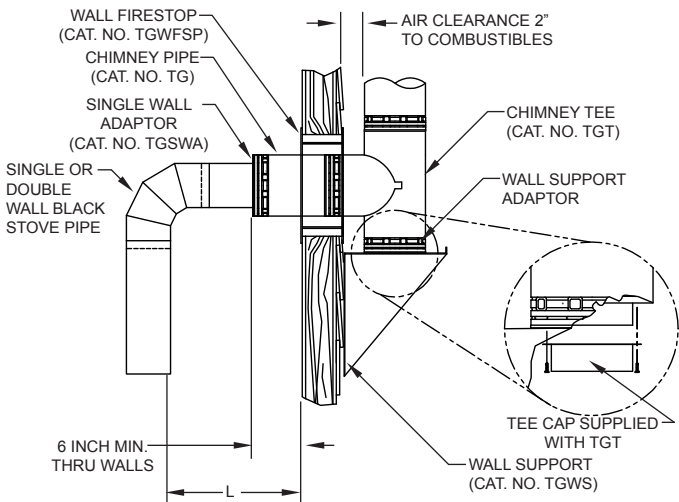

FIG. 5

2. A wall firestop (TGWFS) must be installed in framed opening from the outside. Push remaining half through opening from inside until plate is flush. Use four (4) #10 x 2 1/2" wood screws to attach to opening. (See **FIG. 6**).



L=18" FOR SINGLE WALL BLACK STOVE PIPE  
L=6" FOR DOUBLE WALL BLACK STOVE PIPE

FIG. 6

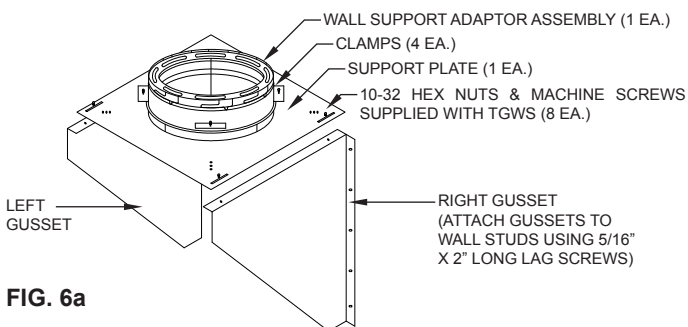

FIG. 6a

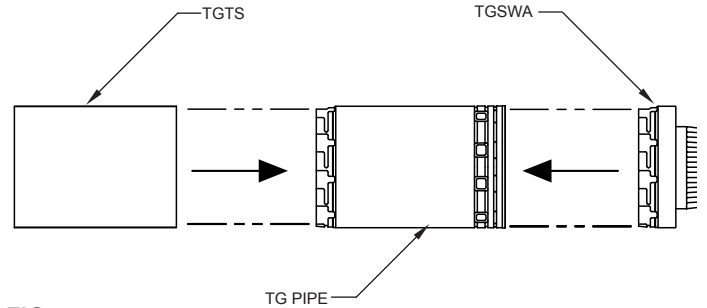

FIG. 7a

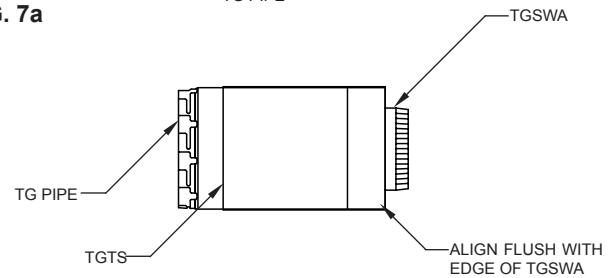

FIG. 7b

- Remove wall support adaptor from TGWS box and attach adaptor to bottom of tee by inserting into bottom of tee and rotating to lock.
- Insert the side tap of the tee into the opening in the wall firestop.
- Assemble right and left gusset to support plate using hardware provided.
- Attach wall support plate to wall support adaptor using 4 clamps provided. Do not tighten. (See **FIG. 6a**).
- Align wall support with wall and secure to wall studs using 5/16" x 2" lag screws (not provided). **DO NOT SECURE TO SIDING.** For masonry walls, use 5/16" x 2" masonry lag bolts.
- Install tee cap to bottom of wall support adaptor with a minimum of two (2) #10 x 1/2" sheet metal screws.
- Position tee and adapter on wall support to maintain 2" clearance to combustibles. **TIGHTEN CLAMPS.**
- Slip a trim sleeve joint cover (TGTS) over the male end of TG pipe that is to reach through the wall firestop to the tee. Attach single wall adaptor (TGPSWA) to the female end of TG pipe and slip TGTS flush to the end of TGPSWA. (See **FIG. 7a** and **7b**.)
- Slide Metal-Fab chimney pipe into top of tee. Align male and female ends. Push down on pipe sections and turn clockwise to lock. Additional chimney sections are added and locked to a **MAXIMUM OF 60 FEET**. As sections are added, it will be necessary to secure them to the outside wall with bands (TGSWB) at eight-foot intervals and 2" from combustibles. Wall bands (TGSWB) are secured to the chimney by placing band around the chimney and tightening clamping bolt. The assembly is anchored to the wall studs (not the siding) with 5/8" x 2" lag bolts. To complete the chimney installation, see "Flashing Installation" and "Termination" sections.

# INSTALLATION THROUGH HIGH PITCH OR CHALET CEILING USING TGRS

1. From the appliance manufacturer's instructions, determine the correct flue diameter for the chimney and proper location of the chimney.
2. Using framing lumber equal to ceiling joist size, frame opening as shown in **FIG. 9**. Framing that is perpendicular to the roof joists must also be vertically mounted so that support can be installed vertically.

Opening dimensions will vary based on roof pitch (slope). Framed openings should be approximately 1/4" larger than support. The TGRS dimensions are:

	LENGTH		WIDTH	HEIGHT
6" TGRS	12-7/16"	X	12-7/16"	29"
7" TGRS	13-7/16"	X	13-7/16"	29"
8" TGRS	14-7/16"	X	14-7/16"	29"
10" TGRS	16-7/16"	X	16-7/16"	29"
12" TGRS	18-7/16"	X	18-7/16"	29"

3. Insert TGRS into framed opening so that the TGRS extends a MINIMUM of three (3) inches below the finished ceiling on the lower side of the installation.
4. With TGRS properly located, mark roof slope on the roof support (See **FIG. 10**.), Remove from opening and trim off excess metal.
5. Reinsert TGRS and secure in position using a minimum 1" roofing nail, four (4) each per side.
6. The TGRS contains an integral starter collar for TG chimney. Attach first section of pipe to TGRS.
7. Continue pipe through the roof. See "Flashing Installation" and "Termination" sections.

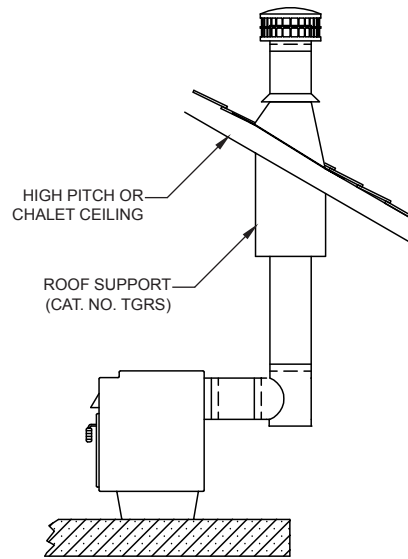

**FIG. 8**

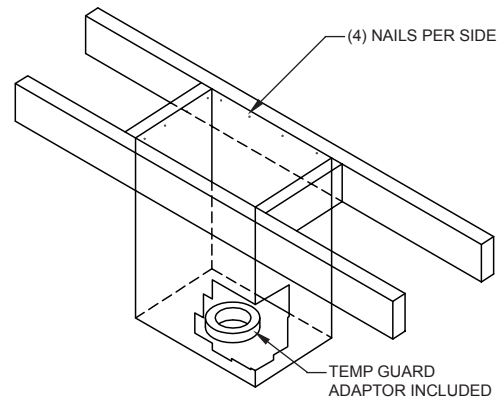

**FIG. 9**

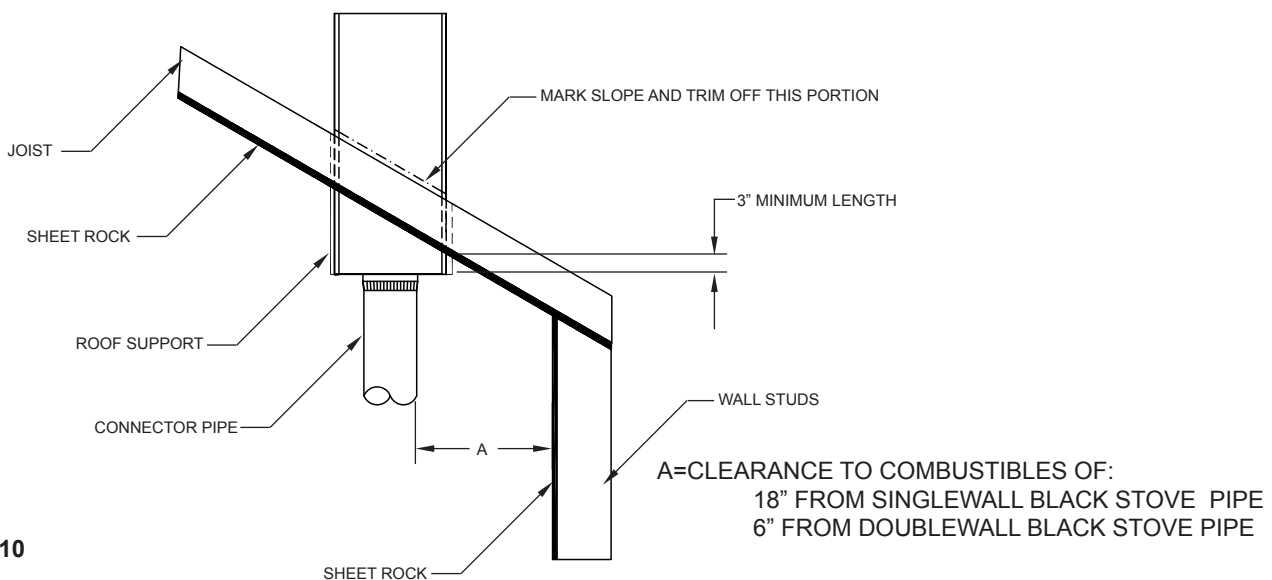

**FIG. 10**

# INSTALLATION THROUGH HIGH PITCH OR CHALET CEILING USING TGAS

1. From the appliance manufacturer's instructions, determine the correct flue diameter for the chimney and proper location of the chimney.
2. Using framing lumber equal to ceiling joist size, frame opening providing a minimum 1-1/2" clearance for 6"-8" diameters and 2" clearance for 10" - 18" diameters from the chimney to combustibles. Opening dimensions will vary based on roof pitch (slope).
3. Assemble TGAS as shown in **FIG 12**. Tighten nuts finger tight only.
4. Locate the TGAS over the framed opening in the roof. Nail the brackets to the framing using a minimum of two (2) #8 nails per bracket.
5. Slip a trim sleeve joint cover (TGTS) over the end of the TG pipe that is to go through the support and protrude into the house. Attach a single adaptor (TGPSWA) to the female end of the TG pipe and slip TGTS flush to the end of the TGPSWA.
6. From below, slide TG chimney pipe section through the opening and through the support band. Drill 1/8" holes into the exterior casing of the TG pipe at each pilot hole in the support band. **DO NOT PENETRATE FLUE**. Secure the support band to the chimney using sheet metal screws provided with the TGAS assembly.
7. Adjust the pipe section so that it stands vertically through the roof. **TIGHTEN** all nuts to secure the pipe in the vertical position.
8. The interior opening in the ceiling may be trimmed with a TGPCP. Select the appropriately shaped trim plate for your ceiling pitch (slope). Slide the trim plate over the opening and secure to the ceiling. Determine ceiling pitch as shown in **FIG. 13**.
9. **WARNING:** Use only Single Wall or Double Wall Black Stove Pipe connector below the ceiling line as shown in **FIG. 11**. Use of additional TG pipe as a connector is prohibited.

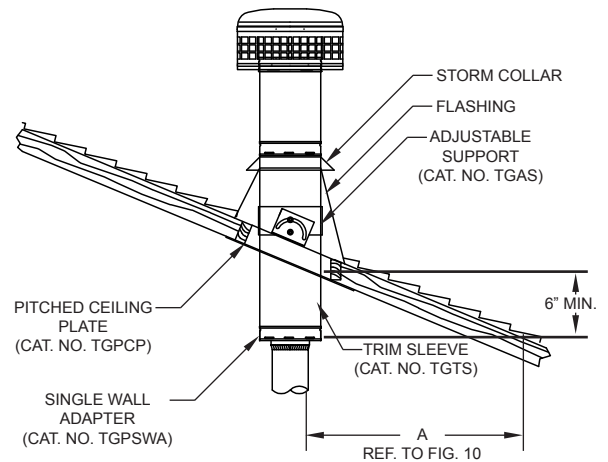

**FIG. 11**

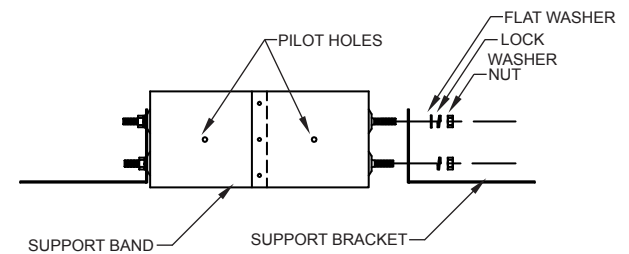

**FIG. 12**

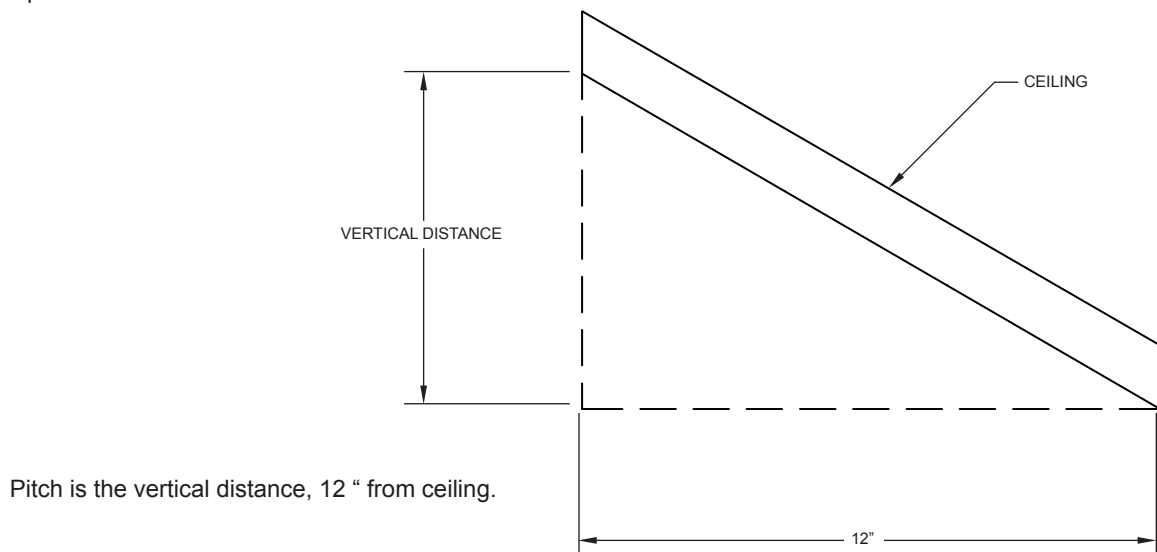

Pitch is the vertical distance, 12" from ceiling.

Example: In a 6/12 pitch, the vertical distance is six (6) inches.

**FIG. 13**

# MASONRY FIREPLACE CHIMNEY, AND CHIMNEY EXTENSION

An anchor plate (TGAP) is used to attach Metal-Fab 2100°F or 1700°F Chimney to a masonry fireplace or chimney. Maximum support height of 60 ft (45 ft for 14", 16" and 18").

1. Where the transition is to be made, apply a bed of mortar approximately 3/4 inches deep and approximately one (1) inch larger than the anchor plate. (See TG Chimney Catalog for anchor plate dimensions).
2. Insert four (4) 1/4-20 x 2" anchor bolts, head down into the mortar bed. J-style anchor bolts are preferred. An alternate method would be to allow the mortar bed to cure. Then, drill four (4) holes, matching the holes in the anchor plate and insert four (4) each 1/4-20 metal anchors. The anchor plate would then be attached by four (4) each 1/4-20 bolts.
3. Before the mortar sets, place the anchor plate over the bolts and press down into the mortar. Loosely secure using a washer and nut on each bolt.
4. Use a level to check the installation, assuring that the TG chimney connection (TGAP) is level.
5. When the mortar has set up, tighten the nuts onto the bolts. Proceed to stack Metal-Fab chimney pipe (TG) on the anchor plate.
6. When installing the 14TG, 16TG and 18TG chimney system, use the flange bands for each flue connection and the closure bands around the casing connections. Prior to installing the closure band, wrap the flue with the ceramic insulation provided with each section.

**NOTE:** No insulation is required when attaching the chimney cap.

7. To attach the 14TGC, 16TGC and 18TGC cap to the chimney, set the flue flange of the cap on the flue flange of the last piece of pipe. Rotate the V-band around the flanges and tighten. Wrap the closure ring around the flue of the cap and tighten. This closure ring protects the area between the flue and the casing and keeps moisture out of this area.
8. See "Flashing Instructions" and "Termination" sections.

**NOTE:** Existing masonry flues may be extended with TG pipe by using an anchor plate, following steps 1 through 7 above, provided that:

- a) The existing masonry chimney is structurally sound, and;
- b) The flue extension is properly sized so that the appliance attached to the flue drafts properly.

**NOTE:** The TG flue size for a height less than 15 feet should be at least 1/8 the area of the fireplace opening. The TG flue size for a height over 15 feet should be at least 1/10 the area of the fireplace opening. (For sizing of TG flue, See Metal-Fab literature L1372.)

**EXAMPLE:** A fireplace opening of 22" x 34" has an area of (748 in<sup>2</sup>) with a chimney height less than 15 feet, the effective area is 1/8 x (748 in<sup>2</sup>) = 93.5 in<sup>2</sup>. Closest flue diameter size = 10".

With a chimney height over 15 Feet, the effective area is 1/10 x (748 in<sup>2</sup>)=74.8 in<sup>2</sup>. closest flue diameter size = 10".

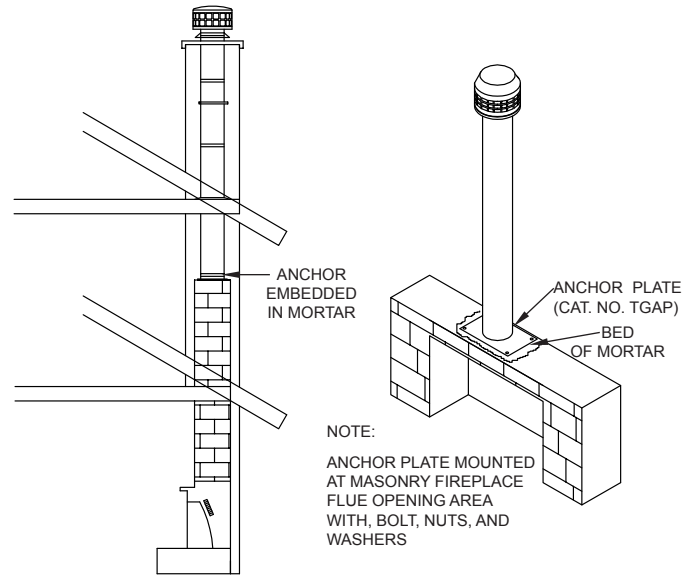

FIG. 14

FIG. 15a

## 14TG THROUGH 18TG DETAIL

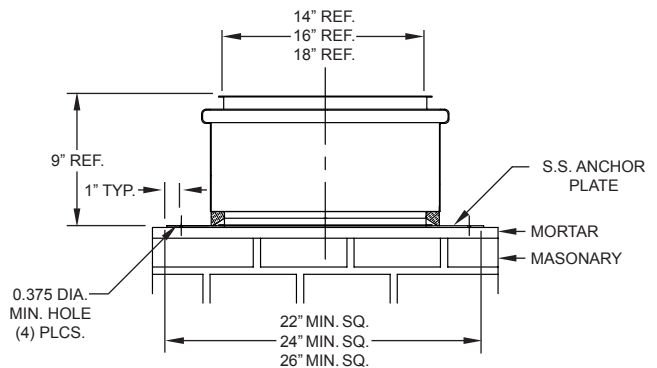
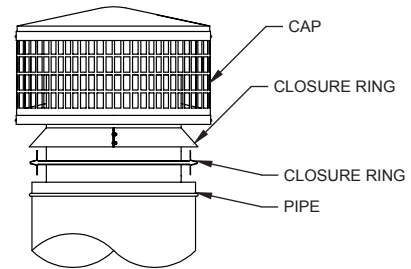

FIG. 15b 14TG, 16TG, AND 18TG ANCHOR PLATE

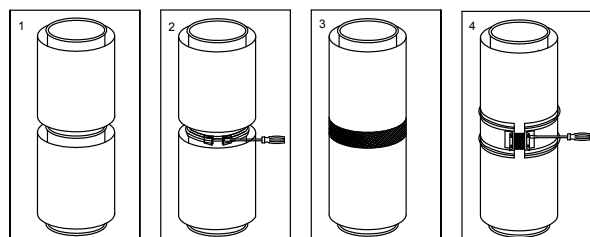

FIG. 16

# ELBOW INSTALLATION

1. Metal-Fab provides a 15° (TGA15) and 30° (TGA30) Elbow to allow chimneys to avoid framing member or roof peaks. A maximum of 30° from the vertical is allowed, and a total of four elbows (two pair) for each chimney installation. Maintain 1-1/2" clearance to combustibles for 6" - 8" diameters and 2" clearance to combustibles for 10" - 18" diameters.

**NOTE:** The flues of the 14" TG, 16" TG and 18" TG are installed flange to flange (diagram #1); the flues are retained by screwing a flange band over the mating flanges (diagram #2); the joint is then wrapped with insulation (diagram #3); and the joint is covered by a closure band (diagram #4). See **FIG. 16**.

2. Attach the elbow to the chimney pipe or other support part and twist to lock. Using the offset chart, add chimney sections between elbows. A support band (TGSB) is required at the upper elbow of the pair to support the load, as shown in **FIG. 18**. Attach the upper elbow to bring chimney back to vertical.

**Offset combinations: see Tables 3 and 3A and illustration, FIG. 17.**

# FLASHING INSTALLATION

1. Continue the TG chimney to the roof. Cut the roof opening, centered over the chimney. A 1-1/2 inch for 6" - 8" diameters and 2 inch for 10" - 18" diameters, airspace around the chimney is required as it penetrates the roof. The size of hole in the roof will vary depending on the roof pitch. See note for **Table 1** regarding special 8TG clearances.

2. Install the next TG chimney section through the roof. See **FIG. 19**. For 12", 14", 16" and 18" chimneys only, install a radiation shield (TGRSH) over the chimney section so that the shield straps can be temporarily bent over the roof to hold in place. After installing the flashing, these straps will be attached to the flashing as shown in **FIG. 20**.

**NOTE:** If your roof is already shingled, be sure to slide the upper edge under the shingles to prevent leakage.

3. Install a bead of caulk around the pipe at the top edge of the flashing. Wrap the storm collar around the pipe and imbed the edge in the caulk to prevent leakage around the pipe.

4. Continue to install pipe sections until proper termination height is reached. See termination section.

**TABLE 3**

6", 7", 8", 10", AND 12" DIAMETER OFFSET TABLE					
A		15° Angle		30° Angle	
Length	No. Pcs.	B	C	B	C
0	0	18-7/16"	2-1/4"	20-3/16"	5"
6"	1	22-13/16"	3-3/8"	24-1/16"	7-1/4"
12"	1	28-5/8"	4-15/16"	29-1/4"	10-1/4"
18"	1	34-3/8"	6-1/2"	34-7/16"	13-1/4"
24"	1	40-3/16"	8-1/16"	39-5/8"	16-1/4"
30"	2	44-1/2"	9-1/4"	43-1/2"	18-1/2"
36"	1	51-3/4"	11-3/16"	50-1/16"	22-1/4"
42"	2	56-1/8"	12-3/8"	53-15/16"	24-1/2"
48"*	1	63-3/8"	14-1/4"	60-7/16"	28-1/4"
54"*	2	67-3/4"	15-7/16"	64-3/8"	30-1/2"
60"*	2	73-1/2"	17"	69-1/2"	33-1/2"
66"*	2	79-11/16"	18-1/2"	74-3/4"	36-1/2"
72"*	2	85-1/2"	20-1/16"	79-15/16"	39-1/2"
78"*	3	89-7/16"	21-1/4"	83-13/16"	41-3/4"
84"*	2	96-11/16"	23-3/16"	90-5/16"	45-1/2"
90"*	3	102-3/8"	24-3/8"	94-3/16"	47-1/2"
96"*	2	108-1/4"	26-5/16"	100-11/16"	51-1/2"

\*48" length not available for 10" and 12" diameters

**TABLE 3A**

14", 16" AND 18" DIAMETER OFFSET TABLE					
A		15° Angle		30° Angle	
Length	No. Pcs.	B	C	B	C
0	0	25-5/8"	3-3/8"	29"	7-3/4"
9"	1	34-3/4"	5-3/4"	36-3/4"	12-1/4"
18"	1	43"	8-1/8"	44-5/8"	16-3/4"
27"	2	51-3/4"	10-3/8"	52-3/8"	21-1/4"
30"	1	54-5/8"	11-1/4"	55"	22-3/4"
36"	2	60-3/8"	12-3/4"	60-1/4"	25-3/4"
39"	2	63-1/4"	13-1/2"	62-3/4"	27-1/4"
42"	1	66-1/4"	14-3/8"	65-3/8"	28-3/4"
48"	2	72"	15-7/8"	70-1/2"	31-3/4"
57"	3	80-5/8"	18-1/8"	78-3/8"	36-1/4"
60"	2	83-5/8"	19"	81"	37-3/4"
72"	2	95-1/4"	22-1/8"	91-3/8"	43-3/4"
84"	2	106-3/4"	25-1/4"	101-7/8"	49-3/4"
90"	3	112-5/8"	26-7/8"	106-7/8"	52-3/4"

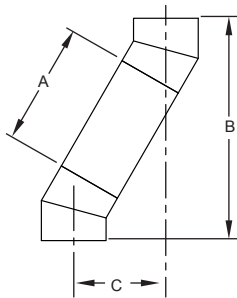

**FIG. 17**

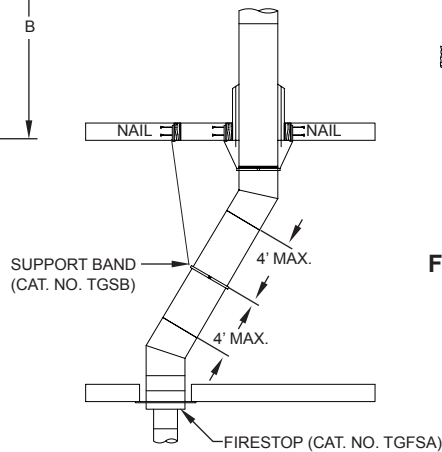

**FIG. 18**

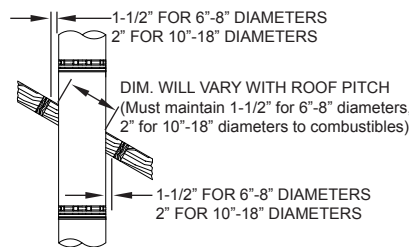

**FIG. 19**

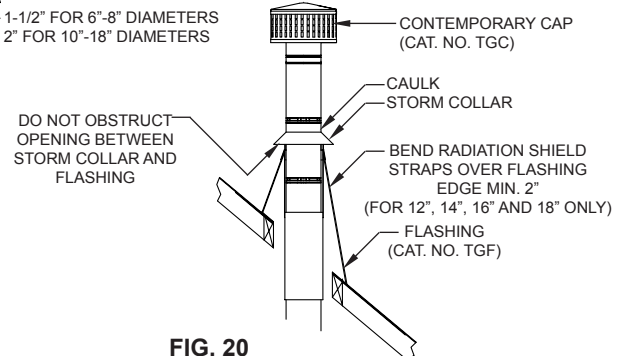

**FIG. 20**

# TERMINATION

Major building codes specify a minimum chimney height above the roof top. These specifications are summarized in what is known as the "Ten Foot Rule". This rule states:

If the horizontal distance from the side of the chimney to the peak of the roof is 10 feet or less, the top of the chimney must be at least 2 feet above the peak of the roof, but never less than 3 feet in overall height above the highest point where it passes through the roof (FIG. 21).

If the horizontal distance from the side of the chimney to the peak of the roof is more than 10 feet, a chimney height reference point is established on the surface of the roof a distance of 10 feet from the side of the chimney in a horizontal plane. The top of the chimney must be at least 2 feet above this reference point, but never less than 3 feet in height above the highest point where it passes through the roof (FIG. 22)

These chimney heights are necessary in the interest of safety and do not ensure smoke free operation. Trees, buildings, adjoining roof lines, adverse wind conditions, etc., may create need for a taller chimney should smoking occur.

Additional support is required above the roof if the chimney height exceeds four (4) feet.

Select the proper support for your application, using either a roof brace (FIG. 23) or a support band with guy wires (FIG. 24)

## TG ROOF BRACE INSTALLATION

1. Form the attachment band around the chimney, and clamp in place at the desired height using bolt and nut provided.
2. Loosely attach the support legs to the bolts on the attachment band using hardware provided.
3. Position the support legs as shown in FIG. 23. The length of the support legs can be adjusted by loosening the bolt on the leg clamp.
4. Secure legs to roof using screws provided. Seal screw holes to prevent roof leaks.
5. Tighten all hardware.

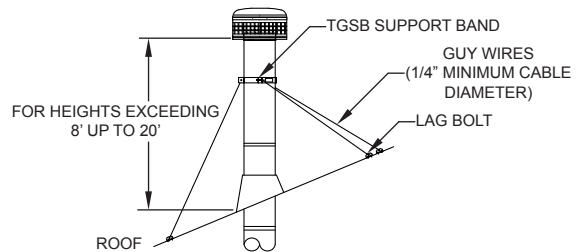
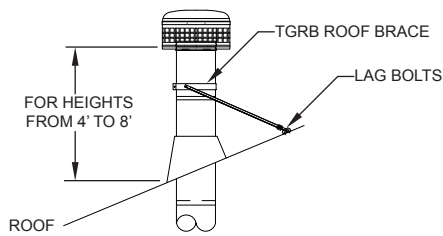
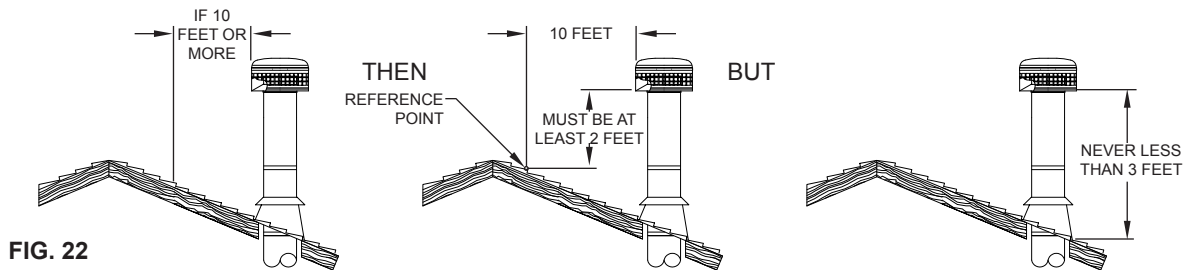
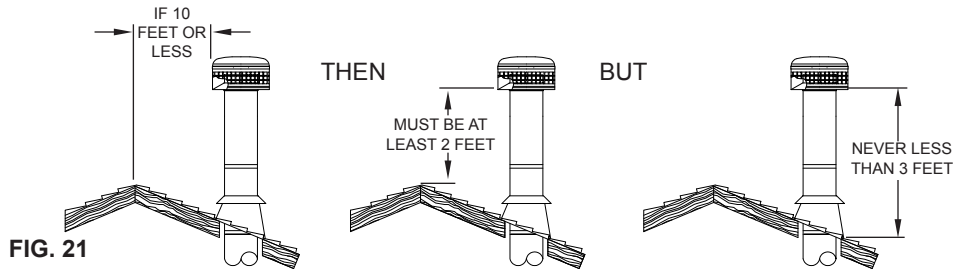

P.O. Box 1138 • WICHITA, KANSAS 67201  
 (316) 943-2351 • FAX (316) 943-2717  
 info@mtlfab.com • www.mtlfab.com