

iT1200 Ice Cube Machine

Models

- IDT1200A
 IYT1200A
 IDT1200W
 IYT1200W
 IDT1200N
 IYT1200N



Indigo NXT iT1200 ice machine on a D570 bin

Designed for operators who know that ice is critical to their business, the Indigo NXT Series ice machine's preventative diagnostics continually monitor itself for reliable ice production. Improvements in cleanability and programmability make your ice machine easy to own and less expensive to operate.

- **New levels of Performance** – Showcasing an average of 5% lower energy consumption and a 22% reduction in condenser water usage. This translates into lower cost of ownership over the life of your machine.
- **easyTouch[®] Display** - New icon based touch screen takes the guess work out of owning and operating an ice machine.
- **Programmable Ice Production** – Now its super easy to program your ice machine to be off at certain times of the day to save money with fluctuating electrical rates. Also programmable by daily ice production volume.
- **Easy to Clean Foodzone** – Hinge front door swing out for easy access. Removable water-trough, distribution tube, curtain, water probe and water pump for fast and efficient cleaning. Selected components are made with AlphaSan[®] antimicrobial.
- **Intelligent Diagnostics** – Provides 24 hour preventative maintenance and diagnostic feedback for trouble free operation.
- **Acoustical Ice Sensing Probe** – Unique patented technology allows for reliable operation in challenging water conditions and environments
- **DuraTech[®] Exterior** – Provides superior corrosion resistant above stainless steel. Innovative clear-coat resists fingerprints and dirt making it easier to keep clean.
- Available **LuminIce[®] II Growth Inhibitor** – Controls the growth of bacteria and yeast within the Food zone keeping the machine cleaner longer. A new indicator in the display keeps you abreast of the operational status.

Ice Machine Electric

208-230/60/1 standard
(208-230/60/3 also available)

Minimum circuit ampacity:

Air-cooled:	14.2 1ph	8.6 3ph
Water-cooled:	13.4 1ph	7.9 3ph
Remote:	11 1ph	9.2 3ph

Maximum fuse size:

Air-cooled:	20 1ph	15 3ph
Water-cooled:	20 1ph	15 3ph
Remote:	15 1ph	15 3ph



Specifications

BTU Per Hour:
16,200 (average),
and 19,100 (peak)

Refrigerant:
R410A CFS - Free
Lowers global warming
by 48%

Operating Limits:

- Ambient Temperature Range:
40° to 110°F (4.4° to 43.3°C)
Water Temperature Range:
40° to 90°F (4.4° to 32.2°C)
- Water Pressure Ice Maker
Water In:
Min. 20 psi (137.9 kPa)
Max. 80 psi (551.1 kPa)

Ice Shape

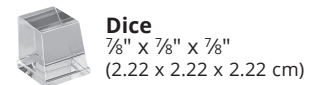
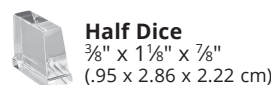

COMPANY WITH
QUALITY SYSTEM



iT1200 on D-570 Storage Bin

- (A) Electrical Entrance (2) Options
- (B) 3/8" (0.95 cm) F.P.T. Water Condenser Inlet (water-cooled units)
- (C) 1/2" (1.27 cm) F.P.T. Water Condenser Outlet (water-cooled units)
- (D) 1/2" (1.27 cm) Auxillary Base Drain Socket
- (E) 3/8" (0.95 cm) F.P.T. Ice Making Water Inlet
- (F) 1/2" (1.27 cm) F.P.T. Ice Making Water Drain
- (G) 3/4" (1.91 cm) Bin Drain

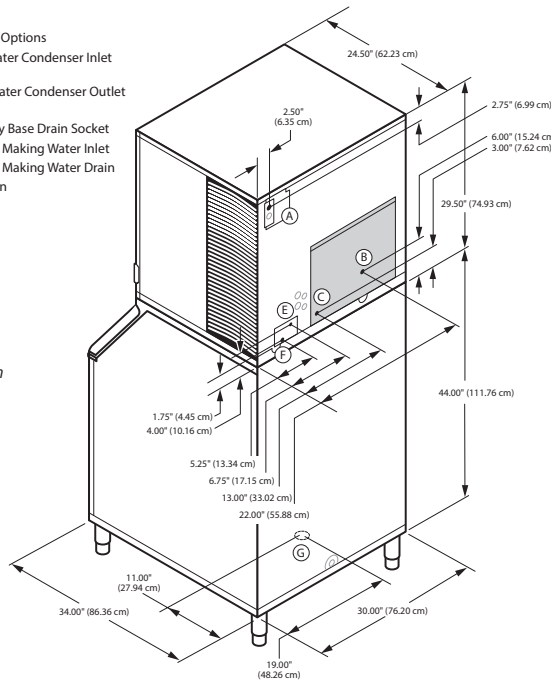

Installation Note
Minimum installation clearance:
Top/side: 12" (30.50 cm) Back is 5" (12.7 cm)

Space-Saving Design



	iT1200 D-570	iT1200 D-970
Height	79.50" 201.93 cm	79.50" 201.93 cm
Width	30.00" 76.20 cm	48.00" 121.92 cm
Depth	34.00" 86.30 cm	34.00" 86.30 cm
Bin	543 lbs.	882 lbs.
Storage	241.1 kgs.	400.1 kgs.

Height includes adjustable bin legs 6.00" to 8.00", (15.24 to 20.32 cm) set at 6.00" (15.24 cm).
Bin capacity is based on 90% of the volume x 33 lbs/ft³ average density of ice.

* K00458 bin adapter required

Specifications

	Model	Ice Shape	Ice Production 24 Hours		Power Usage kWh/100 lbs. @90°Air/70°F		Potable Water Usage/100 lbs. 45.4 kgs. of Ice
			70°Air/ 50°F Water	90°Air/ 70°F Water	1 Ph	3 Ph	
AIR COOLED	IDT1200A	dice	1196 lbs.	950 lbs.	4.80	4.80	19.9 Gal. 75.3 L
			542 kgs	431 kgs			
	IYT1200A	half-dice	1213 lbs.	950 lbs.	4.75	4.75	19.9 Gal. 75.3 L
			550 kgs	431 kgs			
WATER COOLED	IDT1200W	dice	1078 lbs.	900 lbs.	4.16	4.16	19.9 Gal. 75.3 L
			489 kgs	408 kgs			
	IYT1200W	half-dice	1138 lbs.	965 lbs.	4.00	4.00	19.9 Gal. 75.3 L
			516 kgs.	438 kgs			
* Water-cooled Condenser Water Usage / 100 lbs. /45.4 kgs. Of Ice: 140 gal/ 530 L. *Water-cooled models are excluded from ENERGY STAR qualification.							
REMOTE COOLED	IDT1200N	dice	1127 lbs.	960 lbs.	4.40	4.40	19.9 Gal. 75.3 L
			511 kgs	435 kgs			
	IYT1200N	half-dice	1215 lbs.	1000 lbs.	4.40	4.40	19.9 Gal. 75.3 L
551 kgs			454 kgs				

Order Separately ice storage bin for all units, JCT1200 vertical condenser order separately for Remote cooled units

Accessories

LuminIce[®] II Growth Inhibitor
reduces yeast and bacteria growth for a cleaner ice machine.



External Scoop holder
Protect the ice scoop with the NSF approved versatile scoop holder.



Arctic Pure[®] Water Filters
Reduces sediment and chlorine odors for better tasting ice.



iAuCS[®]
schedules and performs routine ice machine cleaning automatically.



Welbilt reserves the right to make changes to the design or specifications without prior notice.