

QuietQube[®] iF1800C Remote Ice Cube Machine

Air-Cooled Ice Cube Machine with Patented CVD Technology[®]

Air-Cooled Ice Cube Machine with Patented CVD Technology[®] QuietQube[®] iF1800C Remote Ice Cube Machine

Model

- IDF-1800C IYF-1800C



IDF-1800C Ice Cube Machine - 115V



CVDF1800 Condensing Unit 208 V



IDF-1800C Ice Machine on a D-970 Bin



Two IDF-1800C Ice Machines on a F-1650 Bin

QuietQube Series Remote System consists of a remote condensing unit, interconnecting refrigerant lines, ice machine head section along with an ice storage bin, countertop dispenser, or floor dispenser. All ordered separately. QuietQube ice machine with CVD condensing unit is designed as a Manitowoc system and cannot be used with any other ice machine or remote condenser brand.

- **Space-Saving Design** – Up to 1,725 lbs. (782 kgs.) daily ice production and only 30" (76.20 cm) wide.
- **Quiet Operation** - eliminates most noise from the refrigeration system. Promotes a relaxing atmosphere.
- **easyTouch[®] Display** - New icon based touch screen takes the guess work out of owning and operating an ice machine.
- **Programmable Ice Production** – Now its super easy to program your ice machine to be off at certain times of the day to save money with fluctuating electrical rates. Also programmable by daily ice production volume.
- **Easy to Clean Foodzone** – Hung door for easy access. Removable water-trough, distribution tube, splash guard, water probe and water pump for fast and efficient cleaning. Selected components are made with AlphaSan[®] antimicrobial.
- **Intelligent Diagnostics** – Provides 24 hour preventative maintenance and diagnostic feedback for trouble free operation.
- **Acoustical Ice Sensing Probe** – Unique patented technology allows for reliable operation in challenging water conditions and environments
- **DuraTech[®] Exterior** – Provides superior corrosion resistant above stainless steel. Innovative clear-coat resists fingerprints and dirt making it easier to keep clean.
- **Available LuminIce[®] II Growth Inhibitor** – Controls the growth of bacteria and yeast within the Food zone keeping the machine cleaner longer. A new indicator in the display keeps you abreast of the operational status.

COMMERCIAL WARRANTY		
ICE MAKER	EVAPORATOR	COMPRESSOR
3	5	5
YEAR	YEAR	YEAR PARTS
PARTS AND LABOR		3 YEAR LABOR

Ice Shape



Half Dice
 $\frac{3}{8}$ " x $1\frac{1}{8}$ " x $\frac{7}{8}$ "
 (.95 x 2.86 x 2.22 cm)



Dice
 $\frac{7}{8}$ " x $\frac{7}{8}$ " x $\frac{7}{8}$ "
 (2.22 x 2.22 x 2.22 cm)





iF1800C Ice Machine

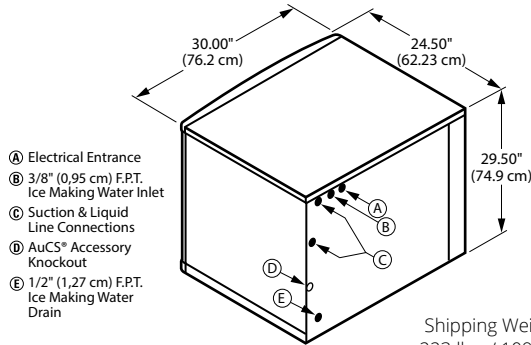

Shipping Weight:
223 lbs. / 109 kgs.

Specifications

Operating Limits:

- Ambient Temperature Range: 40° to 110° F (4.4° to 43.3° C)
- Water Temperature Range: 40° to 90° F (4.4° to 32.2° C)
- Water Pressure Ice Maker Water In:
Min. 20 psi (137.9 kPa)
Max. 80 psi (551.1 kPa)

Ice Machine Electric

115/60/1 standard. (230/50/1 also available, consult factory.)
Total Amps: 1.1
Max. fuse size: 15 amps
 HACR-type circuit breakers can be used in place of fuses.

Remote Air-cooled Ice Machine

Model	Ice Shape	Ice Production 24 Hours		Power kWh/ 100 lbs @ 90°/70°F*
		70°Air/ 50°F Water	90°Air/ 70°F Water*	
IDF-1800C	dice	1,715 lbs.	1,375 lbs.	4.74
		778 kgs.	624 kgs.	
IYF-1800C	half-dice	1,725 lbs.	1,470 lbs.	4.60
		782 kgs.	667 kgs.	
Water usage/100 lbs./45.4 kgs. of Ice				
Potable Water*: 18 gallons, 68 liters				



*Ratings Certified in Accordance with AHRI Standard 810.

Ice machine for use with ice storage bin or ice dispenser and CVD condensing unit all ordered separately.

kWh per 100 lbs. is total power of ice machine and condensing unit. Ice machine is 1 ph only. Condensing unit is 1 ph or 3 ph.

Accessories

LuminIce® II Growth Inhibitor reduces yeast and bacteria growth for a cleaner ice machine.



AuCS® Automatic Cleaning System purchased as an option and installed in the field.



CVDF1800 Remote Condensing Unit

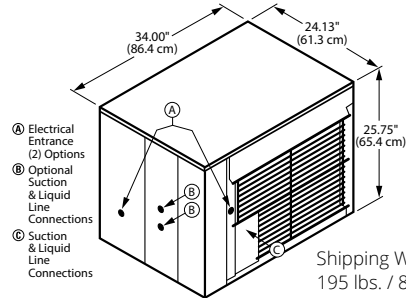

Shipping Weight:
195 lbs. / 88 kgs.

Condensing Unit Electric

208-230/60/1 standard. 208-230/60/3. HACR-type circuit breakers can be used in place of fuses.

Note: QuietQube ice machine power supply is wired independent of CVD condensing unit.

Min. circuit ampacity 25 1ph / 20 3ph
Max. fuse size: 40 amps 1ph / 25 amps 3ph
 HACR-type circuit breakers can be used in place of fuses.

Operating Limits:

- Ambient Temperature Range: -20° to 130° F (-29° to 54° C)

BTU Per Hour: 27,000 (average) 31,000 (peak)
Compressor: Nominal rating: 2.5 HP

Installation Information and Dimensions:

- Maximum Line Length — 100' (30.5 m).*
- Maximum Vertical Rise* — 35' (10.7 m) above ice machine.
- Maximum Vertical Drop — 15' (4.5 m) below ice machine.



*A rise over 20' (6 m) requires S-Trap Kit K-00166 - ordered separately.

Standard Interconnecting Tubing

Model	Line Length		Weight	
	ft.	m.	lbs.	kgs.
RC-20	20	6	14	6
RC-30	30	9	20	9
RC-50	50	15	31	14

Welbilt reserves the right to make changes to the design or specifications without prior notice.