

# SINGLE-ZONE VERTICAL AIR HANDLING UNIT ENGINEERING MANUAL



LV181HV4 (18,000 Btu/h)  
LV241HV4 (24,000 Btu/h)



LV361HV4 (36,000 Btu/h)



LV420HV (42,000 Btu/h)  
LV480HV (48,000 Btu/h)

**Single-Zone Vertical Air  
Handling Unit System**  
**18,000 - 48,000 Btu/h**

## **PROPRIETARY DATA NOTICE**

**This document, as well as all reports, illustrations, data, information, and other materials are the property of LG Electronics U.S.A., Inc., and are disclosed by LG Electronics U.S.A., Inc. only in confidence.  
This document is for design purposes only.**





A summary list of safety precautions is on page 3.

**For more technical materials such as submittals, catalogs, installation, owner's, and service manuals, visit [www.lghvac.com](http://www.lghvac.com).**

# TABLE OF CONTENTS

Unit Nomenclature.....	4
LG Air Conditioner Technical Solution (LATS) .....	5-6
<b>Vertical Air Handling Unit Product Data .....</b>	<b>7-55</b>
<i>Mechanical Specifications .....</i>	8-9
<i>General Data .....</i>	10-13
<i>Electrical Data .....</i>	14
<i>Functions, Controls, and Options .....</i>	15-16
<i>Dimensions .....</i>	17-20
<i>Acoustic Data .....</i>	21-31
<i>Refrigerant Flow Diagrams.....</i>	32-33
<i>Wiring Diagrams, Dip Switch Settings.....</i>	34-41
<i>Electrical Connections.....</i>	42-46
<i>External Static Pressure and Air Flow Ranges.....</i>	47-51
<i>Accessories .....</i>	52-55
<b>Vertical Air Handling Unit Performance Data .....</b>	<b>56-74</b>
<i>Cooling Capacity Data.....</i>	57-61
<i>Heating Capacity Data.....</i>	62-66
<i>Maximum Heating Capacity Data.....</i>	67-71
<i>Equipment Selection Procedure.....</i>	72-74
<b>Vertical Air Handling Unit Application Guidelines.....</b>	<b>75-86</b>
<i>Placement Considerations.....</i>	76-79
<i>Clearances .....</i>	80-82
<i>Installing Outdoor Unit Indoors.....</i>	83-84
<i>Refrigerant Piping Design.....</i>	85-86

## TABLE OF SYMBOLS

 <b>DANGER</b>	<i>This symbol indicates an imminently hazardous situation which, if not avoided, will result in death or serious injury.</i>
 <b>WARNING</b>	<i>This symbol indicates a potentially hazardous situation which, if not avoided, could result in death or serious injury.</i>
 <b>CAUTION</b>	<i>This symbol indicates a potentially hazardous situation which, if not avoided, may result in minor or moderate injury.</i>
<b>Note:</b>	<i>This symbol indicates situations that may result in equipment or property damage accidents only.</i>
	<i>This symbol indicates an action that must not be performed.</i>

# UNIT NOMENCLATURE

## Indoor Units and Outdoor Units

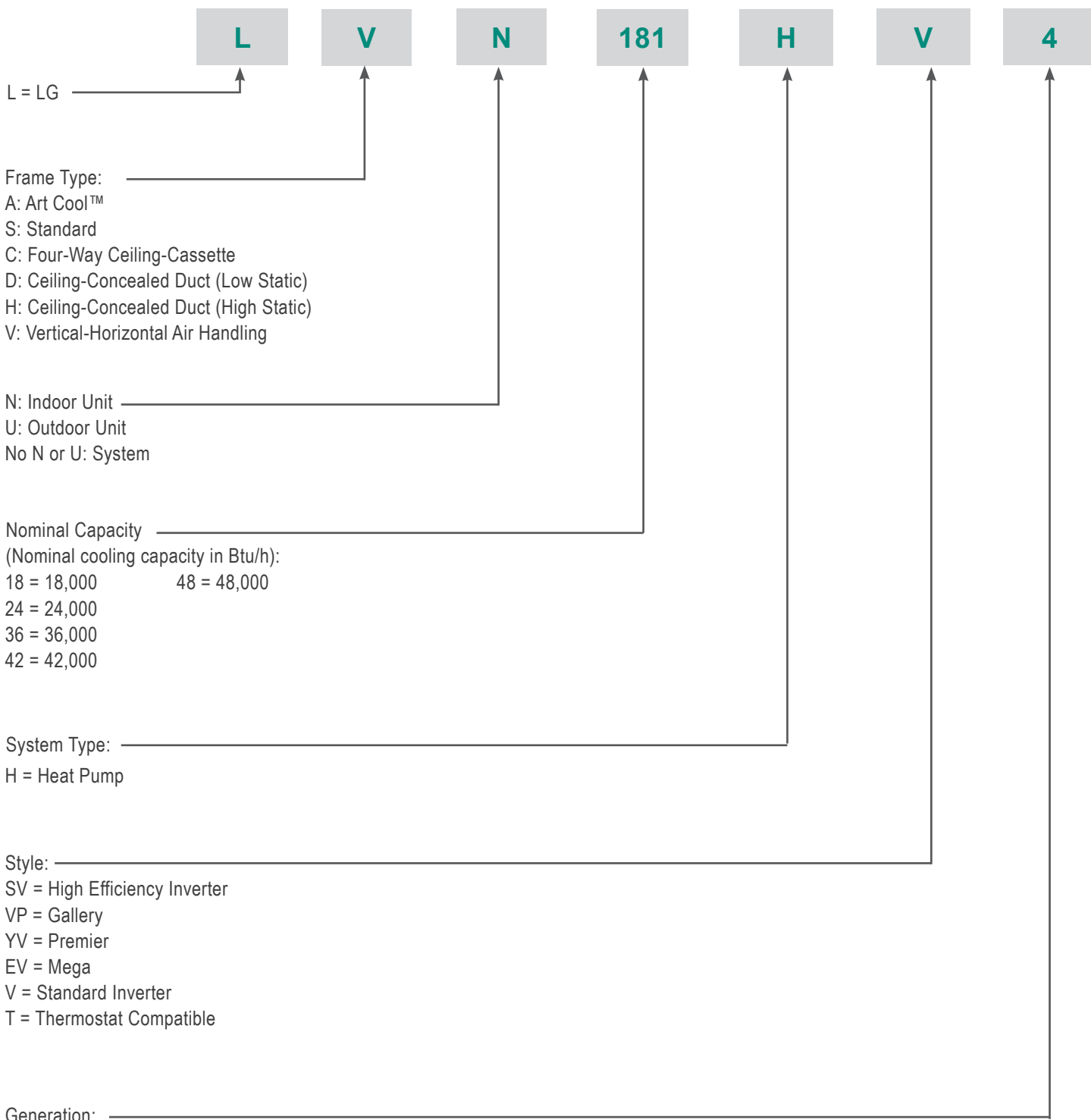

# LG AIR CONDITIONER TECHNICAL SOLUTION (LATS)

## LG Air Conditioner Technical Solution (LATS) Software

A properly designed and installed refrigerant piping system is critical to the optimal performance of LG air-conditioning systems. To assist engineers, LG offers, free of charge, LG Air Conditioner Technical Solution (LATS) software—a total design solution for LG air conditioning systems. Contact your LG Rep for the best software program for your application.

### Note:

To reduce the risk of designing an improper applied system or one that will not operate correctly, LG requires that LATS software be used on all projects.

### Formats

LATS is available to LG customers in three user interfaces: LATS HVAC, LATS CAD2, and LATS Revit. All three LATS formats are available through [www.myLGHVAC.com](http://www.myLGHVAC.com), or contact an LG Sales Representative.

**LATS HVAC** is a Windows®-based application that aids engineers in designing LG Variable Refrigerant Flow (VRF), Multi F / Multi F MAX, Single-Zone, and Energy Recovery Ventilator (ERV) systems.

\*Windows® is a registered mark of Microsoft® Corporation.

**LATS CAD2** combines the LG LATS program with AutoCAD® software\*\*. It permits engineers to layout and validate LG Multi V Variable Refrigerant Flow (VRF), Multi F / Multi F MAX, Single-Zone, and Energy Recovery Ventilator (ERV) systems directly into CAD drawings.

**LATS Revit** integrates the LG LATS program with Revit® software\*\*. It permits engineers to layout and validate Multi V VRF systems directly into Revit drawings.

\*\*AutoCAD® and Revit® are both registered marks of Autodesk, Inc.

### Features

All LG product design criteria have been loaded into the program, making LATS simple to use: double click or drag and drop the component choices. Build systems in Tree Mode where the refrigerant system can be viewed. Switch to a Schematic diagram to see the electrical and communications wiring.

LATS software permits the user to input region data, indoor and outdoor design temperatures, modify humidity default values, zoning, specify type and size of outdoor units and indoor units, and input air flow and external static pressure (ESP) for ducted indoor units.

The program can also:

- Import building loads from a separate Excel file.
- Present options for outdoor unit auto selection.
- Automatically calculate component capacity based on design conditions for the chosen region.
- Verify if the height differences between the various system components are within system limits.
- Provide the correct size of each refrigerant piping segment and LG Y-Branches and Headers.
- Adjust overall piping system length when elbows are added.
- Check for component piping limitations and flag if any parameters are broken.
- Factor operation and capacity for defrost operation.
- Calculate refrigerant charge, noting any additional trim charge.
- Suggest accessories for indoor units and outdoor units.
- Run system simulation.

### Note:

Features depend on which LATS program is being used, and the type of system being designed.

Figure 1: Example of LATS CAD2.

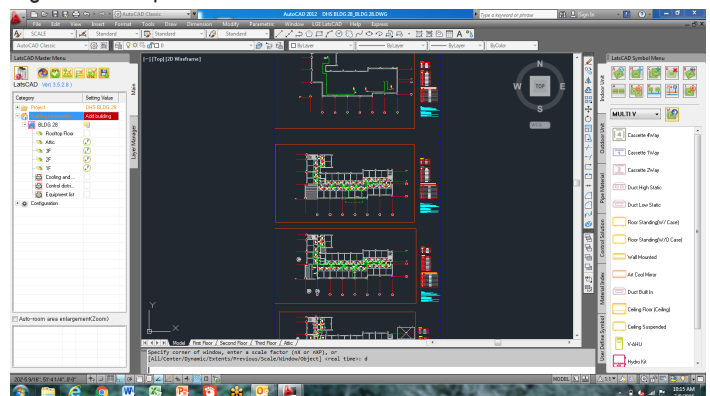

# LG AIR CONDITIONER TECHNICAL SOLUTION (LATS)

## LATS Generates a Complete Project Report

LATS software also generates a report containing project design parameters, cooling and heating design data, system component performance, and capacity data. The report includes system combination ratio and refrigerant charge calculations; and provides detailed bill of material, including outdoor units, indoor units, control devices, accessories, refrigerant pipe sizes segregated by building, by system, by pipe size, and by pipe segments. LATS can generate an Excel GERP report that can be imported into the LG SOPS pricing and ordering system.

## Proper Design to Install Procedure

LG encourages a two report design-to-install-procedure. After the design engineer determines building / zone loads and other details, the engineer opens the LATS program and inputs the project's information. When the design is complete, the "Auto Piping" and "System Check" functions must be used to verify piping sizes, limitations, and if any design errors are present. If errors are found, engineers must adjust the design, and run Auto Piping and System Check again. When the design passes the checks, then the engineer prints out a project "Shop Drawing" (LATS Tree Diagram) and provides it to the installing contractor. The contractor must follow the LATS Tree Diagram when building the piping system, but oftentimes the design changes on the building site:

- Architect has changed location and/or purpose of room(s).
- Outdoor unit cannot be placed where originally intended.
- Structural elements prevent routing the piping as planned.
- Air conditioning system conflicts with other building systems (plumbing, gas lines, etc.).

The contractor must mark any deviation from the design on the Shop Drawing, including as-built straight lines and elbows. This "Mark Up" drawing must be returned to the design engineer or Rep, who must input contractor changes into the LATS file. (Copy the original LATS software file, save and rename as a separate file, and modify all piping lengths by double-clicking on each length and editing information.) Like the shop drawing, the Auto Piping and System Check must also be run on this new "As Built" drawing. The design engineer or Rep must then provide the final As Built file to the contractor. The Mark Up version must be compared to the As Built version for the following:

- Differences in pipe diameter(s). If incorrect diameters have been installed, the piping must be changed out. If pipe diameters have changed, check to see if Y-Branches will also need to be changed.
- Changes to outdoor unit and indoor unit capacities. Capacities changes may impact line length changes.
- Additional refrigerant charge quantity ("Trim Charge"). Trim charge will change if piping lengths and diameters change. The As Built version must reflect installed piping lengths to ensure correct trim charge.

All documents submitted by the contractor, as well as the Shop Drawing and the As Built Drawing files must be provided for commissioning purposes. Model and serial numbers for all system components must also be submitted. If the steps previously detailed are not followed, and all documents are not provided to the LG Commissioner, the project runs the risk of not being commissioned and voiding any limited warranty LG offers on the equipment.

Figure 2: Example of a LATS Tree Diagram.

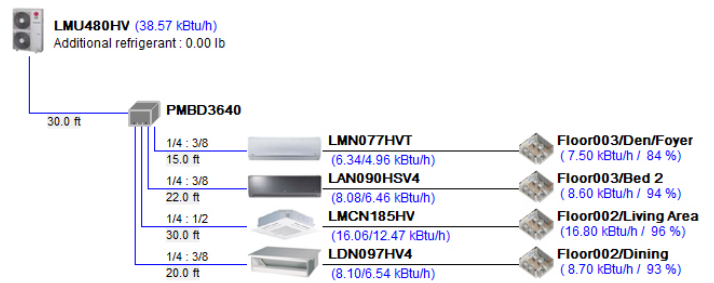

# VERTICAL AIR HANDLING UNIT PRODUCT DATA

**Mechanical Specifications on page 8**

**General Data on page 10**

**Electrical Data on page 14**

**Functions, Controls, and Options on page 15**

**Dimensions on page 17**

**Acoustic Data on page 21**

**Refrigerant Flow Diagrams on page 32**

**Wiring Diagrams on page 34**

**Electrical Connections on page 42**

**External Static Pressure and Airflow Ranges on page 47**

**Accessories on page 52**

# MECHANICAL SPECIFICATIONS

## Casing

The unit is designed to operate in vertical up flow, down flow (requires conversion kit sold separately), horizontal left, and horizontal right configurations.

Supply air exits from the top and return air enters from the bottom for a vertical up flow configuration. Return air opening is from the top for the vertical down flow configuration. Return air opening is from right end or left end when in horizontal configuration.

The airflow circulation of the supply air and return air is reversed in a vertical down flow configuration. Return air plenum sub-base is to be field provided. Supply air opening has a male flange for duct connection.

The unit case is made of 22-gauge coated metal and the external surfaces are finished with a high gloss baked enamel finish. Finish color is "morning fog" (medium beige). Cold surfaces are galvanized steel.

The cold surfaces of the case are internally insulated with ½ inch foil faced, polystyrene fiber insulation. The inside surface of the fan assembly door access panel is treated with ½ inch polystyrene fiber insulation, encapsulated on both sides, and sealed along the edges with a reinforced foil-faced covering to prevent deterioration caused by panel removal.

All access panels are provided with gasket seals to minimize air leakage. The unit case is designed to accept an internal, optional, LG electric strip heater. The unit bears the CSA label. Unit breaker, fuses, and / or disconnect are provided by others.

## Fan Assembly and Control

The indoor unit has an integral fan assembly consisting of a galvanized steel housing and a forward-curved fan wheel. The direct drive fan/motor assembly is mounted on rubber grommets isolating the rotating assembly from the fan housing.

The NJ (18K, 24K, and 36K) chassis is equipped with factory programmed ECM (Electronically Commutated Motor) to deliver constant CFM regardless of external static pressure. The fan motor for NK (42K and 48K) is equipped with a Brushless Digitally-Controlled design (BLDC) fan motor, having permanently lubricated and sealed ball bearings. The fan motor includes thermal, overcurrent and low RPM protection.

The fan/motor assembly is mounted on vibration attenuating rubber grommets. The fan impeller is statically and dynamically balanced. Fan speed of NK chassis is controlled using a microprocessor-based direct digital control algorithm that provides a minimum of a high fan speed in cooling thermal ON and low fan speed in cooling thermal OFF, high fan speed in heating thermal ON and fan off in heating thermal OFF.

The fan speeds can be field adjusted between low, medium, and high speeds. DIP switch settings will allow the fan to run constantly during defrost or oil return modes.

No setting is required for NJ chassis; fan speed changes automatically to maintain programmed air flow settings as the static pressure changes. Each setting for NK chassis can be field adjusted from the factory setting (RPM/ESP).

Being a Constant Air Volume (CAV) unit, the NJ (18k, 24K, 36K) chassis does not require any field adjustment to change the ESP settings. The NK (42K and 48K) chassis comes with factory setting that provides delivery of air volume against an external static pressure of up to 0.9" in-wg.

## Air Filter

The unit comes with a filter rack sized to hold a field-provided 16" x 20" x 1" (NJ frame) or 24" x 20" x 1" (NK frame) filter cartridge. The filter rack is equipped with guides that keep the filter centered in the rack. Filter service access is from the front of the unit without removing the coil or fan area access panels. Filter access door is provided with thumb screws that can be removed.

## Optional Auxiliary Electric Heat Module(s)

LG optional electric heat modules are designed for field installation in the reheat position. The electric heat module is provided with heating elements, contactors, relays, high temperature safety switch, and interconnecting control wiring harness with a quick connect plug for easy connection to the air handling unit control board. Auxiliary heat modules are available in nominal capacities of 3, 5, 8, 10, 15, and 20 kW.

The NJ chassis is compatible with 3,5,8,10 kW auxiliary electric heater and the NK chassis is compatible with 3,5,8,10,15,20 kW auxiliary electric heater.

Heating elements are powered from a field provided separate power source. 3kW through 10 kW modules are powered from a single power wire. The 15kW and 20 kW modules are powered from two power wires. Heating module breakers, fuses, and / or disconnects are to be field provided.

The optional electric heater when used with the provided simple controller or a 3rd party thermostat (via dry contact connection), will have automatic heating operation based on the internal logic. If manual heater operation is intended, an LG Programmable controller is required.

## Microprocessor Control

The indoor unit is provided with an integrated control panel with built-in dry contact to communicate with the outdoor unit. All unit operation parameters are stored in non-volatile memory resident on the unit microprocessor. The microprocessor controls space temperature through using the value provided by temperature sensors within the indoor unit. A field-supplied communication cable must be installed to connect the indoor unit(s) to the outdoor unit.



# MECHANICAL SPECIFICATIONS

## Compressors

The 9,000 ~ 24,000, as well as the 42,000 and the 48,000 Btu/h outdoor units are equipped with one hermetically sealed, digitally controlled, inverter-driven twin rotary compressor to modulate capacity (modulation in 1 Hz increments).

The 36,000 Btu/h outdoor unit is equipped with one hermetically sealed, digitally controlled, inverter-driven scroll compressor to modulate capacity (modulation in 1 Hz increments).

Teflon coated bearings, overcurrent protection, and vibration isolation are integrated with the compressor.

### Frequency ranges for the 9,000 ~ 24,000 Btu/h outdoor units are:

9k Btu/h = 20 Hz to 100 Hz

12k Btu/h = 20 Hz to 100 Hz

18 Btu/h = 15 to 80 Hz Cooling; 15 to 100 Hz Heating

24k Btu/h = 15 to 80 Hz Cooling; 15 to 100 Hz Heating

### Frequency ranges for the 36,000 and 42,000 Btu/h outdoor units are:

36k Btu/h = 15 to 120 Hz Cooling; 15 to 130 Hz Heating

42k Btu/h = 20 to 100 Hz

48K Btu/h = 20 to 100 Hz

## Controls

An LG wired controller can be used with the indoor unit, but is sold separately. Communication cable from the outdoor unit to the indoor unit must be a minimum of 14 AWG, four (4) conductor, shielded or unshielded (if shielded, must be grounded to chassis at ODU only) and must comply with applicable local and national codes.

The indoor unit has a built-in dry contact for a field supplied 3rd party thermostat. An optional Wi-Fi module is available as an additional accessory for use with LG's SmartThinQ app on a smart device.

## Condensate

The unit is designed for gravity draining of condensate.

## Condensate Drain Pan

The condensate drain pan is constructed of HIPS (high impact polystyrene resin).

## Coil

The indoor unit coil is constructed with grooved design copper tubes with slit coil fins, 3 rows, 18 fins per inch. For 18k and 24k units, there are 2 rows; for 36k, 42k, and 48k units, there are 3 rows. There are 18 fins per inch for all units.

## Controls Features

- Inverter (Variable speed fan)
- Child lock function
- Auto changeover
- Auto restart operation
- Dehumidifying function
- Two thermistor control
- Group control
- External static pressure control
- Self-diagnostics function

## Vertical Down Flow Configuration

NJ and NK frames come factory configured for vertical up flow. Down flow configuration requires a conversion kit sold separately (model numbers: PNDFJ0 for NJ frame and PNDFK0 for NK frame). The kit contains support brackets for the evaporator coil/drain pan subassembly, addition screws, and a replace front panel to accommodate the coil and drain connections for down flow configuration.

Figure 3: Vertical Air Handling Indoor Unit System (LV181HV4, LV241HV4)



# GENERAL DATA

## Pairing Table

Table 1: Single Zone Vertical Air Handling Unit Pairing Table

Outdoor Unit Model	Indoor Unit Model
<p data-bbox="293 405 407 457">LUU189HV LUU249HV</p> 	<p data-bbox="708 405 967 457">LVN181HV4, LVN241HV4, LVN361HV4 (NJ frame)</p> 
<p data-bbox="293 1010 407 1041">LUU369HV</p> 	

# GENERAL DATA

## Pairing Table

Table 2: Single Zone Vertical Air Handling Unit Pairing Table

Outdoor Unit Model	Indoor Unit Model
<p data-bbox="298 407 412 457">LUU428HV LUU488HV</p> 	<p data-bbox="729 407 956 457">LVN420HV, LVN480HV (NK frame)</p> 

Product Data

# GENERAL DATA / SPECIFICATIONS

Table 3: Vertical Air Handling Unit General Data.

Type	Vertical Air Handling Unit				
System Model (Indoor Unit / Outdoor Unit)	LV181HV4 (LVN181HV4/ LUU189HV)	LV241HV4 (LVN241HV4/ LUU249HV)	LV361HV4 (LVN361HV4/ LUU369HV)	LV420HV (LVN420HV/ LUU428HV)	LV480HV (LVN480HV/ LUU488HV)
Cooling Capacity (Min/Rated/Max) (Btu/h)	7,200 ~ 18,000 ~ 24,000	9,600 ~ 24,000 ~ 30,000	14,400 ~ 36,000 ~ 39,000	17,000 ~ 42,000 ~ 48,000	18,000 ~ 48,000 ~ 53,000
Cooling Power Input <sup>1</sup> (kW)	0.45 ~ 1.35 ~ 3.25	0.58 ~ 2.00 ~ 3.26	1.00 ~ 3.27 ~ 3.60	1.35 ~ 3.80 ~ 5.30	1.40 ~ 4.80 ~ 6.00
EER	13.30	12.0	11.0	11.05	10.00
SEER	19.2	19.5	18.0	17.0	16.5
Heating Capacity (Min / Rated / Max) (Btu/h)	8,000 ~ 20,000 ~ 24,000	10,800 ~ 27,000 ~ 30,000	16,000 ~ 40,000 ~ 43,000	18,000 ~ 47,000 ~ 55,000	19,000 ~ 56,000 ~ 60,000
Heating Power Input <sup>1</sup> (kW)	0.50 ~ 1.73 ~ 2.37	0.65 ~ 2.25 ~ 3.04	1.02 ~ 3.57 ~ 4.40	1.45 ~ 4.00 ~ 5.65	1.50 ~ 5.10 ~ 6.20
COP	3.40	3.52	3.28	3.44	3.22
HSPF	10.4	11.0	10.0	10.0	9.5
<i>Maximum Heating Capacity (Btu/h)</i>					
Outdoor 17°F (DB) / Indoor 70°F (DB)	21,000	26,000	37,350	37,000	40,000
Outdoor 5°F (DB) / Indoor 70°F (DB)	20,500	23,600	35,000	32,000	34,000
Power Input [W] @ Outdoor 5°F (WB)	3,100	3,290	5,620	4,800	5,250
Outdoor -4 °F(DB) / Indoor 70°F (DB)	19,910	20,760	32,220	24,000	26,000
Power Supply V, Ø, Hz	208-230 / 1 / 60				
<i>Outdoor Unit Operating Range</i>					
Cooling (°F DB)	5 to 118				
Optional Wind Baffle Cooling (°F DB)	Yes (-4)				
Heating (°F WB)	-4 to 64				
<i>Indoor Unit Operating Range</i>					
Cooling (°F WB)	57 to 77				
Heating (°F DB)	59 to 81				
<i>Indoor Temperature Setting Range</i>					
Cooling (°F DB)	65 to 86				
Heating (°F WB)	61 to 86				

EEV: Electronic Expansion Valve, IDU: Indoor Unit, ODU: Outdoor Unit. This unit comes with a dry helium charge.

This data is rated 0 ft above sea level, with 24.6 ft of refrigerant line per indoor unit and a 0 ft level difference between outdoor and indoor units.

Cooling capacity rating obtained with air entering the indoor coil at 80°F dry bulb (DB) and 67°F wet bulb (WB); and outdoor ambient conditions of 95°F dry bulb (DB) and 75°F wet bulb (WB).

Heating capacity rating obtained with air entering the indoor unit at 70°F dry bulb (DB) and 60°F wet bulb (WB); and outdoor ambient conditions of 47°F dry bulb (DB) and 43°F wet bulb (WB).

<sup>1</sup> Power Input is rated at high speed. Cooling range can be extended from 5°F down to -4°F using the Low Ambient Wind Baffle Kit (sold separately).

<sup>2</sup> All communication / connection (power) cable from the outdoor unit to the indoor unit

are field supplied and is to be a minimum four-conductor, 14 AWG, stranded, shielded or unshielded (if shielded, it must be grounded to the chassis of ODU only), and must comply with applicable local and national codes.

<sup>3</sup> Take appropriate actions at the end of HVAC equipment life to recover, recycle, reclaim or destroy R410A refrigerant according to applicable regulations (40 CFR Part 82, Subpart F) under section 608 of CAA.

<sup>4</sup> Sound pressure levels are tested in an anechoic chamber under ISO Standard 3745 and are the same in both cooling and heating mode. These values can increase due to ambient conditions during operation.

<sup>5</sup> Piping lengths are equivalent.

# GENERAL DATA / SPECIFICATIONS

Table 4: Vertical Air Handling Unit General Data, continued.

Type	Vertical Air Handling Unit				
System (Model) (Indoor Unit / Outdoor Unit)	LV181HV4 (LVN181HV4/ LUU189HV)	LV241HV4 (LVN241HV4/ LUU249HV)	LV361HV4 (LVN361HV4/ LUU369HV)	LV420HV (LVN420HV/ LUU428HV)	LV480HV (LVN480HV/ LUU488HV)
<i>Unit Data</i>					
Refrigerant Type <sup>3</sup>	R410A				
Additional Refrigerant Charge (oz./ft.)	0.43				
Refrigerant Control	EEV				
Indoor Unit Sound Pressure Level (dB(A)) (H/M/L) <sup>4</sup>	35 / 33 / 30	36 / 34 / 30	44 / 41 / 39	48 / 45 / 44	49 / 48 / 44
Outdoor Unit Sound Pressure Level (dB(A)) (Cool/Heat) <sup>4</sup>	48 / 52	48 / 52	52 / 54	52 / 54	52 / 54
Indoor Unit Net / Shipping Weight (lbs.)	123.5 / 135.1	123.5 / 135.1	129 / 140	165 / 188	165 / 188
Outdoor Unit Net / Shipping Weight (lbs.)	129 / 141	130.0 / 143.3	198.9 / 223.1	203 / 232	203 / 232
Power Wiring / Communications Cable (No. x AWG) <sup>2</sup>	4 x 14				
Power Supply (No. x AWG)	3 x 12	3 x 12	3 x 10	3 x 10	3 x 10
Compressor (Type x Qty.)	Twin Rotary x 1	Twin Rotary x 1	Scroll x 1	Twin Rotary x 1	Twin Rotary x 1
Dehumidification Rate (pts./hr.)	3.1	4.0	5.1	4.3	5.2
<i>Fan</i>					
Indoor Unit Type x Qty.	Sirocco				
Outdoor Unit Type x Qty.	Propeller x 1	Propeller x 1	Propeller x 2	Propeller x 2	Propeller x 2
Motor / Drive	ECM (Electronically Commutated Motor)			Brushless Digitally Controller / Direct	
<i>Airflow Rate</i>					
Indoor Unit (H / M / L [CFM])	640 / 580 / 480	710 / 640 / 480	990 / 880 / 800	1,260 / 1,100 / 1,000	1,400 / 1,260 / 1,000
Outdoor Unit (CFM)	2,048	2,048	1,942 x 2	1,942 x 2	1,942 x 2
Factory Set (High) External Static Pressure (in.wg)	Constant CFM @ 0.1" ~ 1.0" ESP			0.3	0.3
<i>Piping</i>					
Liquid (in.)	3/8				
Vapor (in.)	5/8				
Indoor Unit Condensate Drain O.D. / I.D. (in.)	Primary & Secondary: 3/4 FPT				
Minimum / Maximum Pipe Length (ft.) <sup>5</sup>	6.6 / 164	6.6 / 164	6.6 / 246	6.6 / 246	6.6 / 246
Piping Length (no additional refrigerant, ft.)	24.6				
Maximum Elevation Difference (ft.)	98.4				

EEV: Electronic Expansion Valve, IDU: Indoor Unit, ODU: Outdoor Unit. This unit comes with a dry helium charge.  
 This data is rated 0 ft above sea level, with 24.6 ft of refrigerant line per indoor unit and a 0 ft level difference between outdoor and indoor units.  
 Cooling capacity rating obtained with air entering the indoor coil at 80°F dry bulb (DB) and 67°F wet bulb (WB); and outdoor ambient conditions of 95°F dry bulb (DB) and 75°F wet bulb (WB).  
 Heating capacity rating obtained with air entering the indoor unit at 70°F dry bulb (DB) and 60°F wet bulb (WB); and outdoor ambient conditions of 47°F dry bulb (DB) and 43°F wet bulb (WB).  
 1 Power Input is rated at high speed. Cooling range can be extended from 5°F down to -4°F using the Low Ambient Wind Baffle Kit (sold separately)  
 2 All communication / connection (power) cable from the outdoor unit to the indoor unit

are field supplied and is to be a minimum four-conductor, 14 AWG, stranded, shielded or unshielded (if shielded, it must be grounded to the chassis of ODU only), and must comply with applicable local and national codes.  
 3 Take appropriate actions at the end of HVAC equipment life to recover, recycle, reclaim or destroy R410A refrigerant according to applicable regulations (40 CFR Part 82, Subpart F) under section 608 of CAA.  
 4 Sound pressure levels are tested in an anechoic chamber under ISO Standard 3745 and are the same in both cooling and heating mode. These values can increase due to ambient conditions during operation.  
 5 Piping lengths are equivalent.

# ELECTRICAL DATA

## Electrical Data

Table 5: Vertical Air Handling Unit ODU Electrical Data.

Nominal Tons	Model Name	Unit			Power Supply		Compressor Quantity	Compressor Motor RLA (Cooling)	Condenser Fan Motor(s)	
		Hz	Volts	Voltage Range	MCA	MOP			Condenser Fan Quantity.	Condenser Fan Motor FLA
1.5	LUU189HV	60	208/230	Min.: 187 Max.: 253	20	30	1	13.5	1	1.6
2.0	LUU249HV				20	30	1	13.5	1	1.6
3.0	LUU369HV				32	40	1	22.0	2	1.6 x 2
3.5	LUU428HV				32	40	1	21.0	2	1.6 x 2
4.0	LUU488HV				32	40	1	21.0	2	1.6 x 2

Voltage tolerance is  $\pm 10\%$ .

Maximum allowable voltage unbalance is 2%.

RLA = Rated Load Amps.

MCA = Minimum Circuit Ampacity.

Maximum Overcurrent Protection (MOP) is calculated as follows:  
 (Largest motor FLA x 2.25) + (Sum of other motor FLA) rounded down to the nearest standard fuse size.

# FUNCTIONS, CONTROLS, AND OPTIONS

Indoor Unit

## Functions, Controls, and Options for LVN181HV4, LVN241HV4, LVN361HV4, LVN420HV, LVN480HV

Table 6: Indoor Unit—Functions, Controls and Options.

Indoor Unit Type		Vertical Air Handling Unit
Airflow	Air Supply Outlet	1
	Airflow steps (fan/cool/heat)	3/3/3
	Washable anti-fungal filter <sup>1</sup>	X
Operation	Drain pump	X
	E.S.P Control	√
	Hot Start	√
	Self diagnostics	√
	Soft Dry (dehumidification)	√
	Auto changeover	√
	Auto restart	√
	Child lock	o
	Sleep mode	√
	Timer (on/off)	√
	Weekly schedule	√
	Two thermistor control	o
	Controllers	7-Day programmable controller
Simple wired remote controller		o
Wireless LCD remote control <sup>2</sup>		o
Dry contact		√
Dry contact (temperature setting)		X
Central control (LGAP)		√
Special Functions	Wi-Fi <sup>3</sup>	o
	Auxiliary Heater Relay Kit for NJ Frames (PRARH1)	o
	AHU Communications Kit (PAHCMR000)	o

<sup>1</sup>Primary washable filters.

<sup>2</sup>Requires wired zone controller.

<sup>3</sup>Requires Wi-Fi module PWFMD200.

√ = Standard feature

o = Unit option

X = Not Available

# FUNCTIONS, CONTROLS, AND OPTIONS

## Outdoor Unit

### Functions, Controls, and Options for LUU189HV, LUU249HV, LUU369HV, LUU428HV, LUU488HV

Table 7: Outdoor Unit—Functions, Controls and Options.

Outdoor Unit						
Category	Functions	LUU189HV	LUU249HV	LUU369HV	LUU428HV	LUU488HV
Reliability	Defrost / Deicing	O	O	O	O	O
	High pressure sensor	O	O	O	O	O
	Phase protection	X	X	X	X	X
	Restart delay (3-minutes)	O	O	O	O	O
	Self diagnosis	O	O	O	O	O
	Soft start	O	O	O	O	O
Convenience	Night Quiet Operation	O	O	O	O	O
	Mode Lock	O	O	O	O	O
	Pump Down (Forced Cooling Operation)	O	O	O	O	O
	Network solution (LGAP)	O	O	O	O	O
Central Controller	AC Smart 5	PACS5A000	PACS5A000	PACS5A000	PACS5A000	PACS5A000
	ACP 5	PACP5A000	PACP5A000	PACP5A000	PACP5A000	PACP5A000
	PI485	PMNFP14A1	PMNFP14A1	PMNFP14A1	PMNFP14A1	PMNFP14A1
Remote Controller	MultiSITE CRC1	PREMTBVC0	PREMTBVC0	PREMTBVC0	PREMTBVC0	PREMTBVC0
	MultiSITE CRC1+	PREMTBVC1	PREMTBVC1	PREMTBVC1	PREMTBVC1	PREMTBVC1
Integration Solution	MultiSITE Communications Manager	PBACNBTR0A	PBACNBTR0A	PBACNBTR0A	PBACNBTR0A	PBACNBTR0A

√ = Standard feature

O = Unit option

X = Not Available



# OUTDOOR UNIT DIMENSIONS

## LUU189HV, LUU249HV

### Dimensions for LUU189HV, LUU249HV

Figure 4: LUU189HV, LUU249HV Unit Dimensions.

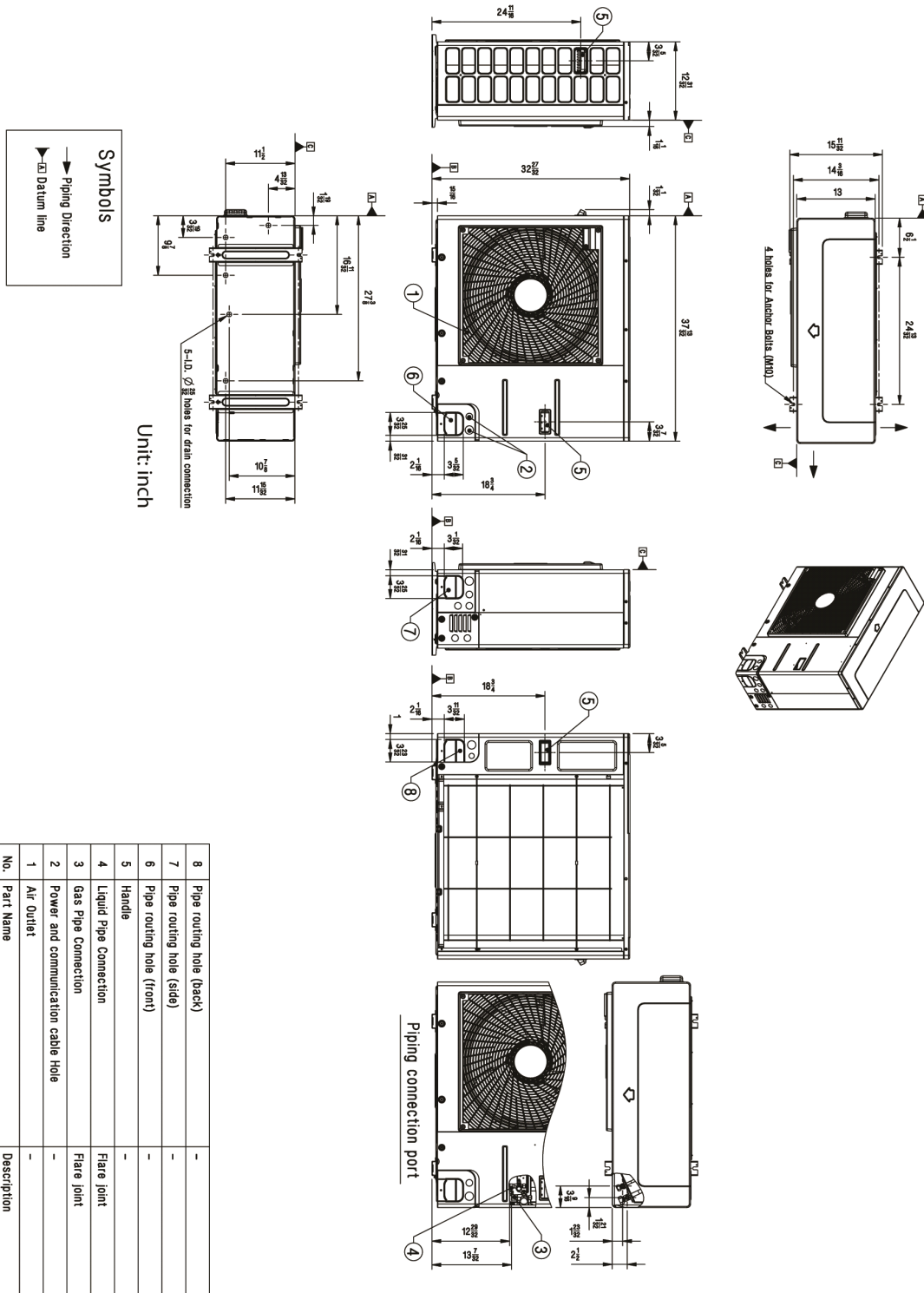

# OUTDOOR UNIT DIMENSIONS

LUU369HV, LUU428HV, LUU488HV

## Dimensions for LUU369HV, LUU428HV, LUU488HV

Figure 5: LUU369HV, LUU428HV, LUU488HV Unit Dimensions.

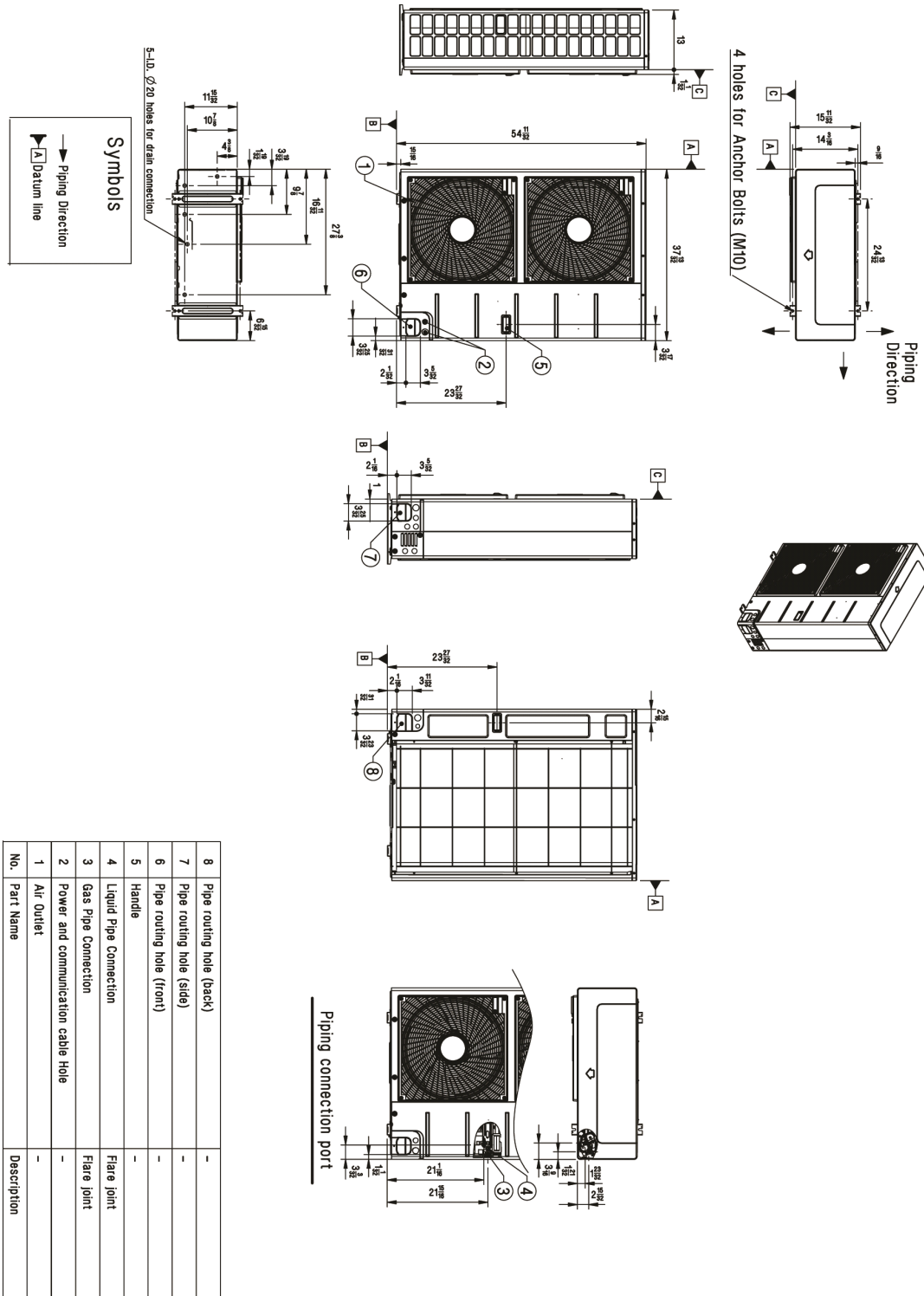

# INDOOR UNIT DIMENSIONS

LVN181HV4, LVN241HV4, LVN361HV4

## Dimensions for LVN181HV4, LVN241HV4, LVN361HV4 (NJ Chassis)

Figure 6: LVN181HV4, LVN241HV4, LVN361HV4 Indoor Unit Dimensions.

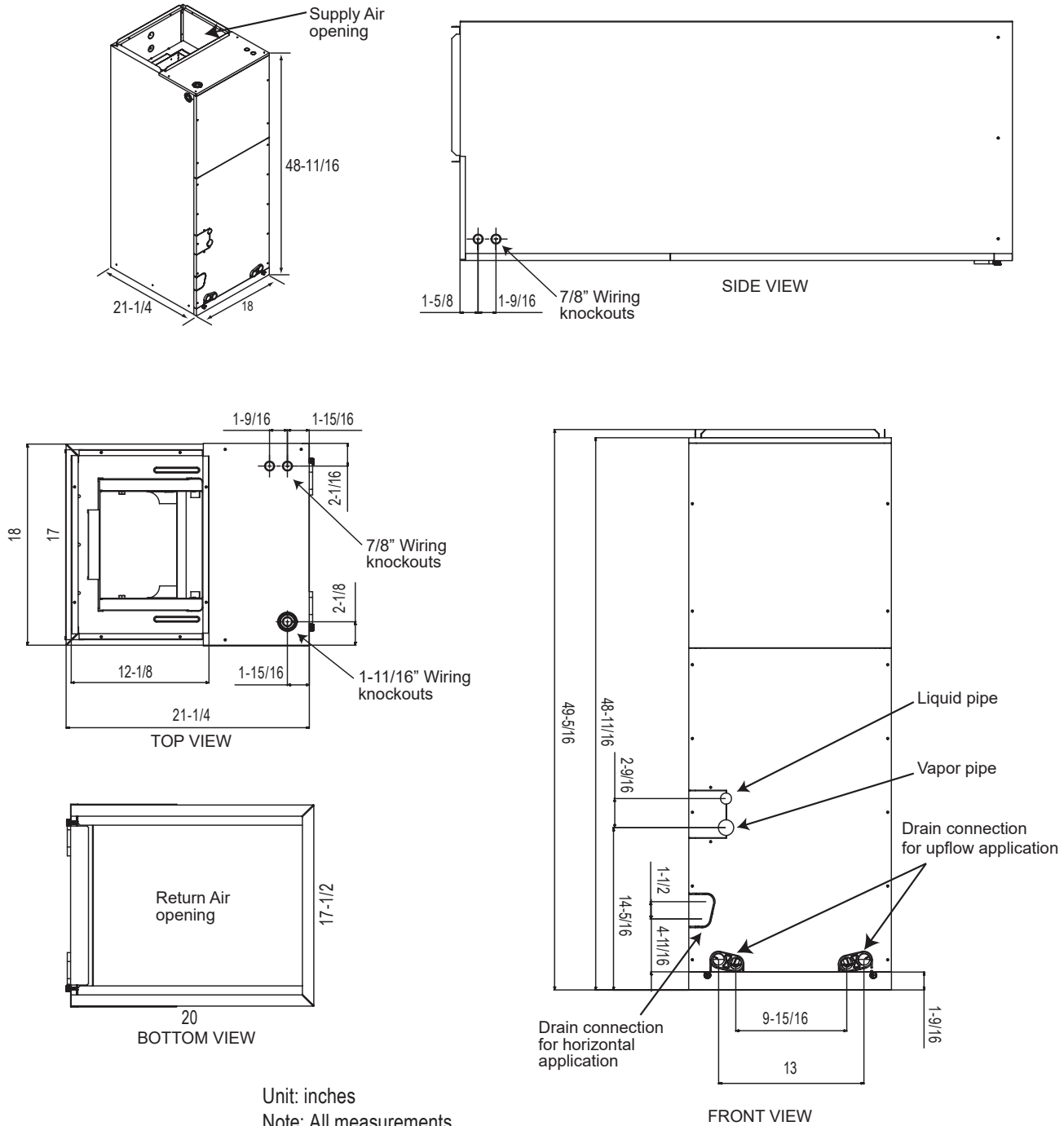

Unit: inches  
 Note: All measurements have a tolerance of  $\pm 1/4$  in.

# INDOOR UNIT DIMENSIONS

LVN420HV, LVN480HV

## Dimensions for LVN420HV, LVN480HV (NK Chassis)

Figure 7: LVN420HV, LVN480HV Indoor Unit Dimensions.

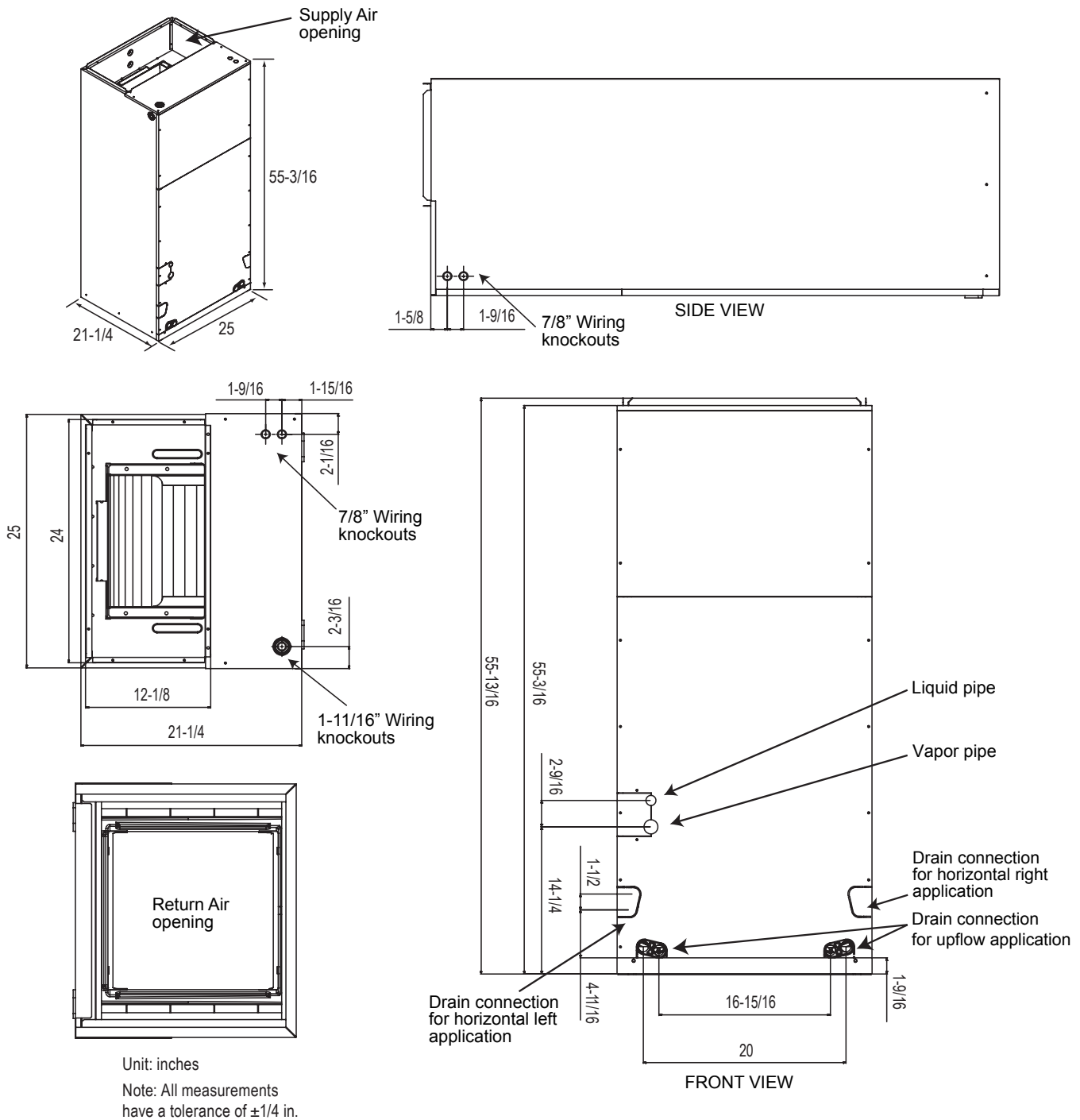

### Indoor Unit Sound Pressure Measurement

Figure 8: Sound Pressure Measurement Location.

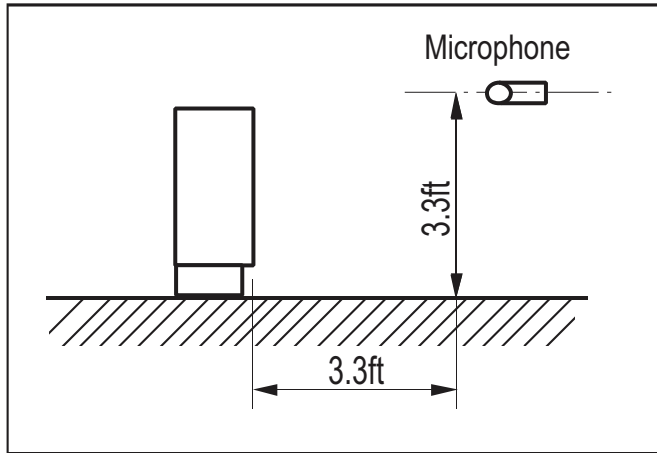

- Measurements are taken 3.3 ft away from the front of the unit.
- Sound pressure levels are measured in dB(A) with a tolerance of  $\pm 1$ .
- Sound pressure levels are tested in an anechoic chamber under ISO Standard 3745.

Operating Conditions:

- Power source: 220V/60 Hz
- Sound level will vary depending on a range of factors including the construction (acoustic absorption coefficient) of a particular room in which the unit was installed.

### Indoor Unit Sound Pressure Levels

Table 8: Vertical Air Handling Unit Indoor Unit Sound Pressure Levels.

Model	Sound Pressure Levels dB(A)		
	High Fan Speed	Medium Fan Speed	Low Fan Speed
LVN181HV4	35	33	30
LVN241HV4	36	34	30
LVN361HV4	44	41	39
LVN420HV	48	45	44
LVN480HV	49	48	44

# ACOUSTIC DATA

## Indoor Units Sound Pressure

### Sound Pressure Diagrams for LVN181HV4, LVN241HV4, LVN361HV4

Figure 9: LVN181HV4 Sound Pressure Level Diagram.

LVN181HV4

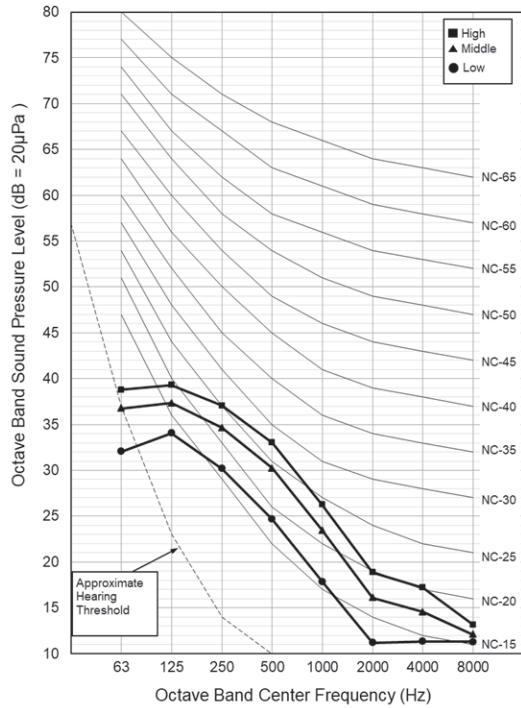

Figure 10: LVN241HV4 Sound Pressure Level Diagram.

LVN241HV4

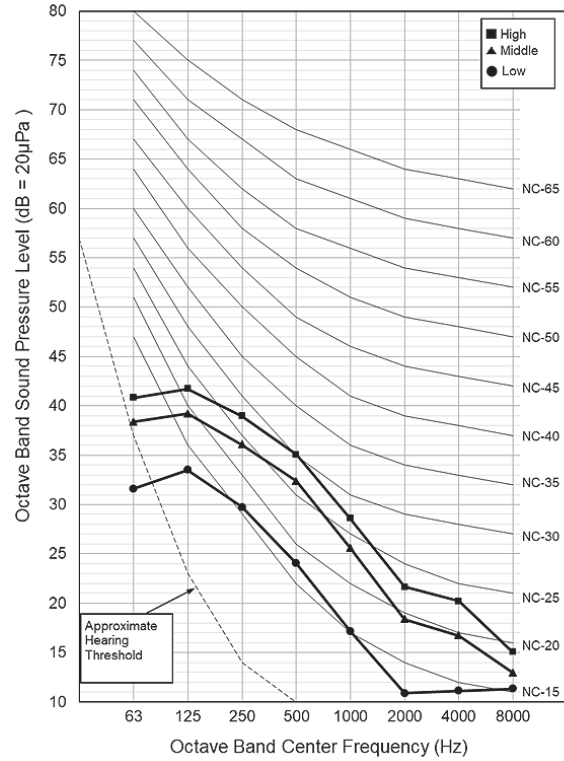
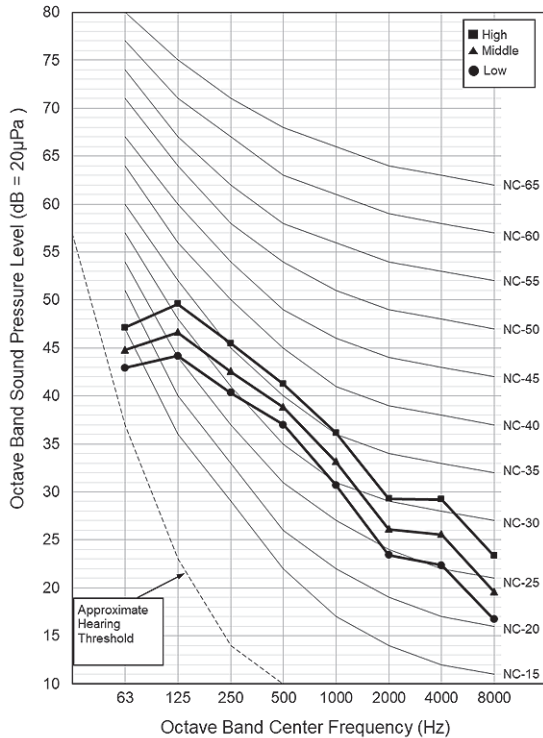

Figure 11: LVN361HV4 Sound Pressure Level Diagram.

LVN361HV4



# ACOUSTIC DATA

## Indoor Units Sound Pressure

### Sound Pressure Diagrams for LVN420HV, LVN480HV

Figure 12: LVN420HV Sound Pressure Level Diagram.

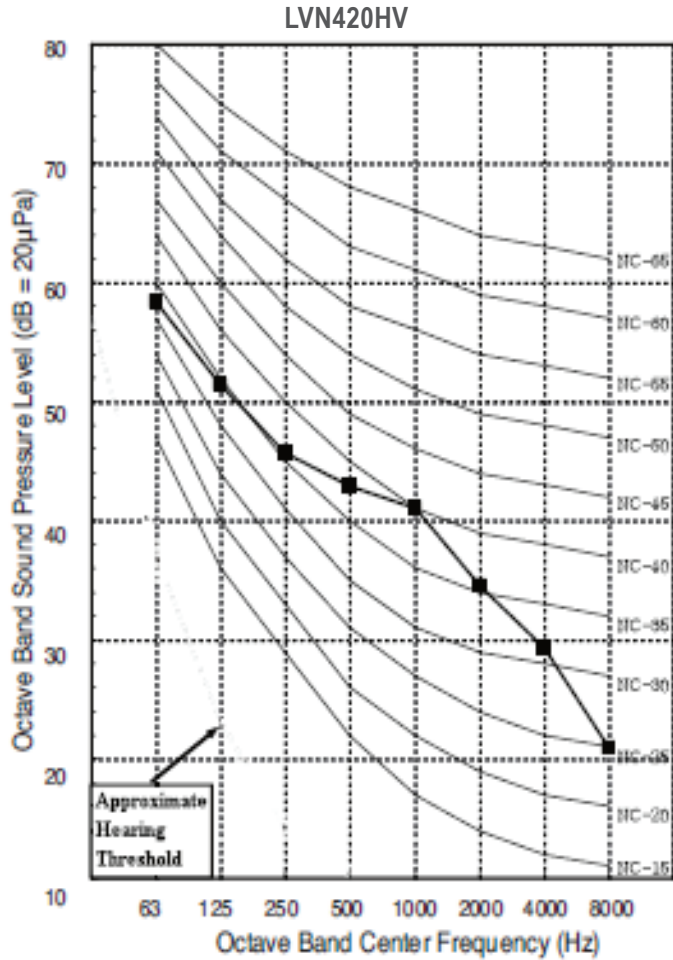
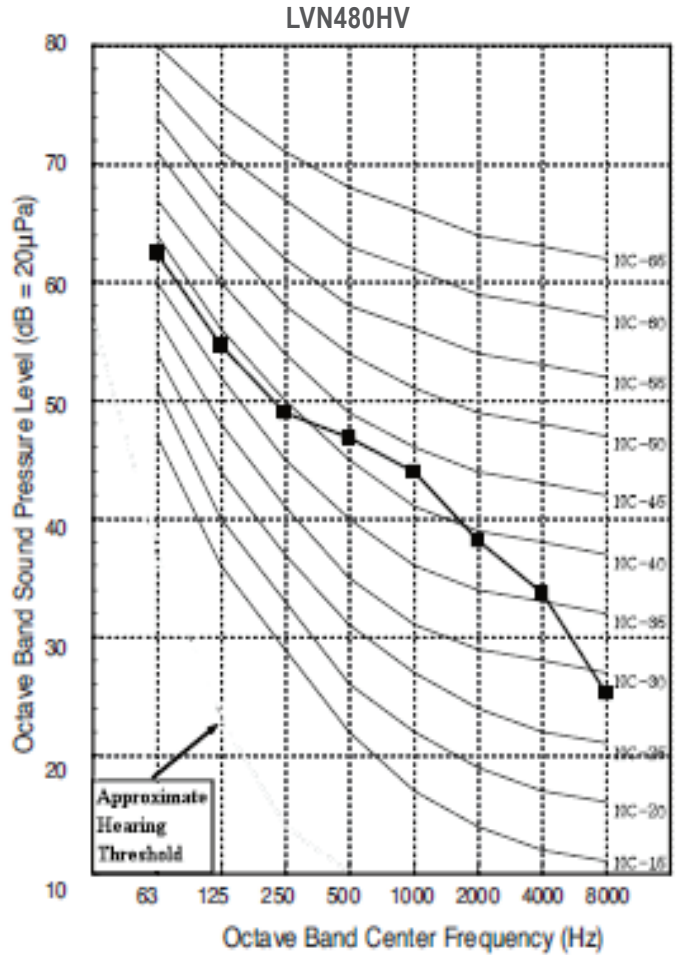

Figure 13: LVN480HV Sound Pressure Level Diagram.



Product Data

# ACOUSTIC DATA

## Indoor Units Sound Power

### Sound Power Levels

Table 9: Vertical Air Handling Unit Sound Power Levels.

Indoor Unit Model	Sound Power Levels dB(A)
	High Fan Speed
LVN181HV4	54
LVN241HV4	55
LVN361HV4	63
LVN420HV	61
LVN480HV	62

- Data is valid under diffuse field conditions.
- Data is valid under nominal operating conditions.
- Sound power level is measured using rated conditions, and tested in a reverberation room per ISO 3741 standards.
- Sound level will vary depending on a range of factors such as construction (acoustic absorption coefficient) of particular area in which the equipment is installed.
- Reference acoustic intensity: 0dB = 10E-6μW/m<sup>2</sup>

### Sound Power Level Diagrams for LVN181HV4, LVN241HV4

Figure 14: LVN181HV4 Sound Power Level Diagram.

Figure 15: LVN241HV4 Sound Power Level Diagram.

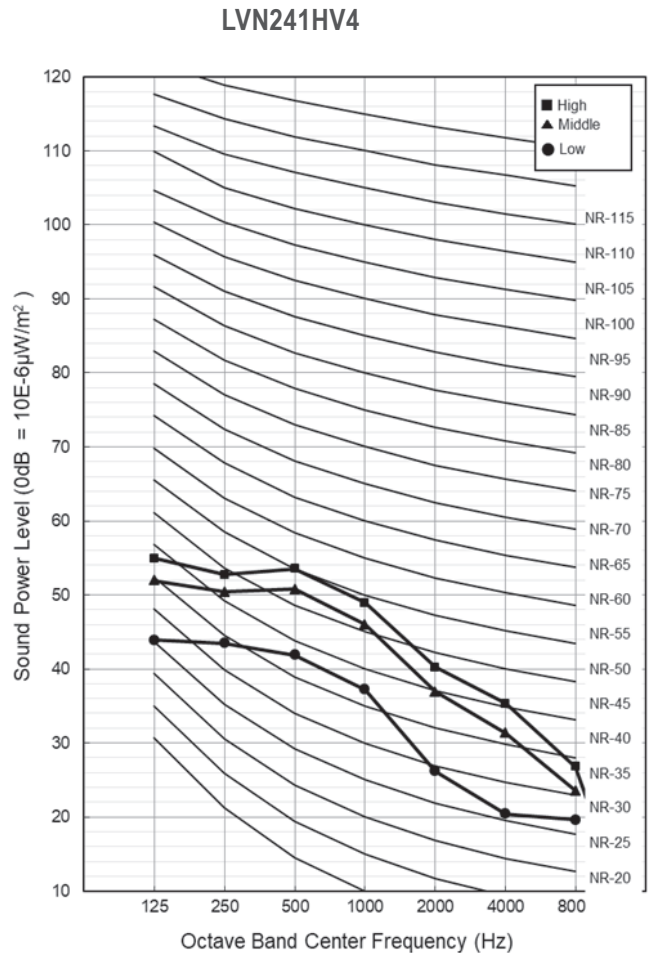
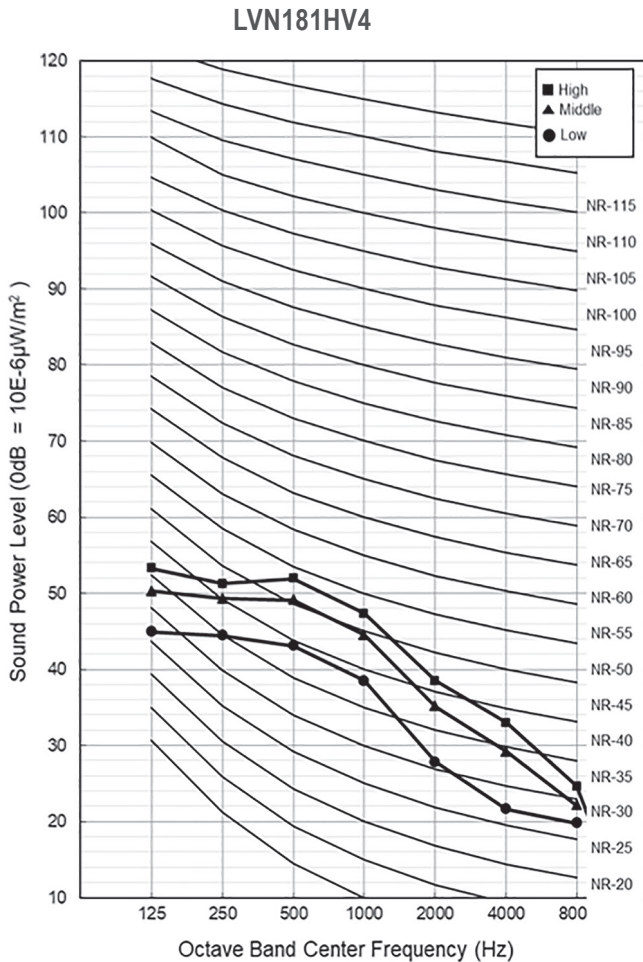



### Sound Power Level Diagram for LVN361HV4

Figure 16: LVN361HV4 Sound Power Level Diagram.  
LVN361HV4

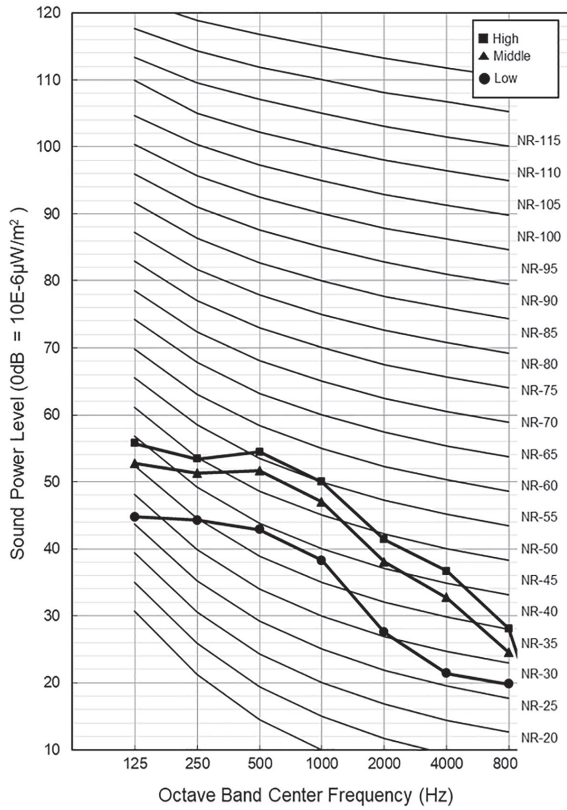

# ACOUSTIC DATA

## Indoor Units Sound Power

### Sound Power Level Diagrams for LVN420HV, LVN480HV

Figure 17: LVN420HV Sound Power Level Diagram.

LVN420HV  
Noise Criteria (NR)

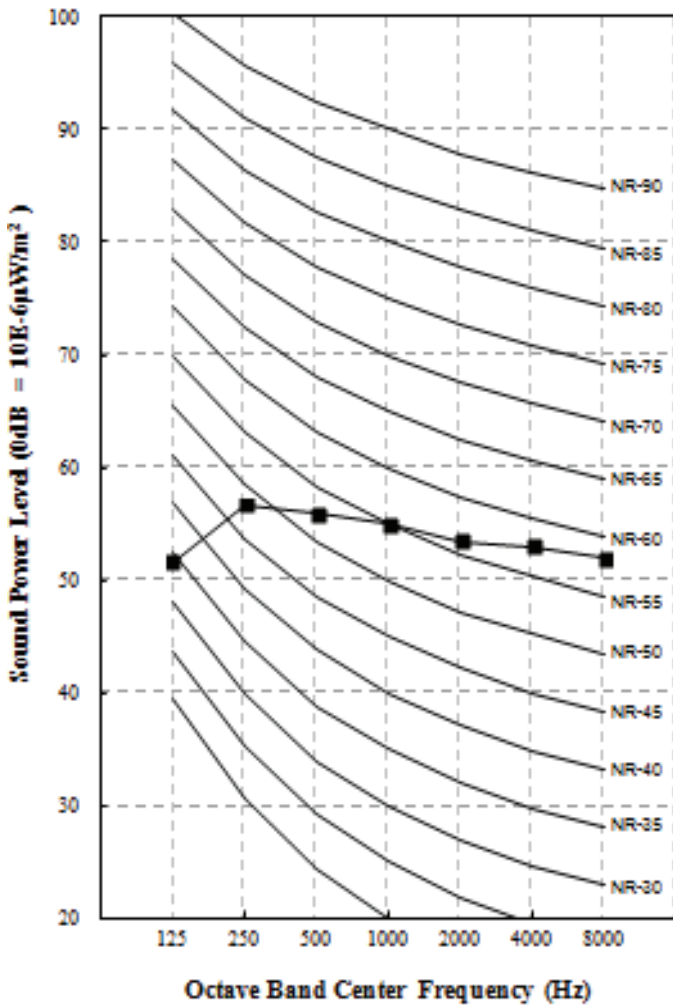
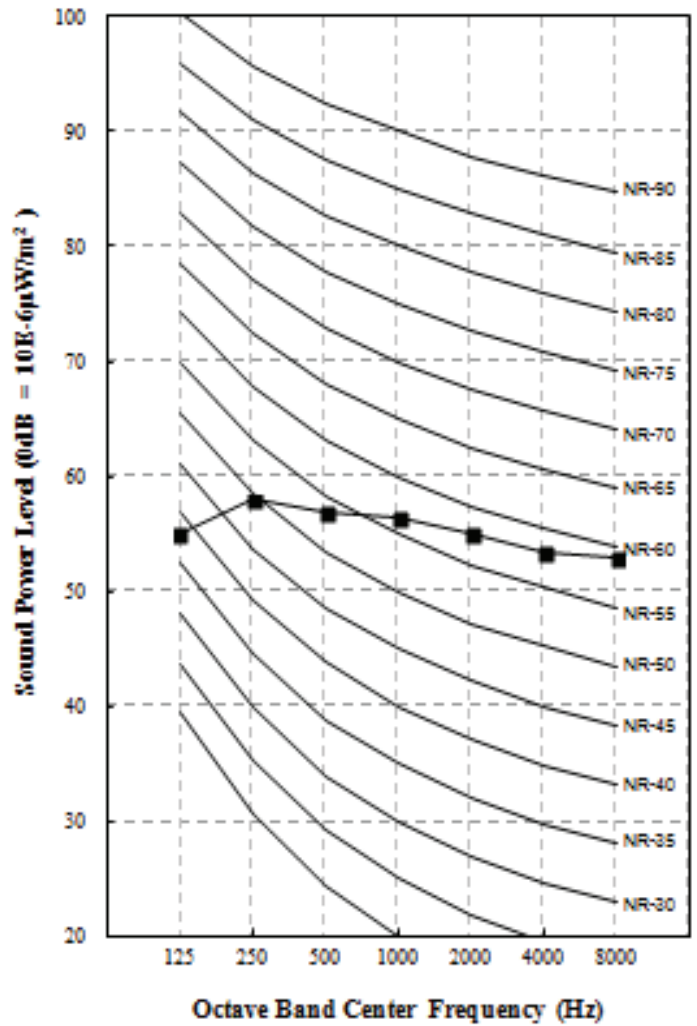

Figure 18: LVN480HV Sound Power Level Diagram.

LVN480HV  
Noise Criteria (NR)



# ACOUSTIC DATA

## Outdoor Units Sound Pressure

### Outdoor Unit Sound Pressure Level Measurement

Figure 19: Vertical Air Handling Unit Outdoor Unit Sound Pressure Level Measurement Location.

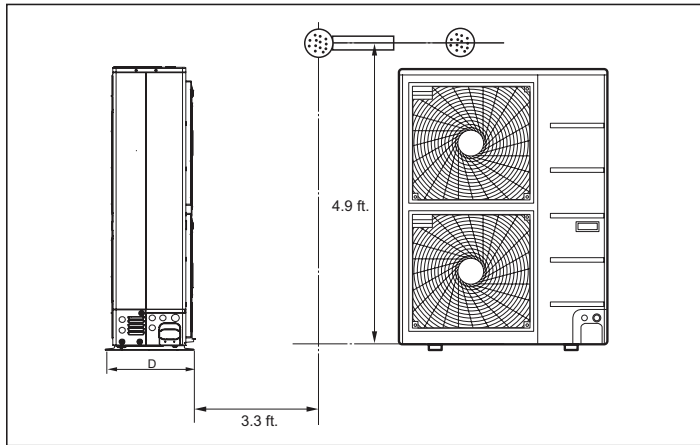

- Measurements taken with no attenuation and units operating at full load normal operating condition.
- Sound level will vary depending on a range of factors such as construction (acoustic absorption coefficient) of particular area in which the equipment is installed.
- Sound power levels are measured in dB(A)±1.
- Tested in anechoic chamber per ISO Standard 3745.

### Outdoor Unit Sound Pressure Levels

Table 10: Vertical Air Handling Unit Outdoor Unit Sound Pressure Levels (dB[A]).

Outdoor Unit Model	Sound Pressure Level [dB(A)]	
	Cooling	Heating
LUU189HV	48	52
LUU249HV	48	52
LUU369HV	52	54
LUU428HV	52	54
LUU488HV	52	54

# ACOUSTIC DATA

## Outdoor Units Sound Pressure

### Sound Pressure Diagrams for LUU189HV, LUU249HV, LUU369HV, LUU428HV, LUU488HV

Figure 20: LUU189HV, LUU249HV Sound Pressure Level Diagram.

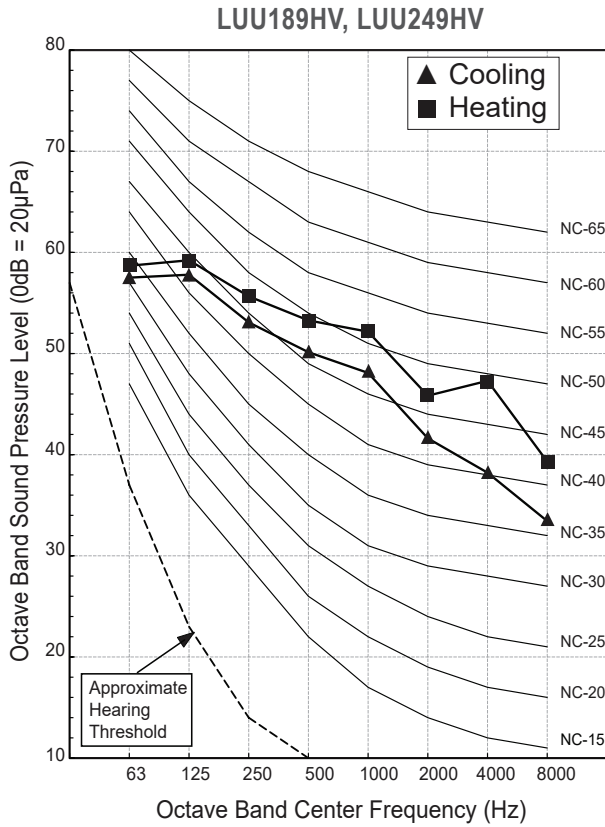

Figure 21: LUU369HV Sound Pressure Level Diagram.

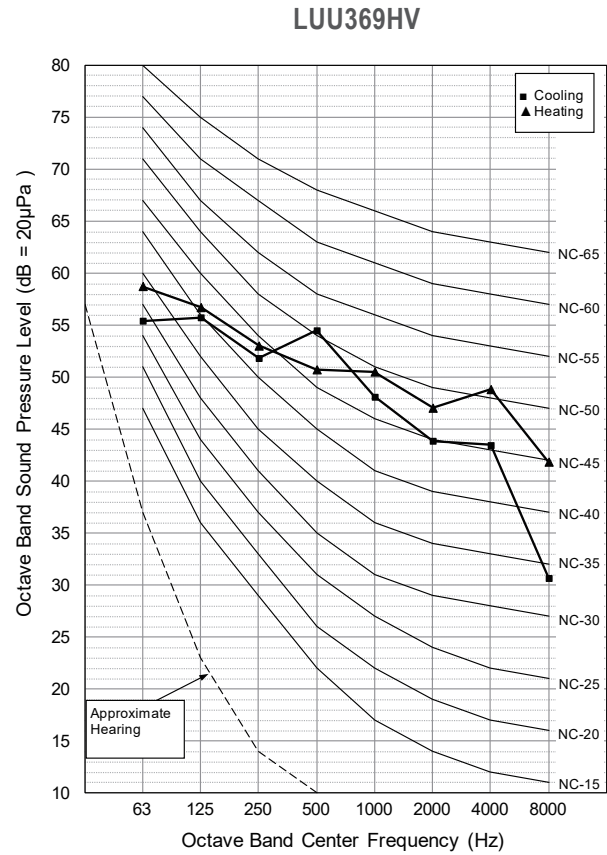
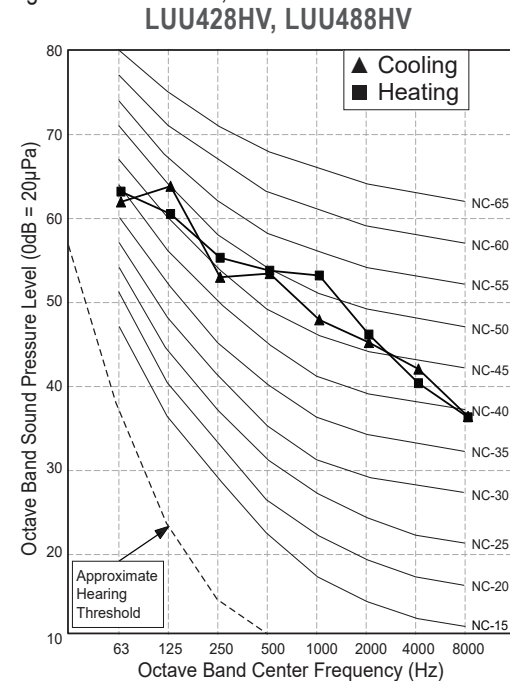

Figure 22: LUU428HV, LUU488HV Sound Pressure Level Diagram.



# ACOUSTIC DATA

## Outdoor Units Sound Power

### Outdoor Unit Sound Power Levels

Table 11: Vertical Air Handling Unit ODU Sound Power Levels.

Outdoor Unit Model	Sound Power Levels dB(A)
	Max
LUU189HV	67
LUU249HV	67
LUU369HV	65
LUU428HV	67
LUU488HV	68

### Sound Power Level Diagram for LUU189HV, LUU249HV

Figure 23: LUU189HV, LUU249HV Sound Power Level Diagram.

LUU189HV, LUU249HV

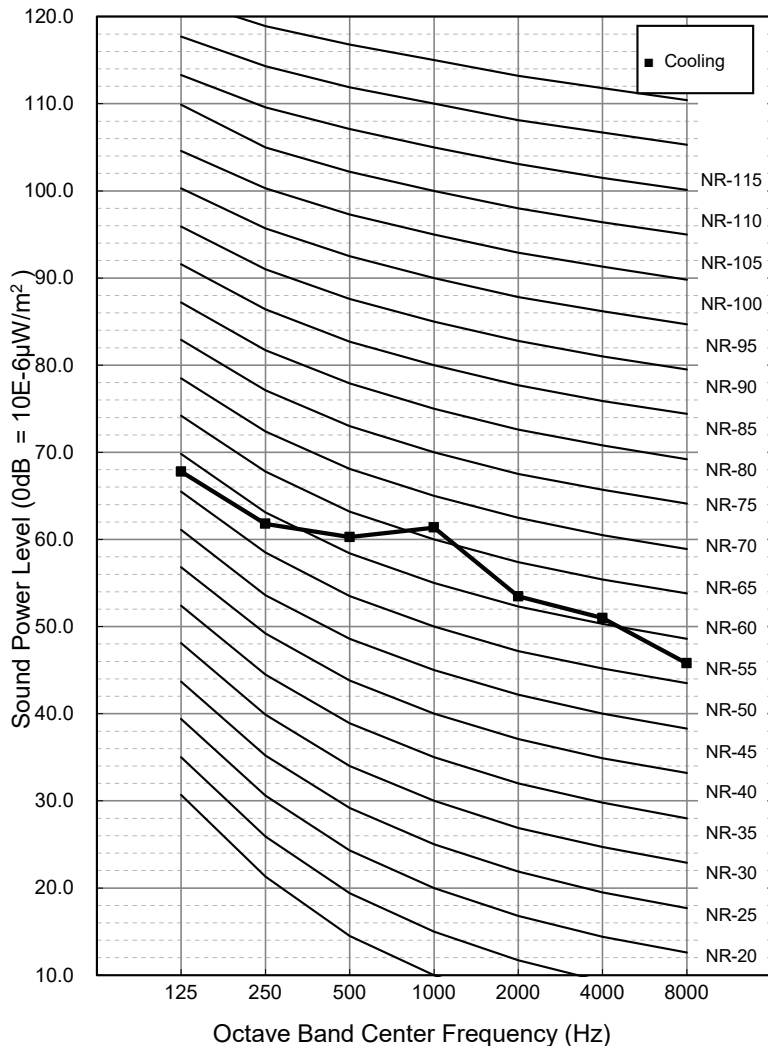

Product Data

# ACOUSTIC DATA

## Outdoor Units Sound Power

### Sound Power Level Diagram for LUU369HV

Figure 24: LUU369HV Sound Power Level Diagram.

LUU369HV

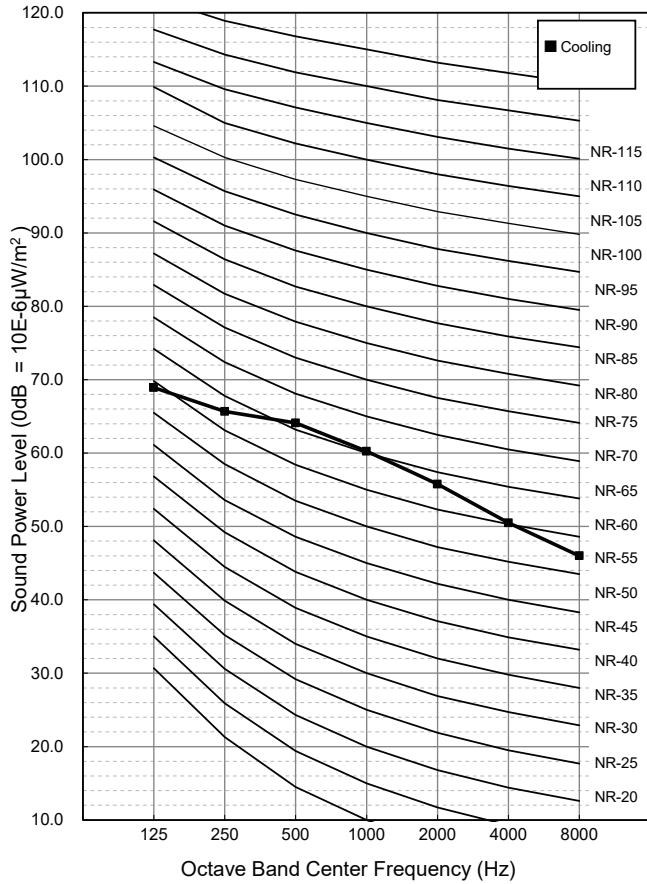

### Sound Power Level Diagrams for LUU428HV, LUU488HV

Figure 25: LUU428HV, LUU488HV Sound Power Level Diagram.

LUU428HV, LUU488HV

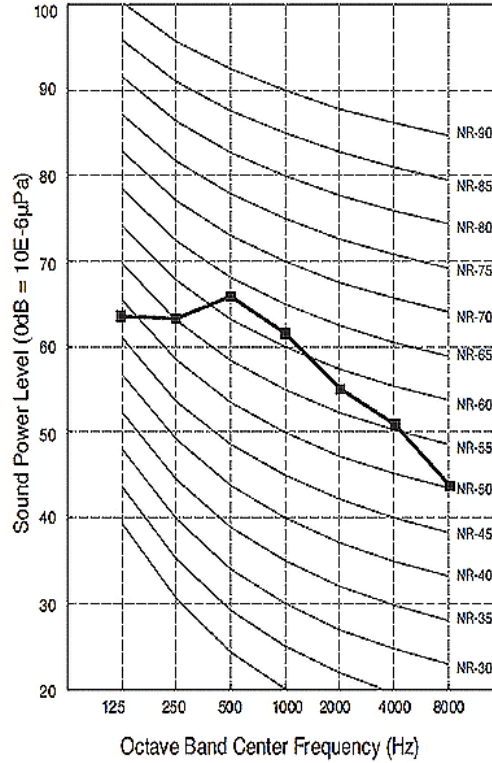
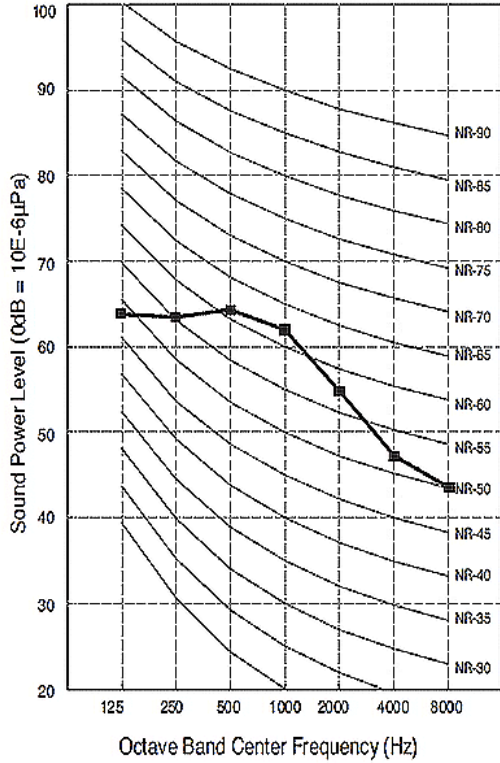

# REFRIGERANT FLOW DIAGRAM

## Indoor Units

### Refrigerant Flow Diagram for LVN181HV4, LVN241HV4, LVN361HV4, LVN420HV, LVN480HV

Figure 26: Indoor Unit Refrigerant Flow Diagrams.

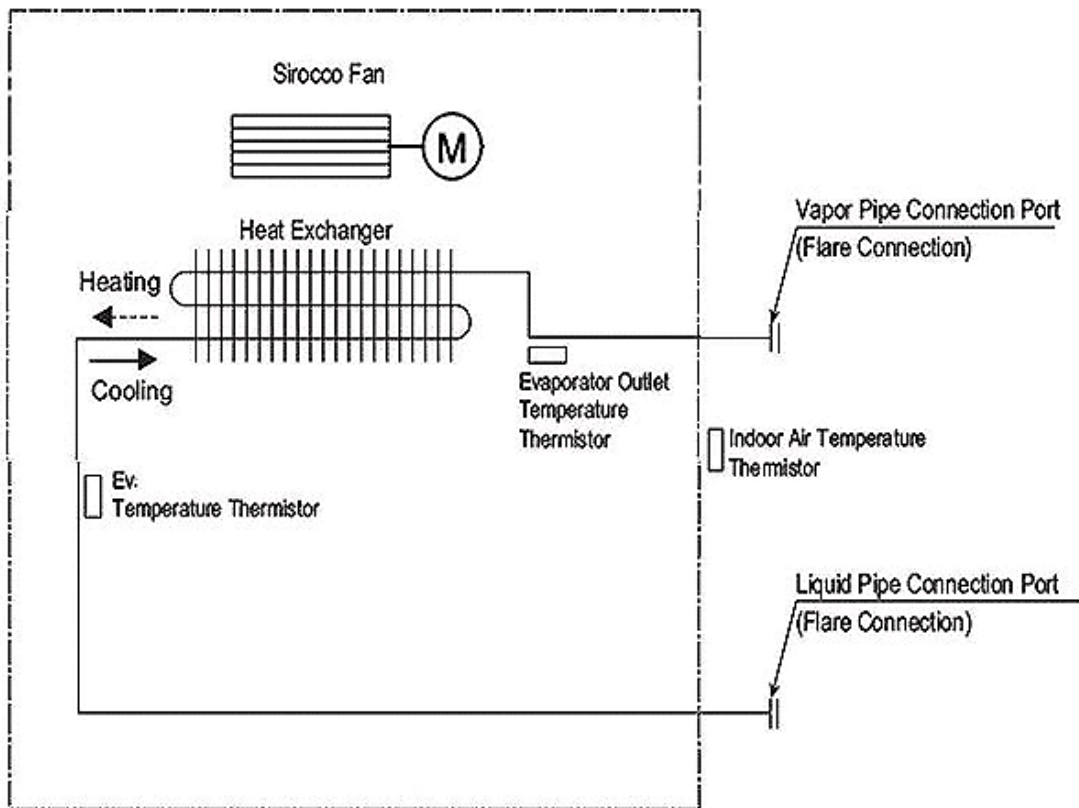

Table 12: NJ, NK Frame Refrigerant Pipe Connection Port Diameters.

Indoor Unit Model	Liquid (inch)	Vapor (inch)
<i>NJ Frames</i>		
LVN181HV4	3/8	5/8
LVN241HV4		
LVN361HV4		
<i>NK Frames</i>		
LVN420HV	3/8	5/8
LVN480HV		



# REFRIGERANT FLOW DIAGRAM

## Outdoor Units

### Refrigerant Flow Diagram for LUU189HV, LUU249HV, LUU369HV, LUU428HV, LUU488HV

Figure 27: LUU189HV, LUU249HV, LUU369HV, LUU428HV, LUU488HV Refrigerant Flow Diagrams.

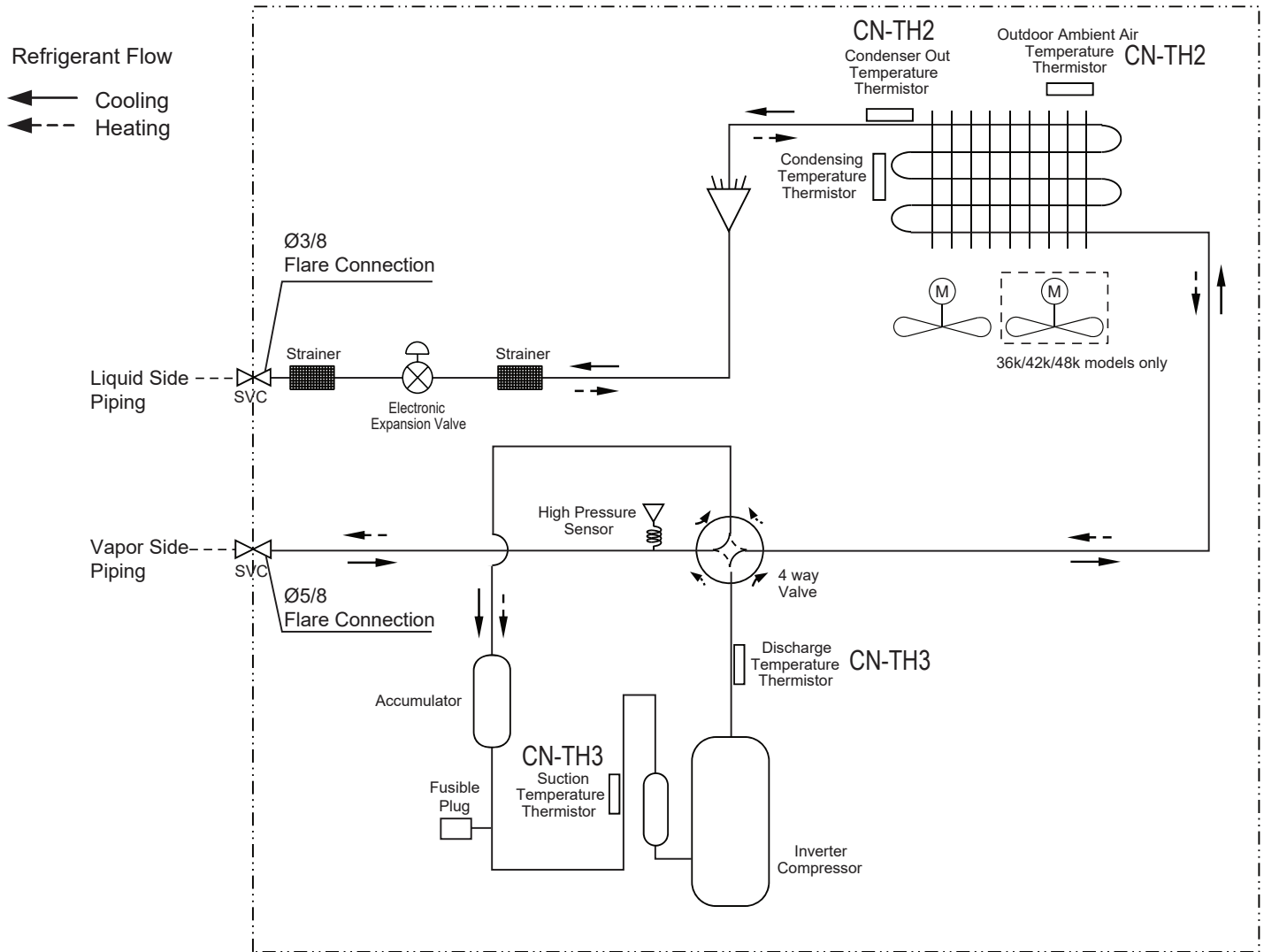

Product Data

Table 13: Vertical Air Handling Unit ODU LUU189~488HV Thermistor Details.

Description (Based on Cooling Mode)	PCB Connector	
Suction Temperature Thermistor	CN-TH3	CN-TH3
Discharge Temperature Thermistor		
Condenser Outlet Temperature Thermistor	CN-TH2	CN-TH2
Outdoor Ambient Air Temperature Thermistor		
Condenser Inlet Temperature Thermistor		

# INDOOR UNIT WIRING DIAGRAM

## Wiring Diagram for LVN181HV4, LVN241HV4, LVN361HV4

Figure 28: Indoor Unit Wiring Diagram.

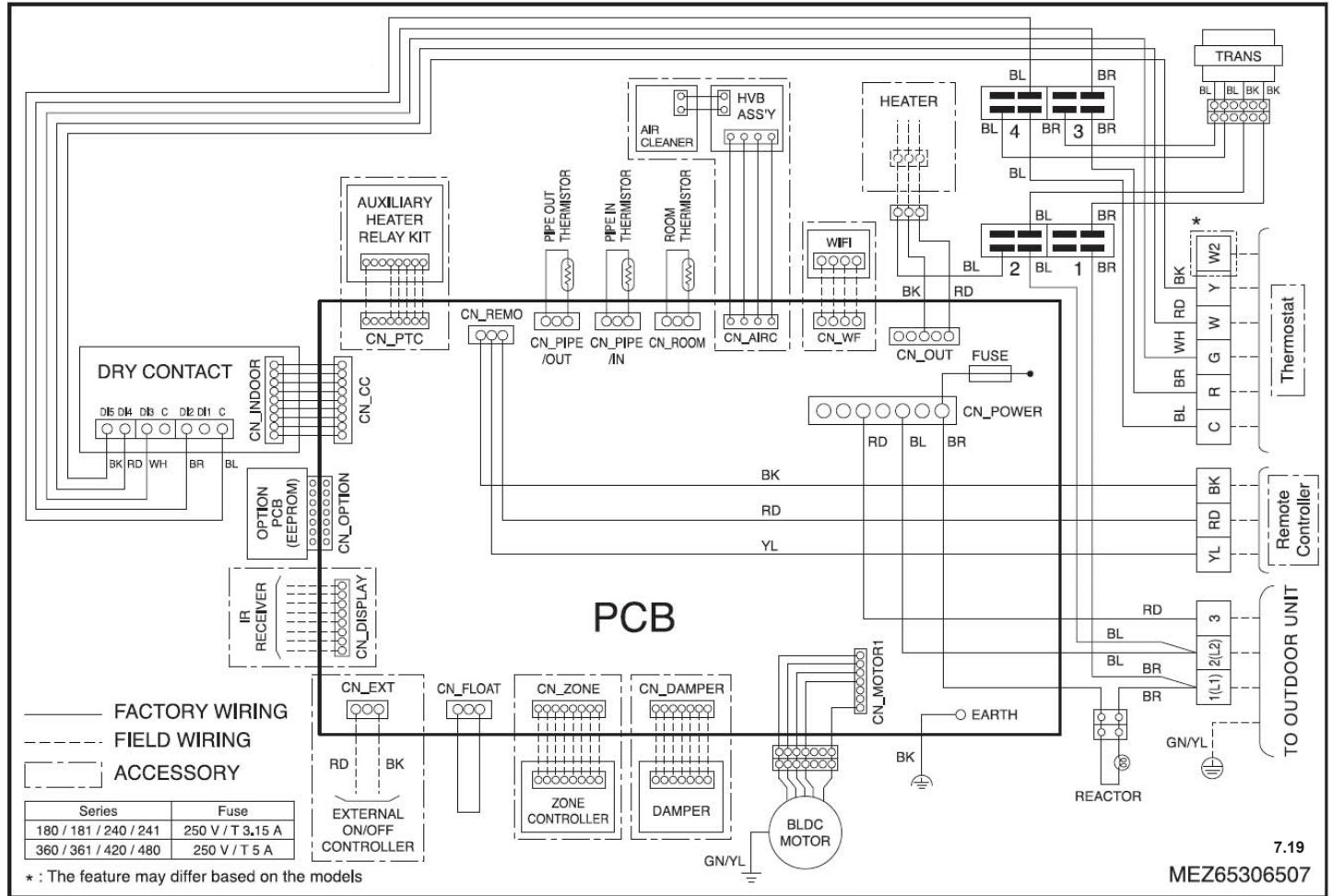

7.19  
MEZ65306507

# INDOOR UNIT WIRING DIAGRAM

## Wiring Diagram for LVN420HV, LVN480HV

Figure 29: Indoor Unit Wiring Diagram.

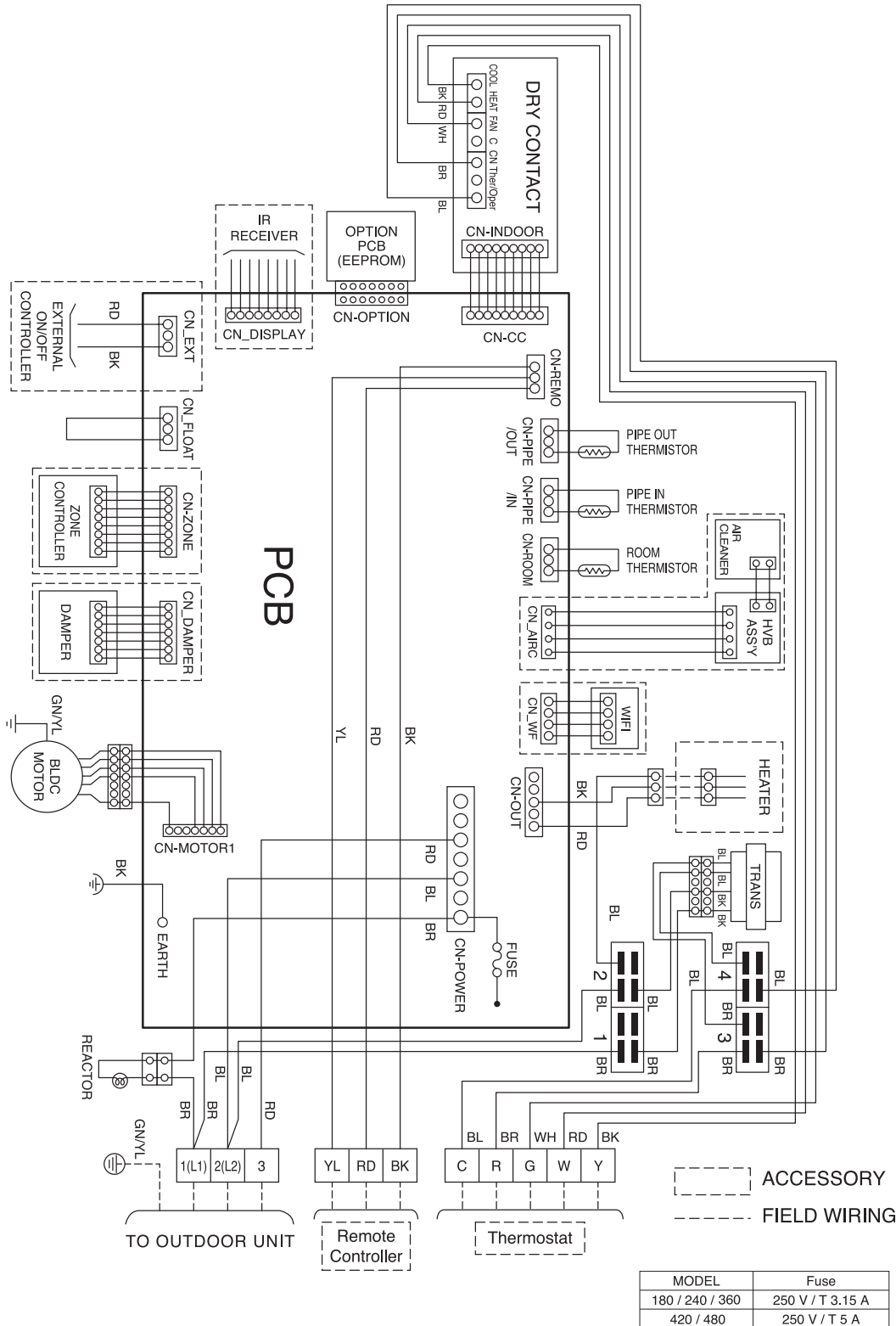

Product Data

# OUTDOOR UNIT WIRING DIAGRAM

## Wiring Diagram for LUU189HV

Figure 30: Outdoor Unit Wiring Diagram.

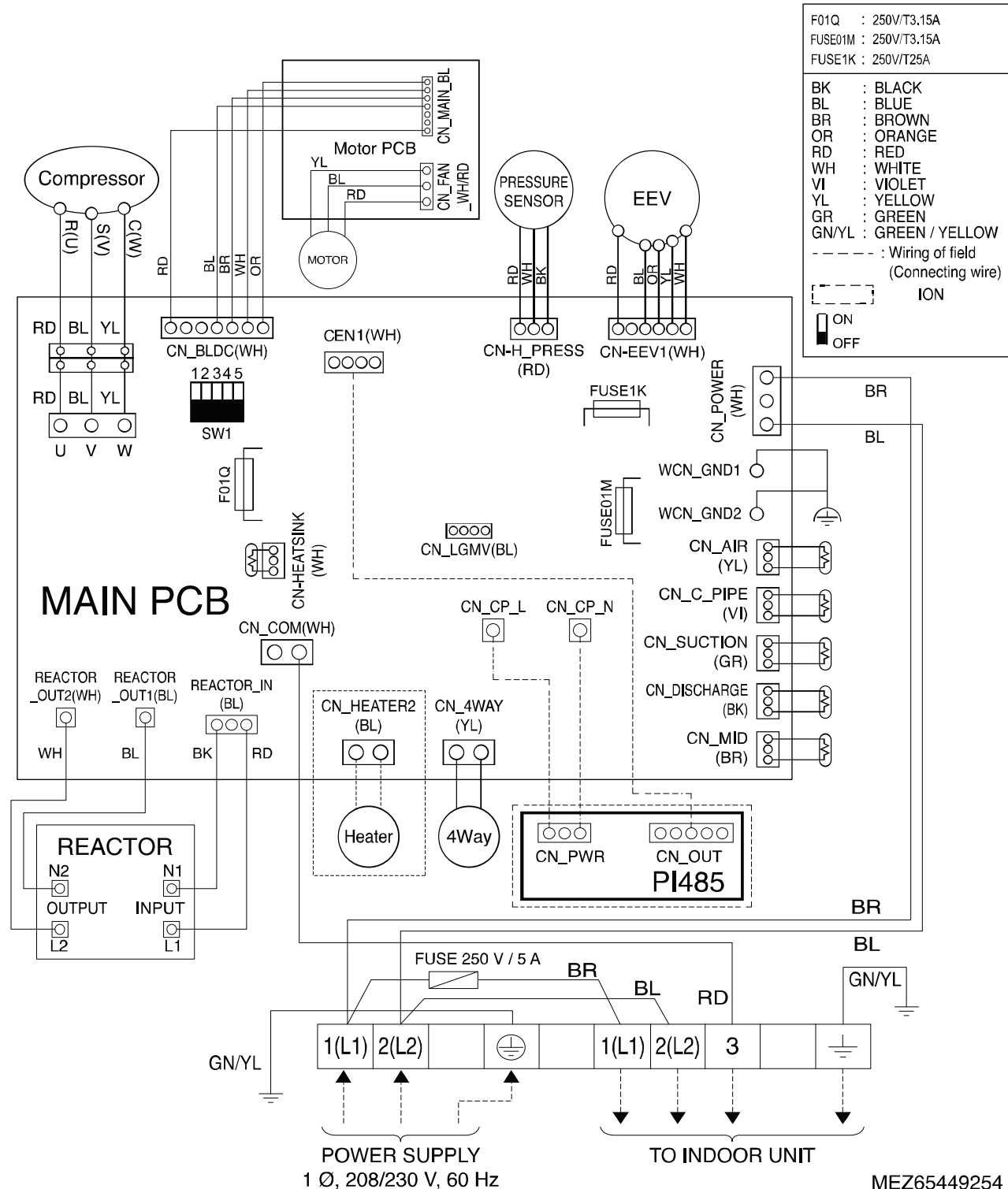

MEZ65449254  
7.19

# OUTDOOR UNIT WIRING DIAGRAM

## Wiring Diagram for LUU249HV

Figure 31: Outdoor Unit Wiring Diagram.

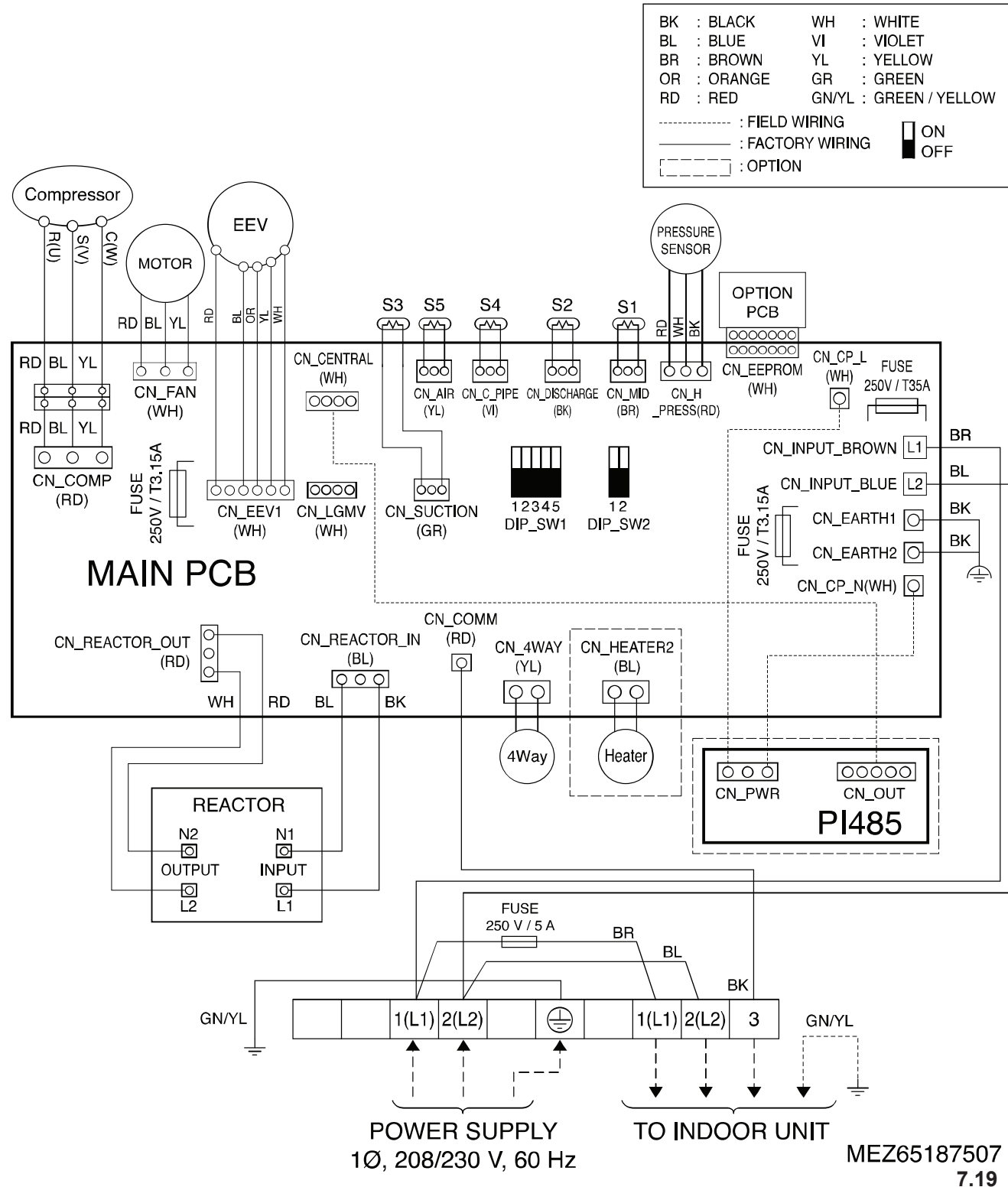

# OUTDOOR UNIT WIRING DIAGRAM

## Wiring Diagram for LUU369HV

Figure 32: Outdoor Unit Wiring Diagram.

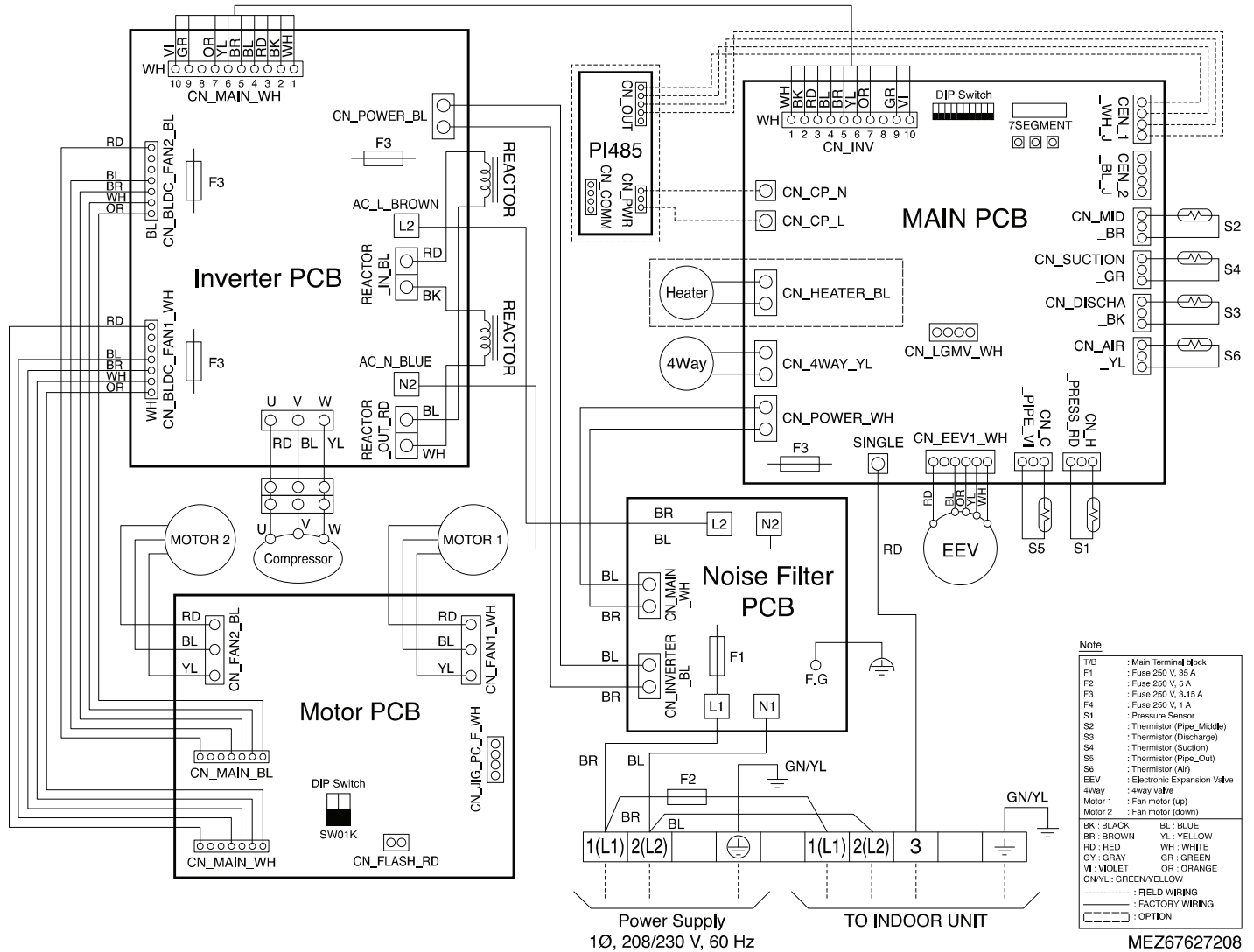

MEZ67627208  
7.19

# OUTDOOR UNIT WIRING DIAGRAM

## Wiring Diagram for LUU428HV, LUU488HV

Figure 33: Outdoor Unit Wiring Diagram.

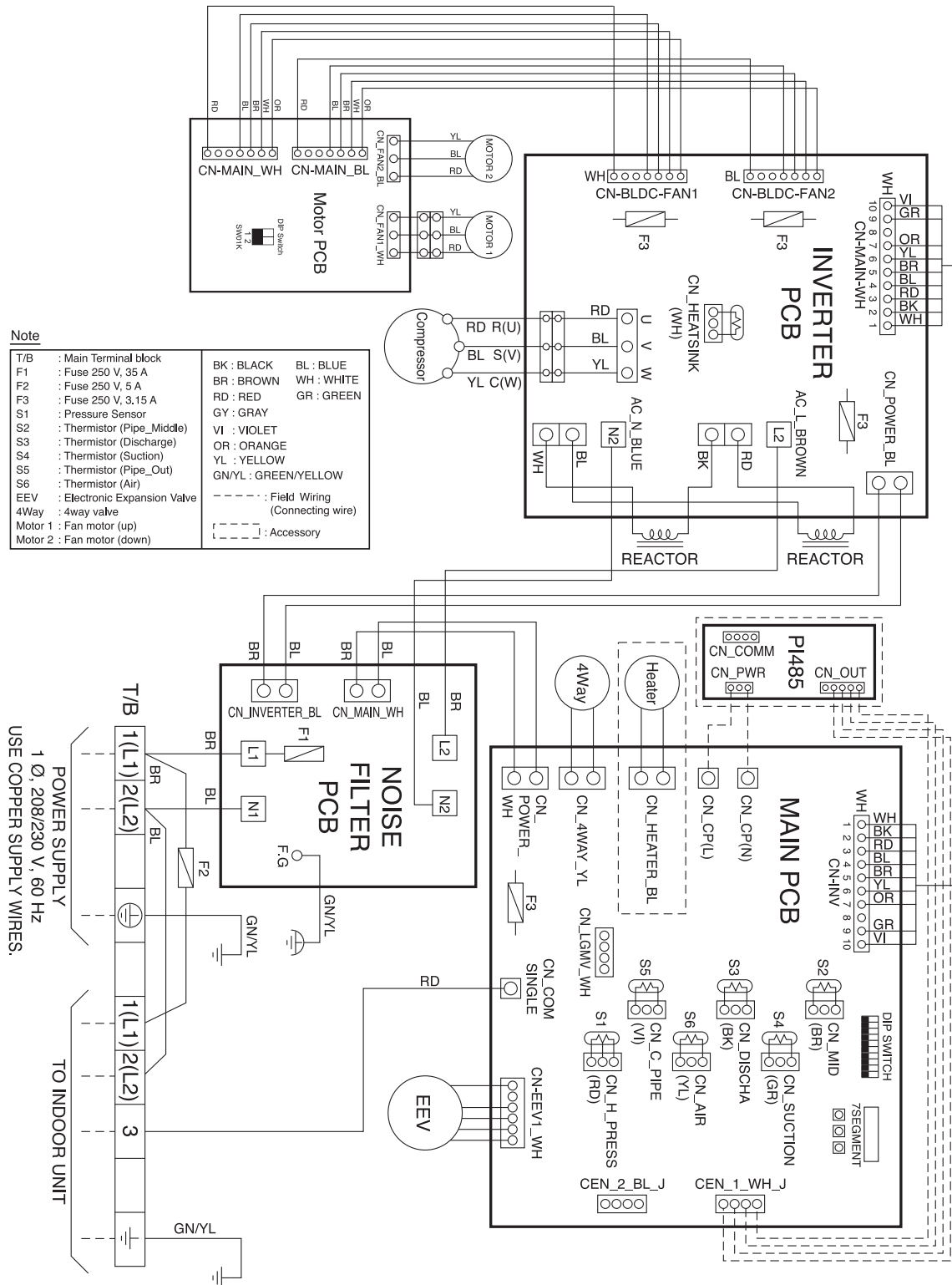

Product Data

# ELECTRICAL WIRING

## NJ/NK Frame Wiring Diagram Legend

Table 14: NJ/NK Frame Wiring Diagram Legend.

Terminal	Purpose	Function
CN-POWER	AC Power supply	AC Power line
CN-MOTOR1	Fan motor output	Motor output of BLDC
CN_OUT	Heater	Connection for heater
CN-D/PUMP	Drain pump output	AC output for drain pump
CN-FLOAT	Float switch input	Float switch sensing
CN-ZONE	Zone controller	Zone controller connection
CN-OPTION	Optional PCB EPROM	Option PCB connection
CN-EXT	External ON / OFF controller	External ON / OFF controller connection
CN-DISPLAY	Display	Display of indoor status
CN-CC	Dry contact	Dry Contact connection
CN-PIPE/OUT (RD)	Discharge pipe sensor	Pipe out thermistor
CN-LEAK (VI)	Refrigerant leak detector	Refrigerant leak detector connection
CN-PIPE/IN (WH)	Suction pipe sensor	Pipe in thermistor
CN-REMO (GN)	Wired remote controller	Wired remote control connection
CN-ROOM (YL)	Room sensor	Room air thermistor
CN-DAMPER	Damper Controller	Damper connection
CN-AIRC	Air Cleaner	Air Cleaner connection
CN-WF	Wifi	Wifi Module connection
CN-PTC	Auxiliary Heater Relay Kit	Auxiliary Heater Relay Kit Second stage heat



# ELECTRICAL WIRING

## Dip Switch Settings

### Dip Switch Settings for Indoor Unit PCB

Table 15: NJ/NK Frame DIP Switch Settings.

Dip Switch	Function	Off	On	Description
SW1	COMMUNICATION	Off (default)	–	–
SW2	CYCLE	Off (default)	–	–
SW3	GROUP CONTROL	Master	Slave	Group control setting using 7-Day Programmable Controller; selects Master/Slave on each indoor unit.
SW4	DRY CONTACT MODE	Variable	Auto	Sets operation mode for optional Dry Contact accessory. 1. Variable: Auto or Manual Mode can be set through 7-Day Programmable Controller or Wireless Remote Controller (factory default setting is Auto if there is no setting). 2. Auto: For Dry Contact, it is always Auto mode.
SW5	CONTINUOUS FAN	Off	On	Selects continuous fan for ducted indoor units. 1. On: Indoor unit fan will always operate at a set fan speed, except when the system is off, or the outdoor unit is in defrost mode (when the outdoor unit is in defrost mode, the fan will operate at super low fan speed). 2. Off: Indoor unit fan speed can be changed by on / off.
SW6	HEATER INTERLOCK	Off	On	Selects heater interlock function for Vertical Air Handling units. 1. On: Automatic (heater will automatically operate during heating mode). 2. Off: Manual (heater needs to be manually turned on during heating mode).
SW7				Off
SW8				Off

### Note:

To operate the indoor unit without Internal Electric Heater, Dip switch 1, 2, 6, 8 must be set OFF.

To operate the indoor unit with Internal Electric heater, Dip switch 6 must be set ON.

- SW6 ON: Automatic Heater operation: Heater operates automatically.
- SW6 OFF: Manual Heater operation: Owner's involvement is required for on/off operation.

If you operate the indoor unit with Internal Electric heater with Dip switch 5, note the following:

- SW5 ON: Fan operates continuously. During defrosting or oil return operation, uninterrupted heating can be attained, as a result of continuous heater and fan operation.
- SW5 OFF: Fan discontinuous operation. There would be reduction in heating capacity while defrosting or oil return operation.

# ELECTRICAL CONNECTIONS

## General Power Wiring / Communications Cable Guidelines

- Follow manufacturer's circuit diagrams displayed on the inside of the control box cover.
- Have a separate power supply for the indoor units.
- Provide a circuit breaker switch between the power source and the indoor unit.
- Confirm power source specifications.
- Properly ground the outdoor unit and the indoor unit per NEC and local codes.
- Connect the wiring firmly so that the wires cannot be easily pulled out.
- Confirm that the electrical capacity is sufficient.
- Power supply to the outdoor unit must be selected based on NEC and local codes. Maximum allowable voltage fluctuation  $\pm 10\%$  or name-plate rated value.
- It is recommended that a circuit breaker is installed, especially if conditions could become wet or moist.
- Include a disconnect in the power wiring system. Add an air gap contact separation of at least 1/8 inch in each active (phase) conductor.
- Any openings where the field wiring enters the cabinet must be completely sealed.

⊘ Do not install power wiring to the outdoor unit and the communication / connection (power) cable to the indoor unit in the same conduit. Use separate conduits.

## Power Wiring / Communications Cable Specifications

- Power wiring to the outdoor unit must be solid or stranded, and must comply with the applicable local and national electric codes.
- Communication cable from the outdoor unit to the indoor unit must be a minimum of 14 AWG, four (4) conductor, shielded or unshielded (if shielded, must be grounded to chassis at ODU only) and must comply with applicable local and national codes.
- Communication cable from indoor unit to remote controller(s) is to be 22 AWG, 3-conductor, twisted, stranded, unshielded. Wiring must comply with all applicable local and national codes.

### **WARNING**

- *Terminal screws may become loose during transport. Properly tighten the terminal connections during installation or risk electric shock, physical injury, or death.*
- *Loose wiring may cause unit to malfunction, overheat, and catch fire, resulting in severe injury or death.*

### **Note:**

- *Terminal screws may loosen during transport. Properly tighten the terminal connections during installation or risk equipment malfunction or property damage.*
- *Loose wiring may cause unit malfunction, the wires to burnout or the terminal to overheat and catch fire. There is a risk of equipment malfunction or property damage.*

*A voltage drop may cause the following problems:*

- *Magnetic switch vibration, fuse breaks, or disturbance to the normal function of an overload protection device.*
- *Compressor will not receive the proper starting current.*

# ELECTRICAL CONNECTIONS

Figure 34: LV181HV4 and LV241HV4 General Power/Communications System Schematic.

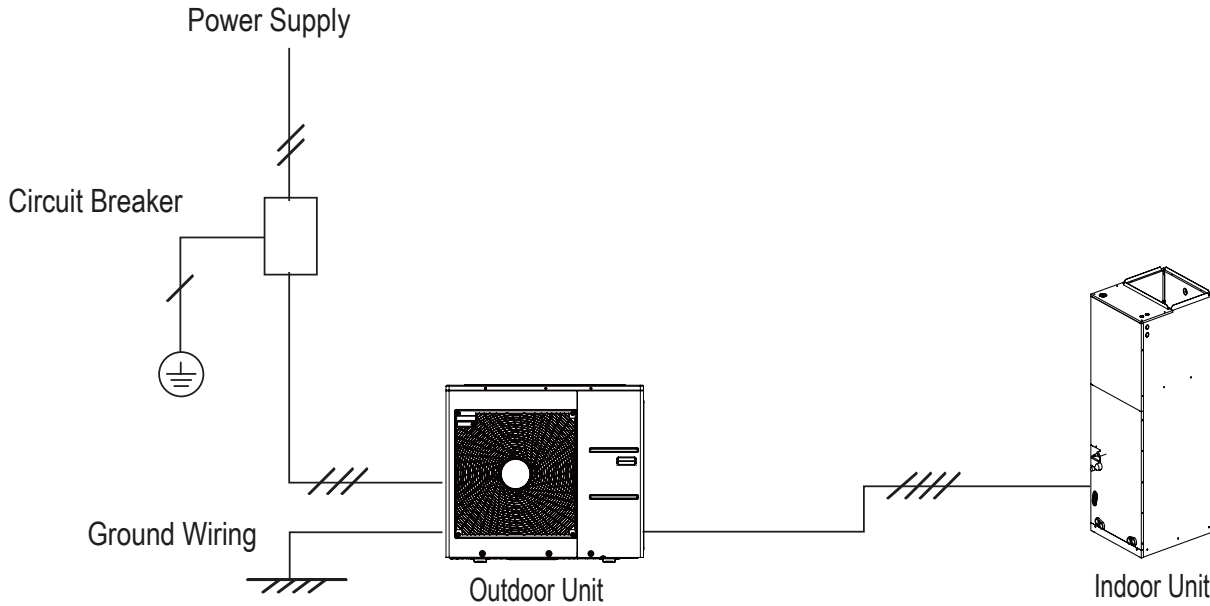
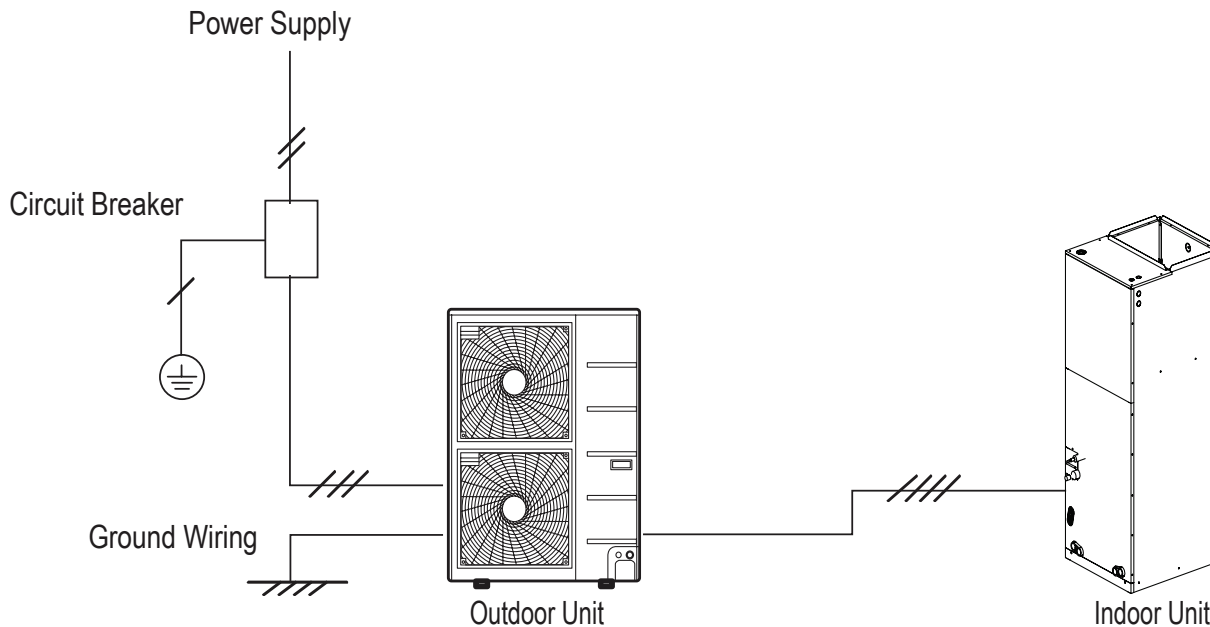

Figure 35: LV361HV4, LV480HV, and LV488HV General Power/Communications System Schematic.



## Note:

- Secure the separate wires in the control box panel using zip ties.
- Secure wiring with accessory clamps so that it does not touch the piping.
- Use a conduit for the communications cable / power wiring from the outdoor unit to the indoor units.
- Make sure the communications cable / power wiring from the outdoor units to the indoor units, and the power wiring to the outdoor unit are separate, otherwise, the outdoor unit operation may be affected by electrical noise and will malfunction or fail.

# ELECTRICAL CONNECTIONS

## Connecting the Power Wiring and Communications Cable

1. To access the terminal block, first unscrew the top front panel, and then unscrew the cover from the control box.
2. Knockout the access holes for the wiring. Insert the power wiring/communications cable from the outdoor unit through the conduits, pass the conduits through the designated access holes, and then insert the conduits into the control box. To prevent electromagnetic interference and product malfunction, leave a space between the power wiring and communications cable outside of the indoor unit.
3. Connect the power wiring and communications cables to the appropriate terminals on the indoor unit control board. Verify that the color and terminal numbers from the outdoor unit wiring match the color and terminal numbers on the indoor unit.
4. Fill in any gaps around the conduit access holes with sealant to prevent foreign particles from entering the indoor unit.

Figure 36: Connecting the Power Wiring and Communications Cable.

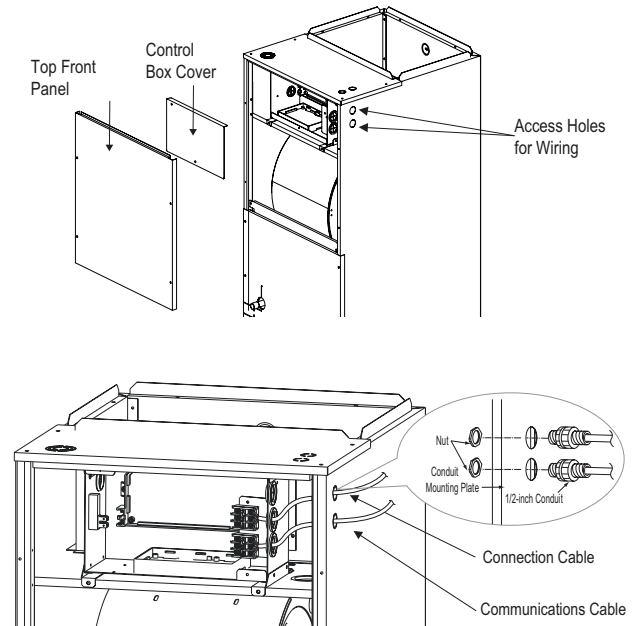
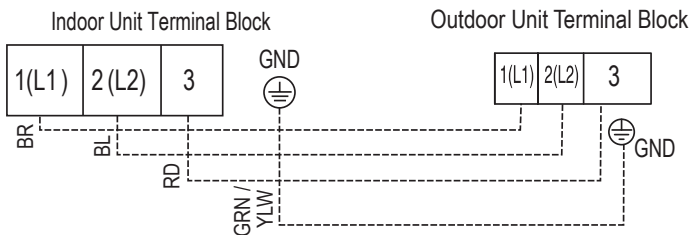

Figure 37: Indoor Unit to Outdoor Unit Power Wiring / Communications Cable Connections.



# ELECTRICAL CONNECTIONS

## Controller Options

Optional LG-supplied wired controller or wireless handheld controllers are available to be used with the Vertical Air Handling indoor units.

### Wireless Handheld Remote Controller features

- Operation Display Panel: Displays operation conditions.
- Temperature Control Button: Sets desired temperature.
- Fan Speed Button: Sets desired fan speed.
- On / Off Button: Turns system operation on and off.
- Mode Selection Check Button: Selects the operation mode: Cooling, Heating, Auto, Dry (Dehumidification), or Fan.

### Note:

Each function will display on the LED for about three (3) seconds when the power is first cycled on.

### Wired Controller Connections

Controllers can connect to the indoor unit in one of two different ways.

1. LG Wired Remote Extension Cable with Molex plug (PZCWRC1; sold separately) that connects to the CN-REMO terminal on the indoor unit PCB.
2. Field-supplied controller cable that connects to the indoor unit terminal block (must be at least UL2547 or UL1007, and at least FT-6 rated if local electric and building codes require plenum cable usage). Communication cable from indoor unit to remote controller(s) is to be 22 AWG, 3-conductor, twisted, stranded, unshielded. Wiring must comply with all applicable local and national codes.

Figure 38: PZCWRC1 LG Wired Remote Extension Cable.

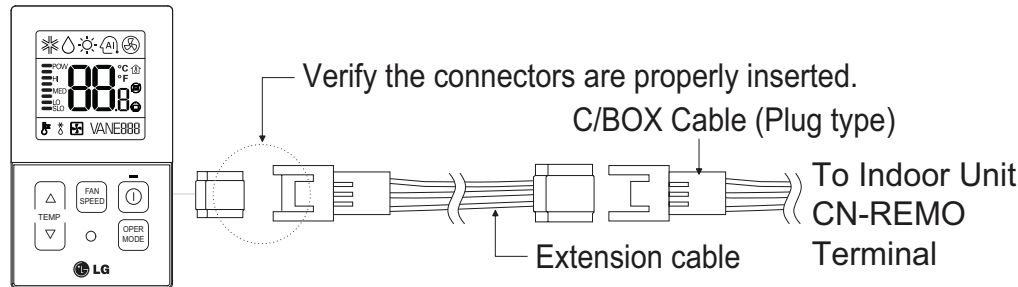
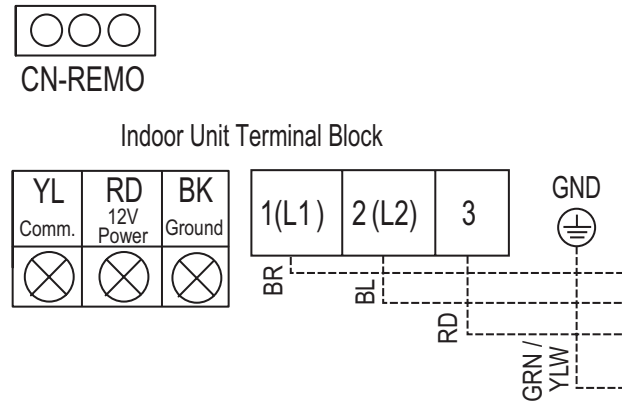

Figure 39: Wired Controller Connection on the Indoor Unit Terminal Block.



### Note:

When using field-supplied controller cable, make sure to connect the yellow to yellow (communications wire), red to red (12V power wire), and black to black (ground wire) terminals from the remote controller to the indoor unit terminal blocks.

# ELECTRICAL CONNECTIONS

## Wired Controller Placement

Wired controllers include a sensor to detect room temperature. To maintain comfort levels in the conditioned space, the wired controller must be installed in a location away from direct sunlight, high humidity, and where it could be directly exposed to cold air. Controller must be installed four (4) to five (5) feet above the floor where its LED display can be read easily, in an area with good air circulation, and where it can detect an average room temperature.

⊘ Do not install the wired controller near or in:

- Drafts or dead spots behind doors and in corners
- Hot or cold air from ducts
- Radiant heat from the sun or appliances
- Concealed pipes and chimneys
- An area where temperatures are uncontrolled, such as an outside wall

Figure 40: Proper Location for the Wired Controller.

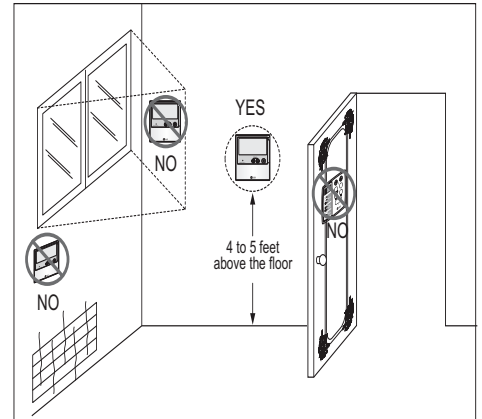

## Hanging the Wired Controller

1. The controller wiring / cable can be installed in one of three directions: top, back, or on the right side. If top or right side installation is desired, remove cable guide grooves on the controller, and then position wiring / cable on applicable side.
2. Choose and mark the area of installation, and then screw the wall plate into place (using the provided parts). Install the controller wall plate to fit the electrical box if one is present. Ensure that no gaps exist between the wall plate and the wall itself.
3. Arrange wiring / cables so as not to interfere with the controller circuitry. Position the wired controller on the wall plate. Snap into place by pressing the bottom part of the wired controller onto the wall plate. Make sure that no gaps exist between the wired controller and the wall plate on all sides.
4. To remove wired controller from the wall plate, insert a screwdriver into the two holes at the bottom. Twist screwdriver to release controller. ⊘ Do not damage the controller components when removing.

Figure 41: Removing the Cable Guide Grooves.

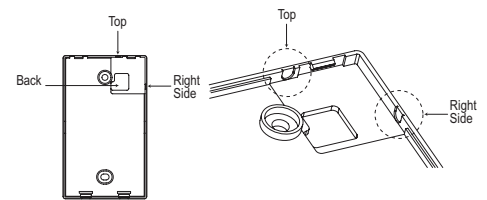

Figure 42: Attaching the Wall Plate.

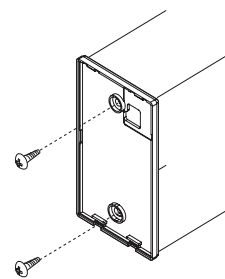
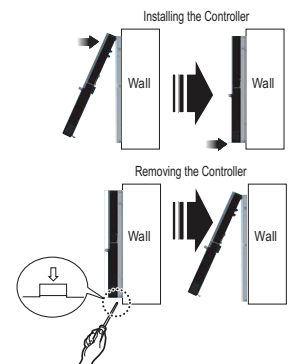

Figure 43: Installing / Removing the Controller.



## Assigning the Thermistor for Temperature Detection

Each indoor unit includes a return air thermistor assigned to sense the temperature. If a wired controller is installed, there is a choice of sensing temperature with either the indoor unit return air thermistor or the thermistor in the wired controller. It is also an option to set both thermistors to sense temperature so that indoor unit bases its operation on the first thermistor to reach the designated temperature differential. For applicable indoor units, an optional Remote Temperature Sensor can be used in lieu of the return air thermistor—either alone or in conjunction with a wired controller thermistor as previously described.

# EXTERNAL STATIC PRESSURE AND AIRFLOW RANGES

## External Static Pressure (ESP) Default Settings (NJ frame)

Table 16: ESP Setting Values (NJ frame).

Model Number	Air Volume*		
	High	Medium	Low
LVN181HV4	640	580	480
LVN241HV4	710	640	480
LVN361HV4	990	880	800

\*Installer settings available to change the CFM to 10% above or 10% below the values mentioned in the above table.

## External Static Pressure Setting Values (NK frame)

Figure 44: ESP Setting Values (NK frame).

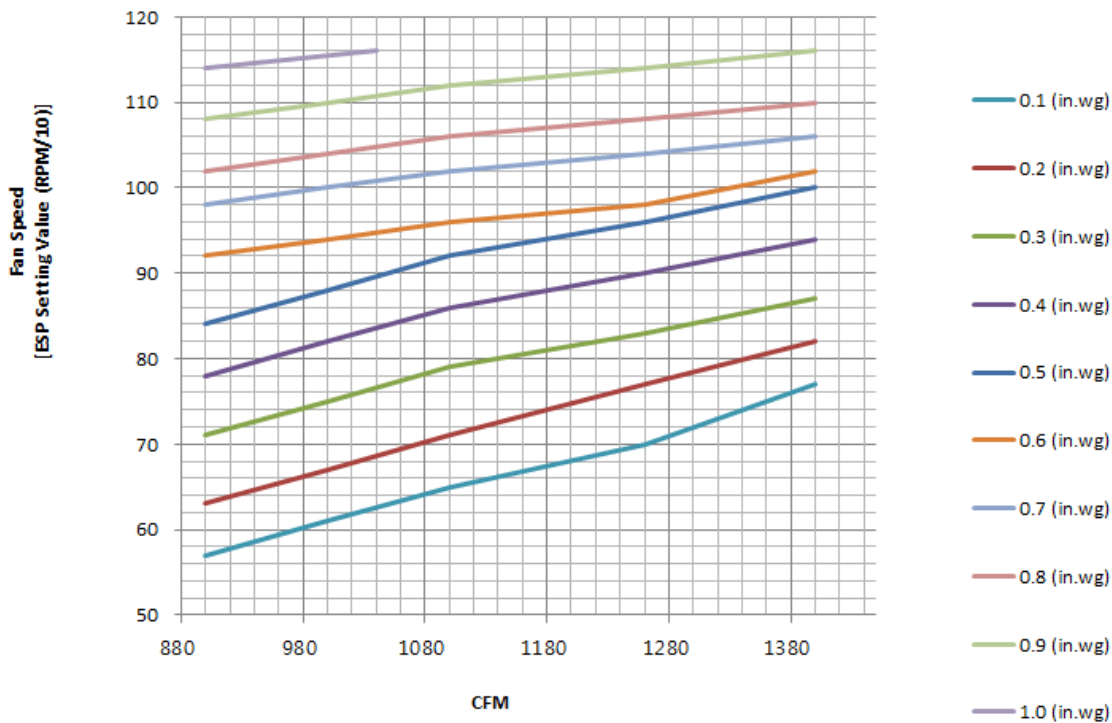

# EXTERNAL STATIC PRESSURE AND AIRFLOW RANGES

## IDU External Static Pressure Setting Values

Table 17: Vertical Air Handling Unit Indoor Unit External Static Pressure and Air Flow Tables.

Static Pressure (in. wg)			0.1	0.2	0.3	0.4	0.5	0.6	0.7	0.8	0.9	1
Model No. / Nominal Capacity of System (Btu/h)	Airflow Rate / CFM		Setting Value (in. WG) <sup>1</sup>									
LVN420HV / 42,000	High	1,260	70	77	83	90	96	98	104	108	116*	—
	Mid	1,100	65	71	79	86	92	96	102	106	114	—
	Low	1,000	61	67	75	82	88	94	100	104	112	116*
LVN480HV / 48,000	High	1,400	77	82	87	94	100	102	106	110	116*	—
	Mid	1,260	70	77	83	90	96	98	104	108	114	116*
	Low	1,000	61	67	75	82	88	94	100	104	112	116*

<sup>1</sup> Unless otherwise noted, vertical air handling units are UL listed up to 0.5 in. wg total static pressure, including coil, case, duct work pressure drop, air filter, and largest kW size heater. Internal static pressure includes coil and case only.

\* Airflow rate (CFM) decreases by 3% per 0.1 in. wg.

Factory default status is 0.3 in wg.

Factory default is high static pressure.

### Note:

- If the ESP is set incorrectly, the air conditioning may malfunction.
- To get the desired air flow and external static pressure combination, use the setting value from the table. Using a setting value other than the values listed in the table will not provide the desired combination.



# EXTERNAL STATIC PRESSURE AND AIRFLOW RANGES

## Air Filter Static Pressure Drop Factors

Table 18: Air Filter Static Pressure Drop Factors.

Capacity (kBtu/h [tons])	Flow Rate (CFM)	Static Pressure Drop (in wg)
18 (1.5)	High (640)	-0.04
	Middle(580)	-0.04
	Low (480)	-0.04
24 (2.0)	High (710)	-0.04
	Middle(640)	-0.04
	Low (480)	-0.04
36 (3.0)	High (990)	-0.08
	Middle(880)	-0.08
	Low (800)	-0.08
42 (3.5)	High (1260)	-0.09
	Middle(1100)	-0.08
	Low (1000)	-0.08
48 (4.0)	High (1400)	-0.09
	Middle(1260)	-0.09
	Low (1000)	-0.08

If the air filter has been installed, the ESP value has to be set.

For every increase in static pressure by 0.01 in. wg, the ESP value must be increased by 1.

## Minimum Airflow by Heater Capacity

Table 19: Minimum Airflow by Heater Capacity.

Capacity (kBtu/h [tons])	Heater Capacity (kW)			
	3, 5	8, 10	15	20
18 (1.5)	480	480	Not available	Not available
24 (2.0)	480	480	Not available	Not available
36 (3.0)	900	900	Not available	Not available
42 (3.5)	1000	1000	1000	1000
48 (4.0)	1000	1000	1000	1000

Airflow rates in the table above are listed in CFM.

### **⚠️ WARNING**

⊘ Do not operate with less than the minimum airflow. If an airflow is used below the minimum, there is a risk of fire, which may lead to physical injury or death.

### **Note:**

⊘ Do not operate with less than the minimum airflow. If an airflow is used below the minimum, there is a risk of damage to the product.

# EXTERNAL STATIC PRESSURE AND AIRFLOW RANGES

## Electric Heater Static Pressure Drop Factors

Table 20: Electric Heater Static Pressure Drop Factors.

Heater Capacity (kW)	Static Pressure Drop (in. wg)
0	0
3, 5	-0.01
8, 10	-0.02
15	-0.03
20	-0.04

in wg = inch water gauge

If the electric heater has been installed, then the ESP value has to be set.

For every increase in static pressure by 0.01 in wg, the ESP value must be increased by 1.

If the ESP setting value is inappropriate, the provided safety device will turn the heater off according to the airflow.

## Down Flow (optional) Static Pressure Drop Factors

Table 21: Down Flow Static Pressure Drop Factors.

Capacity (kBtu/h [tons])	Flow Rate (CFM)	Static Pressure Drop (in wg)
18 (1.5)	High (640)	-0.04
	Middle (580)	-0.04
	Low (480)	-0.04
24 (2.0)	High (710)	-0.04
	Middle (640)	-0.04
	Low (480)	-0.04
36 (3.0)	High (990)	-0.09
	Middle (880)	-0.09
	Low (800)	-0.09
42 (3.5)	High (1260)	-0.09
	Middle (1100)	-0.09
	Low (1000)	-0.09
48 (4.0)	High (1400)	-0.09
	Middle (1260)	-0.09
	Low (1000)	-0.09

If the air filter has been installed, the ESP value has to be set.

For every increase in static pressure by 0.01 in. wc, the ESP value must be increased by 1.

# EXTERNAL STATIC PRESSURE AND AIRFLOW RANGES

## Down Flow - Air Filter (optional) Static Pressure Drop Factors

Table 22: Down Flow - Air Filter Static Pressure Drop Factors.

Capacity (kBtu/h [tons])	Flow Rate (CFM)	Static Pressure Drop (in wg)
18 (1.5)	High (640)	-0.04
	Middle(580)	-0.04
	Low (480)	-0.04
24 (2.0)	High (710)	-0.04
	Middle(640)	-0.04
	Low (480)	-0.04
36 (3.0)	High (990)	-0.06
	Middle(880)	-0.06
	Low (800)	-0.06
42 (3.5)	High (1260)	-0.07
	Middle(1100)	-0.06
	Low (1000)	-0.06
48 (4.0)	High (1400)	-0.07
	Middle(1260)	-0.07
	Low (1000)	-0.06

If the air filter has been installed, the ESP value has to be set.

For every increase in static pressure by 0.01 in. wc, the ESP value must be increased by 1.

## Down Flow - Internal Electric Heater Static Pressure Drop Factors

Table 23: Internal Electric Heater Static Pressure Drop Factors.

Heater Capacity (kW)	Static Pressure Drop (in. wg)
0	0
3, 5	-0.01
8, 10	-0.01
15	-0.01
20	-0.01

in. wc = inch water column, inAq

If the internal electric heater has been installed, then the ESP value has to be set.

For every increase in static pressure by 0.01 in WC, the ESP value must be increased by 1.

If the ESP setting value is inappropriate, the provided safety device will turn the heater off according to the airflow.

# ACCESSORIES

## Electric Heater

Table 24: Electric Heater Capacities for Vertical Air Handling Units.

Accessory	Model Number
3kW Electric Heater	ANEH033B1
5kW Electric Heater	ANEH053B1
8kW Electric Heater	ANEH083B2
10kW Electric Heater	ANEH103B2
15kW Electric Heater	ANEH153B2
20kW Electric Heater	ANEH203B2

Figure 45: Electric Heater.

### Example: 5kW Capacity Heater

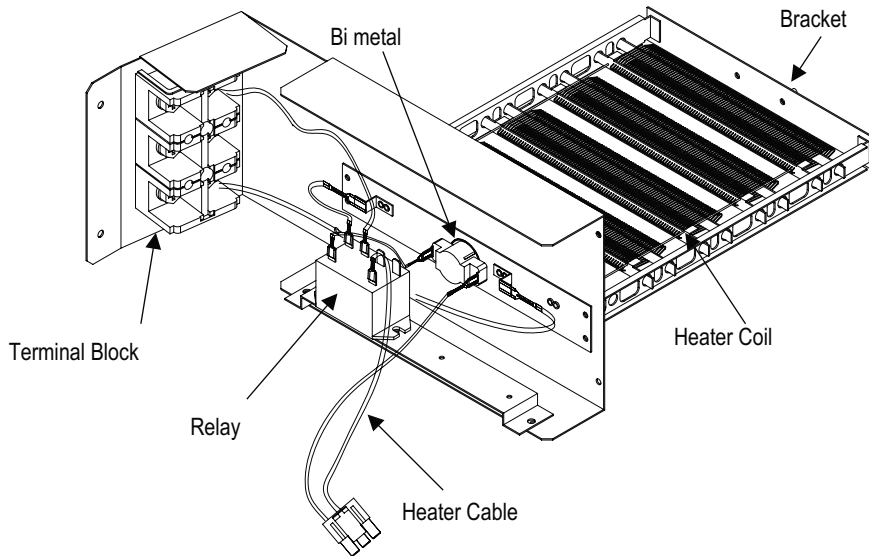

**Note:**

Image shown above may vary depending on model capacity.

Table 25: Electric Heater Capacities.

Indoor Unit Model No. / Capacity (MBh)	Model Number / Heater Capacity					
	ANEH033B1 (3kW)	ANEH053B1 (5kW)	ANEH083B2 (8kW)	ANEH103B2 (10kW)	ANEH153B2 (15kW)	ANEH203B2 (20kW)
LVN181HV4 (18)	√	√	√	√	X	X
LVN241HV4 (24)	√	√	√	√	X	X
LVN361HV4 (36)	√	√	√	√	X	X
LVN420HV (42)	√	√	√	√	√	√
LVN480HV (48)	√	√	√	√	√	√

√ = Standard feature

X = Not Available

## Drain Pan Heater

Figure 46: Drain Pan Heater.



Table 26: Drain Pan Heater Capacities.

IDU	ODU	Heater kW	Accessory Model	Note
LVN181HV4	LUU189HV	120 W	PQSH1200	Optional
LVN241HV4	LUU249HV	120 W	PQSH1200	Optional
LVN361HV4	LUU369HV	120 W	PQSH1200	Optional
LVN420HV	LUU428HV	120 W	PQSH1200	Optional
LVN480HV	LUU488HV	120 W	PQSH1200	Optional

# ACCESSORIES

## LG Monitoring View (LGMV) Diagnostic Software and Cable

LGMV software allows the service technician or commissioning agent to connect a computer USB port to the outdoor unit main printed circuit board (PCB) using an accessory cable without the need for a separate interface device. The main screen for LGMV allows user to view the following real time data on one screen:

- Actual inverter compressor speed
- Target inverter compressor speed
- Actual outdoor fan speed
- Target outdoor unit fan speed
- Actual superheat
- Target superheat
- Actual subcooler circuit superheat
- Target subcooler circuit superheat
- Main EEV position
- Subcooling EEV position
- Inverter compressor current transducer value
- Outdoor air temperature
- Actual high pressure/saturation temperature
- Actual low pressure/saturation temperature
- Suction temperature
- Inverter compressor discharge temperature
- Constant speed compressor discharge temperature
- temperature
- Front outdoor coil pipe temperature
- Back outdoor coil pipe temperature
- Liquid line pipe temperature
- Subcooler inlet temperature
- Subcooler outlet temperature
- Average indoor unit (IDU) pipe temperature
- Inverter compressor operation indicator light
- Four-way reversing valve operation indicator light
- Pressure graph showing actual low pressure and actual high pressure levels
- Error code display
- Operating mode indicator
- Target high pressure
- Target low pressure
- PCB (printed circuit board) version
- Software version
- Installer name
- Model no. of outdoor units
- Site name
- Total number of connected indoor units
- Communication indicator lights
- Indoor unit capacity
- Indoor unit operating mode
- Indoor unit fan speed
- Indoor unit EEV position
- Indoor unit room temperature
- Indoor unit inlet pipe temperature
- Indoor unit outlet pipe temperature
- Indoor unit error code



Additional screens can be accessed by tabs on the main screen:

1. Cycleview: Graphic of internal components including:
  - Compressors showing actual speeds
  - EEVs
  - Indoor Units
  - Liquid injection valves
  - Temperature and pressure sensors
  - Four-way reversing valve
  - Outdoor fans showing status and speeds
2. Graph: Full screen graph of actual high and low pressures and high and low pressure limits. A sliding bar enables user to go back in time and view data.
3. Control IDU: Enables user to turn on all IDU's default setpoints of 86°F in heat mode or 64°F in cool mode.
4. Setting: Converts metric values to imperial values.
5. Making Data: Recording of real time data to a separate file created to be stored on the user's computer.
6. Loading Data: Recorded data from a saved ".CSV" file can be loaded to create an LGMV session.
7. Electrical Data: The lower half of main screen is changed to show the following:
  - Inverter compressor
    - Amps
    - Volts
    - Power Hz
    - Inverter control board fan Hz
  - Constant compressor
    - Current transducer value
    - Phase

Figure 47: Sample Cycleview.

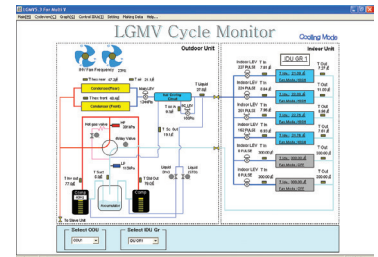

In lieu of connecting to the outdoor unit, user has the option to connect to the indoor unit with the use of a USB to RS-485 connector kit. When connected through the indoor unit, user will not be able to record data.

This software can be used to both commission new systems and troubleshoot existing systems. LGMV data can be recorded to a ".CSV" file and emailed to an LG representative to assist with diagnostic evaluations.

### Recommended Minimum PC Configuration:

- CPU: Pentium® IV 1.6 GHz
- Operating System: Windows® NT/2000/XP/Vista
- Main Memory: 256 MB
- Hard Disk: 600 MB when operating
- Web Browser: Internet Explorer® 5.0

**LGMV is available in different formats, including Mobile LGMV, which is a app for use on wireless devices. Contact your LG Sales Representative for more information.**

## LG Smart Inverter Monitoring System (SIMS)

SIMS can be used to display and graph operational data for single zone systems and respective components (indoor unit and outdoor unit). SIMS also displays error codes and a troubleshooting guide. SIMS consists of a hardware Wireless Local Area Network (WLAN) module, an interface cable, and a free downloadable application (app) for iOS® or Android™. The user must supply either an Apple® or an Android smart phone; SIMS is not optimized for tablets, and only be used with LG single zone and Multi F systems.

Only trained HVAC service technicians familiar with variable refrigerant flow (VRF) systems in general and with LG's DFS products can use SIMS. The technician must understand inverter air conditioning operation cycles, the meaning of the data displayed by SIMS, and how to use the data to troubleshoot the system.

*iOS is a registered trademark of Cisco in the U.S. and other countries. Android is a trademark of Google Inc. Apple is a trademark of Apple Inc., registered in the U.S. and other countries.*

**Contact your LG Sales Representative for system requirements, the latest version of SIMS, how to download the app, or other information.**

Figure 48: LG SIMS WLAN Module.



## LG Smart ThinQ

LG Smart ThinQ is an optional Wi-Fi module, along with a free smart phone app that provides monitoring and remote control capabilities for certain LG single zone systems. The app has the following features and benefits:

- Sign in to the app using LG credentials, or using Google® or Facebook® login credentials. Users only have to log in to the app once; the app remembers login details for subsequent logins.
- View current temperature settings of the air conditioning unit and change temperature, fan speed, and air flow direction from anywhere in the house or at a remote location (through the use of wireless connection). Multiple users can control the household air conditioning unit remotely.
- Monitor filter usage of the unit.
- Set up weekly schedules to start and stop air conditioner activity.
- Set up the unit to run in different Modes, depending on the user's schedule. Set up specific temperatures for when the user is home, away on vacation, or sleeping.
- Troubleshoot problems, and view tips on general maintenance of the system using the Smart Diagnosis function.

*\*Google is a registered trademark of Google Inc.; Facebook is a registered trademark of Facebook.*

**Contact your LG Sales Representative or visit [www.lg-dfs.com](http://www.lg-dfs.com) for system requirements, how to download the app, a user's manual, or other information.**

Figure 49: Example of an LG Smart ThinQ Screen (appearances may differ depending on version of software).

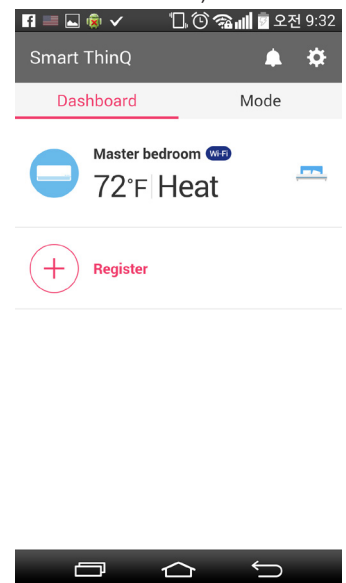

# VERTICAL AIR HANDLING UNIT PERFORMANCE DATA

[Cooling Capacity Data on page 57](#)

[Heating Capacity Data on page 62](#)

[Maximum Heating Capacity Data on page 67](#)

[Equipment Selection Procedure on page 72](#)



# PERFORMANCE DATA

## Cooling Capacity Tables

### Cooling Capacity Table for LV181HV4 (LUU189HV + LVN181HV4)

Table 27: Cooling Capacity Table for LUU189HV + LVN181HV4.

Outdoor Air Temp. (°F DB)	Indoor Air Temp. °F DB / °F WB																	
	68 / 57			72 / 61			77 / 64			80 / 67			86 / 72			90 / 75		
	TC	SHC	PI	TC	SHC	PI	TC	SHC	PI	TC	SHC	PI	TC	SHC	PI	TC	SHC	PI
-4	17.70	13.35	0.80	18.80	14.10	0.83	19.89	13.66	0.86	20.69	13.94	0.87	22.09	14.06	0.88	23.19	14.33	0.90
-0.4	17.69	13.43	0.81	18.79	14.19	0.84	19.88	13.74	0.87	20.68	14.03	0.88	22.08	14.14	0.89	23.18	14.41	0.91
5	17.67	13.55	0.82	18.77	14.31	0.85	19.87	13.86	0.88	20.66	14.15	0.89	22.06	14.27	0.91	23.16	14.54	0.93
10	17.66	13.65	0.83	18.76	14.42	0.86	19.85	13.97	0.89	20.64	14.26	0.90	22.05	14.38	0.92	23.14	14.65	0.94
15	17.65	13.76	0.84	18.74	14.54	0.88	19.84	14.08	0.91	20.63	14.37	0.92	22.03	14.49	0.94	23.12	14.77	0.95
20	17.63	13.87	0.86	18.73	14.65	0.89	19.82	14.19	0.92	20.61	14.49	0.93	22.01	14.61	0.95	23.11	14.88	0.97
25	17.62	13.98	0.87	18.71	14.77	0.90	19.81	14.30	0.93	20.60	14.60	0.94	22.00	14.72	0.96	23.09	15.00	0.98
30	17.60	14.08	0.88	18.70	14.88	0.91	19.79	14.41	0.95	20.58	14.71	0.96	21.98	14.83	0.98	23.07	15.11	1.00
35	17.59	14.19	0.89	18.68	14.99	0.93	19.78	14.52	0.96	20.57	14.82	0.97	21.96	14.95	0.99	23.05	15.23	1.01
40	17.58	14.30	0.91	18.67	15.10	0.94	19.76	14.63	0.97	20.55	14.93	0.98	21.94	15.06	1.00	23.04	15.34	1.02
45	17.56	14.41	0.92	18.66	15.22	0.95	19.75	14.73	0.99	20.53	15.04	1.00	21.93	15.17	1.02	23.02	15.46	1.04
50	17.55	14.51	0.93	18.64	15.33	0.96	19.73	14.84	1.00	20.52	15.16	1.01	21.91	15.28	1.03	23.00	15.57	1.05
55	17.54	14.62	0.94	18.63	15.44	0.98	19.72	14.95	1.01	20.50	15.27	1.02	21.89	15.40	1.04	22.98	15.69	1.06
60	17.52	14.72	0.95	18.61	15.55	0.99	19.70	15.06	1.03	20.49	15.38	1.04	21.88	15.51	1.06	22.97	15.80	1.08
65	17.51	14.83	0.97	18.60	15.67	1.00	19.69	15.17	1.04	20.47	15.49	1.05	21.86	15.62	1.07	22.95	15.91	1.09
70	17.50	14.94	0.98	18.58	15.78	1.01	19.67	15.28	1.05	20.46	15.60	1.06	21.84	15.73	1.08	22.93	16.03	1.10
75	17.08	14.69	1.03	18.16	15.54	1.07	19.24	15.06	1.11	20.03	15.39	1.12	21.41	15.54	1.14	22.50	15.85	1.16
80	16.66	14.44	1.08	17.74	15.29	1.12	18.82	14.84	1.16	19.60	15.18	1.18	20.98	15.34	1.20	22.06	15.66	1.22
85	16.24	14.18	1.14	17.32	15.04	1.18	18.40	14.61	1.22	19.17	14.95	1.24	20.55	15.14	1.26	21.63	15.46	1.28
90	15.82	13.91	1.19	16.90	14.77	1.23	17.97	14.37	1.28	18.75	14.72	1.29	20.12	14.92	1.32	21.20	15.26	1.34
95	15.37	13.76	1.24	16.44	14.64	1.29	17.51	14.27	1.33	<b>18.00</b>	<b>14.40</b>	<b>1.35</b>	19.65	14.84	1.38	20.72	15.19	1.40
100	14.99	13.39	1.30	16.06	14.27	1.34	17.13	13.92	1.39	17.77	14.18	1.41	19.28	14.52	1.43	20.35	14.88	1.46
105	14.62	13.02	1.35	15.69	13.90	1.40	16.76	13.59	1.45	17.53	13.95	1.46	18.90	14.21	1.49	19.97	14.57	1.52
110	14.24	12.58	1.40	15.32	13.45	1.45	16.39	13.17	1.50	17.16	13.54	1.52	18.53	13.80	1.55	19.60	14.17	1.58
115	13.87	12.20	1.45	14.94	13.07	1.51	16.01	12.82	1.56	16.79	13.19	1.58	18.15	13.47	1.61	19.22	13.85	1.64
118	13.65	12.11	1.49	14.72	12.99	1.54	15.79	12.75	1.60	16.56	13.13	1.61	17.93	13.43	1.64	19.00	13.81	1.68
122	13.57	12.08	1.53	14.64	12.97	1.58	15.71	12.73	1.64	16.49	13.11	1.66	17.85	13.41	1.69	18.92	13.80	1.72

Product Data

- DB: Dry Bulb Temperature (°F) WB: Wet Bulb Temperature (°F) TC: Total Capacity (kBtu/h)  
 SHC: Sensible Capacity (kBtu/h) PI: Power Input (kW) (includes compressor, indoor fan motor and outdoor fan motor)
1. All capacities are net, evaporator fan motor heat is deducted.
  2. Cooling operating range with the Low Ambient Baffle Kit (sold separately) is -4°F to +122°F.
  3. Grey shading indicates reference data. When operating the unit at this temperature, these values can be different by discontinuous operation.
  4. Direct interpolation is permissible.  Do not extrapolate.

Nominal capacity as rated: 0 ft. above sea level with 25 ft. of refrigerant piping. 0 ft. level difference between outdoor and indoor units.  
 Nominal cooling capacity rating obtained with air entering the indoor unit at 80°F dry bulb (DB) and 67°F wet bulb (WB), and outdoor ambient conditions of 95°F dry bulb (DB) and 75°F wet bulb (WB).



# PERFORMANCE DATA

## Cooling Capacity Tables

### Cooling Capacity Table for LV241HV4 (LUU249HV + LVN241HV4)

Table 28: Cooling Capacity Table for LUU249HV + LVN241HV4.

Outdoor Air Temp. (°F DB)	Indoor Air Temp. °F DB / °F WB																	
	68 / 57			72 / 61			77 / 64			80 / 67			86 / 72			90 / 75		
	TC	SHC	PI	TC	SHC	PI	TC	SHC	PI	TC	SHC	PI	TC	SHC	PI	TC	SHC	PI
-4	23.60	17.76	1.18	25.06	18.76	1.23	26.53	18.16	1.27	27.58	18.55	1.29	29.46	18.70	1.31	30.92	19.06	1.34
-0.4	23.58	17.86	1.20	25.05	18.87	1.24	26.51	18.27	1.29	27.57	18.65	1.30	29.44	18.81	1.32	30.91	19.17	1.35
5	23.56	18.02	1.22	25.03	19.03	1.26	26.49	18.43	1.31	27.55	18.82	1.32	29.42	18.98	1.35	30.88	19.33	1.37
10	23.55	18.16	1.23	25.01	19.18	1.28	26.47	18.58	1.33	27.53	18.97	1.34	29.39	19.13	1.37	30.86	19.49	1.39
15	23.53	18.30	1.25	24.99	19.34	1.30	26.45	18.72	1.34	27.50	19.12	1.36	29.37	19.28	1.39	30.83	19.64	1.41
20	23.51	18.45	1.27	24.97	19.49	1.32	26.43	18.87	1.36	27.48	19.27	1.38	29.35	19.43	1.41	30.81	19.80	1.43
25	23.49	18.59	1.29	24.95	19.64	1.33	26.41	19.01	1.38	27.46	19.42	1.40	29.33	19.58	1.43	30.79	19.95	1.45
30	23.47	18.73	1.31	24.93	19.79	1.35	26.39	19.16	1.40	27.44	19.56	1.42	29.30	19.73	1.45	30.76	20.10	1.47
35	23.46	18.88	1.32	24.91	19.94	1.37	26.37	19.31	1.42	27.42	19.71	1.44	29.28	19.88	1.47	30.74	20.26	1.49
40	23.44	19.02	1.34	24.89	20.09	1.39	26.35	19.45	1.44	27.40	19.86	1.46	29.26	20.03	1.49	30.72	20.41	1.52
45	23.42	19.16	1.36	24.87	20.24	1.41	26.33	19.60	1.46	27.38	20.01	1.48	29.24	20.18	1.51	30.69	20.56	1.54
50	23.40	19.30	1.38	24.85	20.39	1.43	26.31	19.74	1.48	27.36	20.16	1.50	29.21	20.33	1.52	30.67	20.71	1.56
55	23.38	19.44	1.40	24.84	20.54	1.45	26.29	19.89	1.50	27.34	20.30	1.52	29.19	20.48	1.54	30.64	20.86	1.58
60	23.37	19.58	1.41	24.82	20.69	1.47	26.27	20.03	1.52	27.32	20.45	1.54	29.17	20.62	1.56	30.62	21.02	1.60
65	23.35	19.72	1.43	24.80	20.84	1.48	26.25	20.17	1.54	27.29	20.60	1.56	29.15	20.77	1.58	30.60	21.17	1.62
70	23.33	19.86	1.45	24.78	20.98	1.50	26.23	20.32	1.56	27.27	20.75	1.58	29.13	20.92	1.60	30.57	21.32	1.64
75	22.77	19.54	1.53	24.21	20.67	1.58	25.66	20.03	1.64	26.70	20.47	1.66	28.55	20.67	1.69	29.99	21.08	1.73
80	22.21	19.20	1.61	23.65	20.34	1.66	25.09	19.74	1.73	26.13	20.19	1.75	27.97	20.41	1.78	29.42	20.83	1.81
85	21.65	18.85	1.68	23.09	20.00	1.75	24.53	19.43	1.81	25.57	19.89	1.83	27.40	20.13	1.86	28.84	20.57	1.90
90	21.09	18.50	1.76	22.53	19.65	1.83	23.96	19.12	1.89	25.00	19.58	1.92	26.83	19.85	1.95	28.27	20.30	1.99
95	20.49	18.30	1.84	21.92	19.47	1.91	23.35	18.97	1.98	<b>24.00</b>	<b>19.15</b>	<b>2.00</b>	26.20	19.74	2.04	27.63	20.21	2.08
100	19.99	17.81	1.92	21.42	18.98	1.99	22.85	18.52	2.06	23.69	18.86	2.08	25.70	19.32	2.12	27.13	19.79	2.17
105	19.49	17.32	2.00	20.92	18.49	2.07	22.35	18.07	2.15	23.38	18.56	2.17	25.20	18.89	2.21	26.63	19.38	2.26
110	18.99	16.73	2.07	20.42	17.89	2.15	21.85	17.51	2.23	22.88	18.00	2.25	24.70	18.36	2.30	26.13	18.85	2.34
115	18.49	16.23	2.15	19.92	17.39	2.23	21.35	17.05	2.31	22.38	17.55	2.34	24.20	17.92	2.38	25.63	18.42	2.43
118	18.19	16.11	2.20	19.62	17.28	2.28	21.05	16.96	2.36	22.08	17.47	2.39	23.90	17.86	2.44	25.33	18.37	2.48
122	18.10	16.07	2.26	19.52	17.25	2.35	20.95	16.93	2.43	21.98	17.44	2.46	23.81	17.84	2.50	25.23	18.35	2.56

- DB: Dry Bulb Temperature (°F) WB: Wet Bulb Temperature (°F) TC: Total Capacity (kBtu/h)  
 SHC: Sensible Capacity (kBtu/h) PI: Power Input (kW) (includes compressor, indoor fan motor and outdoor fan motor)
- All capacities are net, evaporator fan motor heat is deducted.
  - Cooling operating range with the Low Ambient Baffle Kit (sold separately) is -4°F to +122°F.
  - Grey shading indicates reference data. When operating the unit at this temperature, these values can be different by discontinuous operation.
  - Direct interpolation is permissible.  Do not extrapolate.

Nominal capacity as rated: 0 ft. above sea level with 25 ft. of refrigerant piping. 0 ft. level difference between outdoor and indoor units.  
 Nominal cooling capacity rating obtained with air entering the indoor unit at 80°F dry bulb (DB) and 67°F wet bulb (WB), and outdoor ambient conditions of 95°F dry bulb (DB) and 75°F wet bulb (WB).



# PERFORMANCE DATA

## Cooling Capacity Tables

### Cooling Capacity Table for LV361HV4 (LUU369HV + LVN361HV4)

Table 29: Cooling Capacity Table for LUU369HV + LVN361HV4.

Outdoor Air Temp. (°F DB)	Indoor Air Temp. °F DB / °F WB																	
	68 / 57			72 / 61			77 / 64			80 / 67			86 / 72			90 / 75		
	TC	SHC	PI	TC	SHC	PI	TC	SHC	PI	TC	SHC	PI	TC	SHC	PI	TC	SHC	PI
-4	35.39	24.53	1.93	37.59	25.92	2.01	39.79	25.09	2.08	41.38	25.62	2.10	44.19	25.84	2.14	46.38	26.33	2.18
-0.4	35.37	24.68	1.96	37.57	26.07	2.03	39.77	25.24	2.10	41.35	25.77	2.13	44.16	25.99	2.17	46.36	26.48	2.21
5	35.34	24.89	1.99	37.54	26.30	2.06	39.73	25.46	2.14	41.32	26.00	2.16	44.12	26.22	2.20	46.32	26.71	2.24
10	35.32	25.09	2.02	37.51	26.50	2.09	39.70	25.66	2.17	41.29	26.20	2.19	44.09	26.43	2.23	46.28	26.93	2.28
15	35.29	25.29	2.05	37.48	26.71	2.12	39.67	25.87	2.20	41.26	26.41	2.22	44.06	26.63	2.27	46.25	27.14	2.31
20	35.26	25.49	2.08	37.45	26.92	2.15	39.64	26.07	2.23	41.23	26.62	2.26	44.02	26.84	2.30	46.21	27.35	2.34
25	35.24	25.68	2.11	37.43	27.13	2.18	39.61	26.27	2.26	41.19	26.82	2.29	43.99	27.05	2.33	46.18	27.56	2.38
30	35.21	25.88	2.13	37.40	27.34	2.21	39.58	26.47	2.29	41.16	27.03	2.32	43.96	27.26	2.36	46.14	27.77	2.41
35	35.18	26.08	2.16	37.37	27.55	2.24	39.55	26.67	2.32	41.13	27.23	2.35	43.92	27.46	2.40	46.11	27.98	2.44
40	35.16	26.27	2.19	37.34	27.75	2.27	39.52	26.87	2.36	41.10	27.44	2.38	43.89	27.67	2.43	46.07	28.20	2.48
45	35.13	26.47	2.22	37.31	27.96	2.30	39.49	27.07	2.39	41.07	27.64	2.42	43.86	27.88	2.46	46.04	28.41	2.51
50	35.10	26.67	2.25	37.28	28.17	2.33	39.46	27.27	2.42	41.04	27.85	2.45	43.82	28.08	2.49	46.00	28.62	2.54
55	35.08	26.86	2.28	37.25	28.37	2.36	39.43	27.47	2.45	41.01	28.05	2.48	43.79	28.29	2.53	45.97	28.83	2.58
60	35.05	27.06	2.31	37.23	28.58	2.40	39.40	27.67	2.48	40.97	28.26	2.51	43.76	28.49	2.56	45.93	29.03	2.61
65	35.02	27.25	2.34	37.20	28.79	2.43	39.37	27.87	2.51	40.94	28.46	2.54	43.72	28.70	2.59	45.90	29.24	2.64
70	34.99	27.44	2.37	37.17	28.99	2.46	39.34	28.07	2.55	40.91	28.66	2.58	43.69	28.90	2.62	45.86	29.45	2.68
75	34.15	26.99	2.50	36.32	28.55	2.59	38.49	27.68	2.68	40.05	28.28	2.71	42.82	28.55	2.77	44.99	29.12	2.82
80	33.31	26.53	2.63	35.47	28.10	2.72	37.64	27.27	2.82	39.20	27.89	2.85	41.96	28.19	2.91	44.12	28.78	2.97
85	32.48	26.05	2.75	34.63	27.63	2.85	36.79	26.85	2.96	38.35	27.48	2.99	41.10	27.81	3.05	43.26	28.41	3.11
90	31.64	25.56	2.88	33.79	27.15	2.99	35.94	26.41	3.10	37.50	27.06	3.13	40.25	27.42	3.19	42.40	28.04	3.25
95	30.74	25.29	3.01	32.88	26.90	3.12	35.02	26.21	3.23	<b>36.00</b>	<b>26.46</b>	<b>3.27</b>	39.30	27.28	3.33	41.44	27.92	3.40
100	29.99	24.61	3.14	32.13	26.22	3.25	34.27	25.59	3.37	35.53	26.05	3.41	38.55	26.69	3.47	40.69	27.34	3.54
105	29.24	23.93	3.26	31.38	25.55	3.38	33.52	24.96	3.51	35.07	25.64	3.55	37.80	26.10	3.61	39.94	26.77	3.69
110	28.49	23.12	3.39	30.63	24.72	3.52	32.77	24.19	3.64	34.32	24.87	3.69	37.05	25.36	3.76	39.20	26.04	3.83
115	27.74	22.42	3.52	29.88	24.02	3.65	32.02	23.55	3.78	33.57	24.24	3.83	36.31	24.76	3.90	38.45	25.45	3.98
118	27.29	22.26	3.60	29.43	23.88	3.73	31.57	23.43	3.86	33.12	24.13	3.91	35.86	24.67	3.98	38.00	25.38	4.06
122	27.14	22.21	3.70	29.28	23.83	3.83	31.43	23.39	3.97	32.97	24.10	4.02	35.71	24.64	4.10	37.85	25.35	4.18

Product Data

- DB: Dry Bulb Temperature (°F) WB: Wet Bulb Temperature (°F) TC: Total Capacity (kBtu/h)  
 SHC: Sensible Capacity (kBtu/h) PI: Power Input (kW) (includes compressor, indoor fan motor and outdoor fan motor)
- All capacities are net, evaporator fan motor heat is deducted.
  - Cooling operating range with the Low Ambient Baffle Kit (sold separately) is -4°F to +122°F.
  - Grey shading indicates reference data. When operating the unit at this temperature, these values can be different by discontinuous operation.
  - Direct interpolation is permissible. Do not extrapolate.

Nominal capacity as rated: 0 ft. above sea level with 25 ft. of refrigerant piping. 0 ft. level difference between outdoor and indoor units.  
 Nominal cooling capacity rating obtained with air entering the indoor unit at 80°F dry bulb (DB) and 67°F wet bulb (WB), and outdoor ambient conditions of 95°F dry bulb (DB) and 75°F wet bulb (WB).



# PERFORMANCE DATA

## Cooling Capacity Tables

### Cooling Capacity Table for LV420HV (LUU428HV + LVN420HV)

Table 30: Cooling Capacity Table for LUU428HV + LVN420HV.

Outdoor Air Temp. (°F DB)	Indoor Air Temp. °F DB / °F WB																	
	68 / 57			72 / 61			77 / 64			80 / 67			86 / 72			90 / 75		
	TC	SHC	PI	TC	SHC	PI	TC	SHC	PI	TC	SHC	PI	TC	SHC	PI	TC	SHC	PI
-4	41.29	29.99	2.25	43.86	31.68	2.33	46.42	30.67	2.42	48.27	31.32	2.44	51.55	31.58	2.49	54.11	32.18	2.54
0	41.27	30.16	2.27	43.83	31.86	2.36	46.40	30.85	2.44	48.25	31.50	2.47	51.52	31.77	2.52	54.08	32.37	2.57
5	41.24	30.42	2.31	43.80	32.14	2.39	46.36	31.12	2.48	48.21	31.77	2.51	51.48	32.04	2.56	54.04	32.65	2.61
10	41.20	30.67	2.34	43.76	32.39	2.43	46.32	31.37	2.52	48.17	32.03	2.55	51.44	32.30	2.59	54.00	32.91	2.65
15	41.17	30.91	2.38	43.73	32.65	2.46	46.29	31.61	2.55	48.13	32.28	2.58	51.40	32.55	2.63	53.96	33.17	2.69
20	41.14	31.15	2.41	43.70	32.91	2.50	46.25	31.86	2.59	48.10	32.53	2.62	51.36	32.81	2.67	53.92	33.43	2.72
25	41.11	31.39	2.45	43.66	33.16	2.54	46.22	32.11	2.63	48.06	32.78	2.66	51.32	33.06	2.71	53.88	33.69	2.76
30	41.08	31.63	2.48	43.63	33.41	2.57	46.18	32.35	2.66	48.02	33.04	2.70	51.28	33.31	2.75	53.83	33.95	2.80
35	41.05	31.87	2.51	43.60	33.67	2.61	46.15	32.60	2.70	47.99	33.29	2.73	51.24	33.57	2.78	53.79	34.20	2.84
40	41.02	32.11	2.55	43.56	33.92	2.64	46.11	32.85	2.74	47.95	33.54	2.77	51.20	33.82	2.82	53.75	34.46	2.88
45	40.98	32.35	2.58	43.53	34.18	2.68	46.07	33.09	2.78	47.91	33.79	2.81	51.17	34.07	2.86	53.71	34.72	2.92
50	40.95	32.59	2.62	43.50	34.43	2.71	46.04	33.34	2.81	47.88	34.04	2.84	51.13	34.32	2.90	53.67	34.97	2.96
55	40.92	32.83	2.65	43.46	34.68	2.75	46.00	33.58	2.85	47.84	34.29	2.88	51.09	34.58	2.94	53.63	35.23	2.99
60	40.89	33.07	2.69	43.43	34.93	2.78	45.97	33.82	2.89	47.80	34.54	2.92	51.05	34.83	2.97	53.59	35.49	3.03
65	40.86	33.31	2.72	43.40	35.18	2.82	45.93	34.07	2.92	47.77	34.78	2.96	51.01	35.08	3.01	53.55	35.74	3.07
70	40.83	33.54	2.75	43.36	35.43	2.85	45.90	34.31	2.96	47.73	35.03	2.99	50.97	35.33	3.05	53.50	36.00	3.11
75	39.84	32.99	2.90	42.37	34.90	3.01	44.90	33.83	3.12	46.73	34.57	3.15	49.96	34.90	3.21	52.49	35.59	3.28
80	38.86	32.43	3.05	41.39	34.35	3.16	43.91	33.33	3.28	45.73	34.09	3.32	48.95	34.46	3.38	51.48	35.17	3.45
85	37.89	31.84	3.20	40.41	33.77	3.32	42.92	32.81	3.44	44.74	33.58	3.48	47.96	33.99	3.54	50.47	34.73	3.61
90	36.91	31.23	3.35	39.43	33.18	3.47	41.94	32.28	3.60	43.75	33.07	3.64	46.96	33.52	3.71	49.47	34.27	3.78
95	35.86	30.91	3.50	38.36	32.88	3.62	40.85	32.04	3.76	<b>42.00</b>	<b>32.34</b>	<b>3.80</b>	45.85	33.34	3.87	48.35	34.12	3.95
100	34.98	30.08	3.65	37.48	32.05	3.78	39.98	31.27	3.92	41.46	31.84	3.96	44.98	32.62	4.04	47.47	33.42	4.12
105	34.11	29.25	3.79	36.61	31.22	3.93	39.11	30.51	4.08	40.91	31.34	4.12	44.10	31.90	4.20	46.60	32.72	4.28
110	33.24	28.25	3.94	35.74	30.21	4.09	38.23	29.57	4.24	40.04	30.40	4.28	43.23	31.00	4.36	45.73	31.83	4.45
115	32.37	27.41	4.09	34.86	29.36	4.24	37.36	28.78	4.40	39.17	29.63	4.45	42.36	30.26	4.53	44.86	31.10	4.62
118	31.84	27.21	4.18	34.34	29.18	4.33	36.84	28.64	4.49	38.64	29.50	4.54	41.83	30.16	4.63	44.33	31.02	4.72
122	31.67	27.14	4.30	34.16	29.12	4.46	36.66	28.59	4.62	38.47	29.45	4.67	41.66	30.12	4.76	44.16	30.99	4.86

DB: Dry Bulb Temperature (°F) WB: Wet Bulb Temperature (°F) TC: Total Capacity (kBtu/h)  
 SHC: Sensible Capacity (kBtu/h) PI: Power Input (kW) (includes compressor, indoor fan motor and outdoor fan motor)

- All capacities are net, evaporator fan motor heat is deducted.
- Cooling operating range with the Low Ambient Baffle Kit (sold separately) is -4°F to +122°F.
- Grey shading indicates reference data. When operating the unit at this temperature, these values can be different by discontinuous operation.
- Direct interpolation is permissible.  Do not extrapolate.

Nominal capacity as rated: 0 ft. above sea level with 25 ft. of refrigerant piping. 0 ft. level difference between outdoor and indoor units.  
 Nominal cooling capacity rating obtained with air entering the indoor unit at 80°F dry bulb (DB) and 67°F wet bulb (WB), and outdoor ambient conditions of 95°F dry bulb (DB) and 75°F wet bulb (WB).

# PERFORMANCE DATA

## Cooling Capacity Tables

### Cooling Capacity Table for LV480HV (LUU488HV + LVN480HV)

Table 31: Cooling Capacity Table for LUU488HV + LVN480HV.

Outdoor Air Temp. (°F DB)	Indoor Air Temp. °F DB / °F WB																	
	68 / 57			72 / 61			77 / 64			80 / 67			86 / 72			90 / 75		
	TC	SHC	PI	TC	SHC	PI	TC	SHC	PI	TC	SHC	PI	TC	SHC	PI	TC	SHC	PI
-4	47.19	33.83	2.84	50.12	35.73	2.94	53.05	34.60	3.05	55.17	35.33	3.09	58.91	35.62	3.14	61.84	36.30	3.21
0	47.16	34.02	2.87	50.09	35.94	2.98	53.02	34.80	3.08	55.14	35.53	3.12	58.88	35.83	3.18	61.81	36.51	3.24
5	47.13	34.32	2.92	50.05	36.25	3.02	52.98	35.10	3.13	55.09	35.84	3.17	58.83	36.14	3.23	61.76	36.83	3.29
10	47.09	34.59	2.96	50.01	36.54	3.07	52.94	35.38	3.18	55.05	36.13	3.22	58.79	36.43	3.28	61.71	37.12	3.34
15	47.05	34.87	3.00	49.98	36.83	3.11	52.90	35.66	3.23	55.01	36.41	3.26	58.74	36.72	3.33	61.67	37.41	3.39
20	47.02	35.14	3.05	49.94	37.12	3.16	52.86	35.94	3.27	54.97	36.70	3.31	58.70	37.01	3.37	61.62	37.71	3.44
25	46.98	35.41	3.09	49.90	37.41	3.20	52.82	36.22	3.32	54.93	36.98	3.36	58.65	37.29	3.42	61.57	38.00	3.49
30	46.95	35.68	3.13	49.86	37.69	3.25	52.78	36.50	3.37	54.88	37.26	3.41	58.61	37.58	3.47	61.52	38.29	3.54
35	46.91	35.95	3.18	49.82	37.98	3.29	52.74	36.77	3.41	54.84	37.55	3.45	58.56	37.86	3.52	61.48	38.58	3.59
40	46.87	36.22	3.22	49.79	38.26	3.34	52.70	37.05	3.46	54.80	37.83	3.50	58.52	38.15	3.56	61.43	38.87	3.64
45	46.84	36.49	3.26	49.75	38.55	3.38	52.66	37.33	3.51	54.76	38.11	3.55	58.47	38.43	3.61	61.38	39.16	3.68
50	46.80	36.76	3.31	49.71	38.84	3.43	52.62	37.60	3.55	54.72	38.39	3.59	58.43	38.72	3.66	61.34	39.45	3.73
55	46.77	37.03	3.35	49.67	39.12	3.47	52.58	37.88	3.60	54.67	38.68	3.64	58.38	39.00	3.71	61.29	39.74	3.78
60	46.73	37.30	3.39	49.63	39.40	3.52	52.54	38.15	3.64	54.63	38.96	3.69	58.34	39.29	3.76	61.24	40.03	3.83
65	46.70	37.57	3.44	49.60	39.69	3.56	52.50	38.43	3.69	54.59	39.24	3.73	58.30	39.57	3.80	61.20	40.32	3.88
70	46.66	37.84	3.48	49.56	39.97	3.61	52.46	38.70	3.74	54.55	39.52	3.78	58.25	39.85	3.85	61.15	40.60	3.93
75	45.54	37.22	3.67	48.43	39.36	3.80	51.32	38.16	3.94	53.41	38.99	3.98	57.10	39.37	4.06	59.99	40.15	4.14
80	44.41	36.58	3.85	47.30	38.74	3.99	50.18	37.60	4.14	52.26	38.45	4.19	55.95	38.87	4.27	58.83	39.68	4.35
85	43.30	35.91	4.04	46.18	38.09	4.19	49.05	37.01	4.34	51.13	37.88	4.39	54.81	38.35	4.47	57.68	39.17	4.56
90	42.19	35.23	4.23	45.06	37.43	4.38	47.93	36.42	4.54	50.00	37.30	4.60	53.66	37.81	4.68	56.53	38.66	4.78
95	40.98	34.86	4.42	43.84	37.09	4.58	46.69	36.14	4.75	<b>48.00</b>	<b>36.48</b>	<b>4.80</b>	52.40	37.61	4.89	55.25	38.49	4.99
100	39.98	33.93	4.60	42.84	36.15	4.77	45.69	35.28	4.95	47.38	35.91	5.00	51.40	36.80	5.10	54.26	37.70	5.20
105	38.98	33.00	4.79	41.84	35.22	4.97	44.69	34.42	5.15	46.76	35.35	5.21	50.40	35.99	5.31	53.26	36.91	5.41
110	37.99	31.87	4.98	40.84	34.08	5.16	43.70	33.35	5.35	45.76	34.29	5.41	49.41	34.97	5.51	52.26	35.90	5.62
115	36.99	30.91	5.17	39.84	33.12	5.36	42.70	32.47	5.55	44.76	33.42	5.62	48.41	34.13	5.72	51.26	35.08	5.84
118	36.39	30.69	5.28	39.24	32.92	5.47	42.10	32.30	5.67	44.16	33.27	5.74	47.81	34.02	5.85	50.66	34.99	5.96
122	36.19	30.61	5.43	39.05	32.85	5.63	41.90	32.25	5.83	43.96	33.22	5.90	47.61	33.98	6.01	50.46	34.96	6.13

Product Data

- DB: Dry Bulb Temperature (°F) WB: Wet Bulb Temperature (°F) TC: Total Capacity (kBtu/h)  
 SHC: Sensible Capacity (kBtu/h) PI: Power Input (kW) (includes compressor, indoor fan motor and outdoor fan motor)
- All capacities are net, evaporator fan motor heat is deducted.
  - Cooling operating range with the Low Ambient Baffle Kit (sold separately) is -4°F to +122°F.
  - Grey shading indicates reference data. When operating the unit at this temperature, these values can be different by discontinuous operation.
  - Direct interpolation is permissible.  Do not extrapolate.

Nominal capacity as rated: 0 ft. above sea level with 25 ft. of refrigerant piping. 0 ft. level difference between outdoor and indoor units.  
 Nominal cooling capacity rating obtained with air entering the indoor unit at 80°F dry bulb (DB) and 67°F wet bulb (WB), and outdoor ambient conditions of 95°F dry bulb (DB) and 75°F wet bulb (WB).



# PERFORMANCE DATA

## Heating Capacity Tables

### Heating Capacity Table for LV181HV4 (LUU189HV + LVN181HV4)

Table 32: Heating Capacity Table for LUU189HV + LVN181HV4.

Outdoor Air Temp.		Indoor Air Temp. °F DB											
		61.0		64.0		68.0		70.0		72.0		75.0	
°F DB	°F WB	TC	PI	TC	PI	TC	PI	TC	PI	TC	PI	TC	PI
-4	-4.4	9.73	1.10	9.14	1.14	9.01	1.17	8.88	1.19	8.78	1.20	8.41	1.24
0	-0.4	10.79	1.14	10.22	1.18	10.02	1.21	9.87	1.23	9.75	1.25	9.34	1.29
5	4.5	11.96	1.19	11.42	1.23	11.14	1.27	10.96	1.29	10.81	1.31	10.38	1.34
10	9	12.96	1.24	12.44	1.28	12.09	1.32	11.89	1.34	11.72	1.36	11.26	1.40
17	15	14.16	1.30	13.67	1.35	13.24	1.39	13.00	1.41	12.81	1.43	12.32	1.47
20	19	14.92	1.35	14.45	1.39	13.97	1.43	13.71	1.46	13.50	1.47	12.99	1.52
25	23	16.20	1.39	15.72	1.43	15.17	1.48	14.89	1.50	14.66	1.52	14.11	1.57
30	28	17.49	1.44	16.95	1.49	16.37	1.53	16.07	1.56	15.83	1.58	15.24	1.63
35	32	18.78	1.48	18.18	1.53	17.56	1.58	17.24	1.60	16.99	1.63	16.38	1.67
40	36	19.73	1.52	19.18	1.57	18.57	1.62	18.25	1.65	17.99	1.67	17.34	1.72
45	41	20.93	1.57	20.43	1.63	19.83	1.68	19.50	1.71	19.24	1.73	18.54	1.78
47	43	21.41	1.60	20.93	1.65	20.33	1.70	<b>20.00</b>	<b>1.73</b>	19.73	1.75	19.02	1.81
50	46	21.47	1.59	21.04	1.63	20.52	1.68	20.22	1.71	19.98	1.73	19.31	1.77
55	51	21.58	1.57	21.22	1.61	20.83	1.65	20.59	1.66	20.40	1.68	19.79	1.71
60	56	21.68	1.55	21.40	1.58	21.14	1.61	20.95	1.62	20.81	1.63	20.28	1.66
63	59	21.74	1.54	21.51	1.57	21.32	1.59	21.18	1.60	21.06	1.60	20.57	1.62
68	64	21.81	1.53	21.62	1.55	21.51	1.57	21.40	1.57	21.31	1.58	20.86	1.59

DB: Dry Bulb Temperature (°F) WB: Wet Bulb Temperature (°F) TC: Total Capacity (kBtu/h)

PI: Power Input (kW) (includes compressor, indoor fan motor, and outdoor fan motor)

1. All capacities are net, evaporator fan motor heat is deducted.
2. Direct interpolation is permissible. ⚠ Do not extrapolate.

Nominal capacity as rated: 0 ft. above sea level with 25 ft. of refrigerant piping.

0 ft. level difference between outdoor and indoor units.

Nominal heating capacity rating obtained with air entering the indoor unit at 70°F dry bulb (DB) and 60°F wet bulb (WB), and outdoor ambient conditions of 47°F dry bulb (DB) and 43°F wet bulb (WB).

# PERFORMANCE DATA

## Heating Capacity Tables

### Heating Capacity Table for LV241HV4 (LUU249HV + LVN241HV4)

Table 33: Heating Capacity Table for LUU249HV + LVN241HV4.

Outdoor Air Temp.		Indoor Air Temp. °F DB											
		61.0		64.0		68.0		70.0		72.0		75.0	
°F DB	°F WB	TC	PI	TC	PI	TC	PI	TC	PI	TC	PI	TC	PI
-4	-4.4	15.61	1.65	14.71	1.70	14.46	1.75	14.26	1.78	14.09	1.80	13.50	1.85
0	-0.4	16.75	1.68	15.89	1.73	15.56	1.79	15.32	1.82	15.13	1.84	14.51	1.89
5	4.5	18.01	1.73	17.21	1.78	16.77	1.83	16.50	1.87	16.27	1.89	15.62	1.94
10	9	19.08	1.77	18.32	1.82	17.80	1.88	17.50	1.91	17.25	1.93	16.57	1.99
17	15	20.37	1.82	19.66	1.88	19.04	1.94	18.70	1.97	18.42	2.00	17.72	2.05
20	19	21.19	1.86	20.52	1.92	19.83	1.98	19.46	2.01	19.17	2.04	18.44	2.10
25	23	22.57	1.89	21.90	1.95	21.14	2.02	20.74	2.05	20.42	2.08	19.65	2.14
30	28	23.96	1.94	23.22	2.00	22.42	2.07	22.01	2.10	21.68	2.13	20.88	2.19
35	32	25.35	1.98	24.54	2.04	23.71	2.10	23.28	2.14	22.94	2.17	22.11	2.23
40	36	26.64	2.01	25.89	2.08	25.07	2.14	24.63	2.18	24.29	2.21	23.41	2.28
45	41	28.26	2.06	27.58	2.12	26.77	2.19	26.32	2.23	25.97	2.26	25.02	2.33
47	43	28.90	2.07	28.26	2.14	27.45	2.21	<b>27.00</b>	<b>2.25</b>	26.64	2.28	25.67	2.35
50	46	28.99	2.06	28.40	2.12	27.70	2.18	27.30	2.22	26.98	2.24	26.07	2.30
55	51	29.13	2.04	28.65	2.09	28.12	2.14	27.79	2.16	27.54	2.18	26.72	2.23
60	56	29.27	2.02	28.89	2.06	28.53	2.09	28.29	2.11	28.09	2.12	27.38	2.16
63	59	29.35	2.01	29.03	2.04	28.78	2.07	28.59	2.08	28.43	2.09	27.77	2.11
68	64	29.44	1.99	29.18	2.02	29.04	2.04	28.89	2.05	28.77	2.05	28.17	2.07

DB: Dry Bulb Temperature (°F) WB: Wet Bulb Temperature (°F) TC: Total Capacity (kBtu/h)

PI: Power Input (kW) (includes compressor, indoor fan motor, and outdoor fan motor)

1. All capacities are net, evaporator fan motor heat is deducted.

2. Direct interpolation is permissible. ⚠ Do not extrapolate.

Nominal capacity as rated: 0 ft. above sea level with 25 ft. of refrigerant piping.

0 ft. level difference between outdoor and indoor units.

Nominal heating capacity rating obtained with air entering the indoor unit at 70°F dry bulb (DB) and 60°F wet bulb (WB), and outdoor ambient conditions of 47°F dry bulb (DB) and 43°F wet bulb (WB).

# PERFORMANCE DATA

## Heating Capacity Tables

### Heating Capacity Table for LV361HV4 (LUU369HV + LVN361HV4)

Table 34: Heating Capacity Table for LUU369HV + LVN361HV4.

Outdoor Air Temp.		Indoor Air Temp. °F DB											
		61.0		64.0		68.0		70.0		72.0		75.0	
°F DB	°F WB	TC	PI	TC	PI	TC	PI	TC	PI	TC	PI	TC	PI
-4	-4.4	14.74	1.95	13.75	2.00	13.61	2.06	13.43	2.10	13.29	2.12	12.71	2.18
0	-0.4	17.41	2.06	16.45	2.12	16.15	2.19	15.91	2.22	15.72	2.25	15.07	2.31
5	4.5	20.38	2.20	19.43	2.27	18.96	2.34	18.66	2.37	18.41	2.40	17.67	2.47
10	9	22.90	2.33	21.98	2.40	21.36	2.47	20.99	2.51	20.70	2.55	19.89	2.62
17	15	25.93	2.50	25.03	2.58	24.24	2.66	23.80	2.70	23.45	2.74	22.55	2.82
20	19	27.85	2.61	26.97	2.69	26.07	2.78	25.58	2.82	25.19	2.86	24.24	2.95
25	23	31.07	2.72	30.15	2.81	29.10	2.90	28.55	2.95	28.11	2.99	27.05	3.08
30	28	34.31	2.87	33.25	2.96	32.11	3.05	31.52	3.10	31.05	3.15	29.91	3.24
35	32	37.55	2.98	36.36	3.08	35.12	3.17	34.49	3.23	33.98	3.27	32.76	3.37
40	36	39.47	3.09	38.36	3.19	37.14	3.30	36.49	3.35	35.98	3.40	34.68	3.50
45	41	41.86	3.24	40.86	3.34	39.66	3.45	39.00	3.51	38.47	3.56	37.07	3.66
47	43	42.82	3.29	41.86	3.40	40.66	3.51	<b>40.00</b>	<b>3.57</b>	39.47	3.62	38.03	3.73
50	46	42.94	3.27	42.08	3.37	41.04	3.47	40.44	3.52	39.97	3.56	38.62	3.66
55	51	43.15	3.24	42.44	3.32	41.65	3.40	41.18	3.43	40.79	3.46	39.59	3.54
60	56	43.36	3.20	42.80	3.26	42.27	3.32	41.91	3.35	41.62	3.37	40.56	3.42
63	59	43.49	3.18	43.01	3.23	42.64	3.28	42.35	3.30	42.12	3.31	41.14	3.35
68	64	43.61	3.16	43.23	3.20	43.02	3.24	42.80	3.25	42.62	3.25	41.73	3.28

DB: Dry Bulb Temperature (°F) WB: Wet Bulb Temperature (°F) TC: Total Capacity (kBtu/h)  
 PI: Power Input (kW) (includes compressor, indoor fan motor, and outdoor fan motor)  
 1. All capacities are net, evaporator fan motor heat is deducted.  
 2. Direct interpolation is permissible. ⊘ Do not extrapolate.  
 Nominal capacity as rated: 0 ft. above sea level with 25 ft. of refrigerant piping.  
 0 ft. level difference between outdoor and indoor units.

Nominal heating capacity rating obtained with air entering the indoor unit at 70°F dry bulb (DB) and 60°F wet bulb (WB), and outdoor ambient conditions of 47°F dry bulb (DB) and 43°F wet bulb (WB).



# PERFORMANCE DATA

## Heating Capacity Tables

### Heating Capacity Table for LV420HV (LUU428HV + LVN420HV)

Table 35: Heating Capacity Table for LUU428HV + LVN420HV.

Outdoor Air Temp.		Indoor Air Temp. °F DB											
		61.0		64.0		68.0		70.0		72.0		75.0	
°F DB	°F WB	TC	PI	TC	PI	TC	PI	TC	PI	TC	PI	TC	PI
-4	-4.4	20.39	2.80	18.93	2.91	18.79	2.95	18.57	2.97	18.38	2.98	17.57	3.09
0	-0.4	23.74	2.85	22.37	2.96	22.00	3.01	21.68	3.04	21.43	3.06	20.53	3.17
5	4.5	27.73	2.92	26.44	3.02	25.81	3.08	25.39	3.12	25.05	3.15	24.04	3.25
10	9	30.40	2.97	29.17	3.08	28.36	3.15	27.87	3.20	27.48	3.23	26.40	3.33
17	15	33.34	3.05	32.18	3.15	31.16	3.25	30.60	3.30	30.15	3.34	28.99	3.44
20	19	35.12	3.10	34.00	3.20	32.86	3.31	32.25	3.37	31.77	3.42	30.56	3.51
25	23	38.10	3.20	36.97	3.29	35.69	3.41	35.01	3.48	34.47	3.54	33.17	3.63
30	28	41.12	3.31	39.84	3.41	38.47	3.52	37.77	3.60	37.20	3.66	35.84	3.75
35	32	44.13	3.41	42.72	3.54	41.27	3.63	40.53	3.71	39.93	3.78	38.49	3.87
40	36	46.38	3.51	45.07	3.64	43.64	3.74	42.88	3.82	42.28	3.88	40.74	3.98
45	41	49.19	3.64	48.01	3.76	46.60	3.88	45.82	3.95	45.20	4.00	43.56	4.12
47	43	50.31	3.69	49.19	3.81	47.78	3.93	<b>47.00</b>	<b>4.00</b>	46.38	4.05	44.69	4.18
50	46	50.46	3.67	49.44	3.77	48.22	3.88	47.52	3.94	46.96	3.99	45.37	4.10
55	51	50.70	3.63	49.86	3.72	48.94	3.80	48.38	3.85	47.93	3.88	46.51	3.97
60	56	50.95	3.59	50.29	3.66	49.67	3.72	49.24	3.75	48.90	3.77	47.65	3.83
63	59	51.10	3.56	50.54	3.62	50.10	3.68	49.76	3.69	49.49	3.71	48.34	3.75
68	64	51.25	3.54	50.80	3.59	50.54	3.63	50.29	3.64	50.08	3.65	49.03	3.68

DB: Dry Bulb Temperature (°F) WB: Wet Bulb Temperature (°F) TC: Total Capacity (kBtu/h)

PI: Power Input (kW) (includes compressor, indoor fan motor, and outdoor fan motor)

1. All capacities are net, evaporator fan motor heat is deducted.

2. Direct interpolation is permissible. ⚠ Do not extrapolate.

Nominal capacity as rated: 0 ft. above sea level with 25 ft. of refrigerant piping.

0 ft. level difference between outdoor and indoor units.

Nominal heating capacity rating obtained with air entering the indoor unit at 70°F dry bulb (DB) and 60°F wet bulb (WB), and outdoor ambient conditions of 47°F dry bulb (DB) and 43°F wet bulb (WB).

# PERFORMANCE DATA

## Heating Capacity Tables

### Heating Capacity Table for LV480HV (LUU488HV + LVN480HV)

Table 36: Heating Capacity Table for LUU488HV + LVN480HV.

Outdoor Air Temp.		Indoor Air Temp. °F DB											
		61.0		64.0		68.0		70.0		72.0		75.0	
°F DB	°F WB	TC	PI	TC	PI	TC	PI	TC	PI	TC	PI	TC	PI
-4	-4.4	25.60	3.39	23.81	3.53	23.61	3.57	23.32	3.59	23.08	3.61	22.07	3.74
0	-0.4	29.41	3.47	27.72	3.61	27.25	3.66	26.86	3.69	26.55	3.72	25.43	3.85
5	4.5	33.94	3.57	32.37	3.70	31.59	3.78	31.08	3.82	30.67	3.86	29.43	3.99
10	9	36.97	3.67	35.48	3.79	34.49	3.89	33.90	3.94	33.42	3.98	32.11	4.11
17	15	40.31	3.79	38.91	3.91	37.68	4.03	37.00	4.10	36.45	4.15	35.05	4.27
20	19	42.33	3.87	40.98	3.99	39.62	4.13	38.88	4.21	38.29	4.27	36.84	4.38
25	23	45.72	4.02	44.37	4.14	42.83	4.29	42.02	4.38	41.37	4.45	39.81	4.57
30	28	49.15	4.19	47.63	4.33	45.99	4.46	45.15	4.56	44.48	4.64	42.84	4.75
35	32	52.58	4.35	50.90	4.51	49.17	4.62	48.29	4.73	47.58	4.82	45.86	4.94
40	36	55.26	4.48	53.70	4.64	51.99	4.77	51.09	4.87	50.37	4.95	48.55	5.08
45	41	58.60	4.64	57.20	4.79	55.52	4.94	54.60	5.03	53.86	5.11	51.90	5.25
47	43	59.94	4.70	58.60	4.86	56.93	5.01	<b>56.00</b>	<b>5.10</b>	55.26	5.17	53.25	5.32
50	46	60.12	4.67	58.91	4.81	57.45	4.95	56.62	5.03	55.95	5.09	54.06	5.22
55	51	60.41	4.62	59.41	4.74	58.31	4.85	57.65	4.91	57.11	4.95	55.42	5.06
60	56	60.71	4.57	59.92	4.66	59.18	4.75	58.67	4.78	58.27	4.81	56.78	4.89
63	59	60.88	4.54	60.22	4.62	59.70	4.69	59.29	4.71	58.96	4.73	57.59	4.79
68	64	61.06	4.52	60.52	4.57	60.22	4.63	59.91	4.64	59.67	4.65	58.42	4.69

DB: Dry Bulb Temperature (°F) WB: Wet Bulb Temperature (°F) TC: Total Capacity (kBtu/h)

PI: Power Input (kW) (includes compressor, indoor fan motor, and outdoor fan motor)

1. All capacities are net, evaporator fan motor heat is deducted.

2. Direct interpolation is permissible. Ⓣ Do not extrapolate.

Nominal capacity as rated: 0 ft. above sea level with 25 ft. of refrigerant piping.

0 ft. level difference between outdoor and indoor units.

Nominal heating capacity rating obtained with air entering the indoor unit at 70°F dry bulb (DB) and 60°F wet bulb (WB), and outdoor ambient conditions of 47°F dry bulb (DB) and 43°F wet bulb (WB).

# PERFORMANCE DATA

## Maximum Heating Capacity Tables

### Maximum Heating Capacity Table for LV181HV4 (LUU189HV + LVN181HV4)

Table 37: Maximum Heating Capacity Table for LUU189HV + LVN181HV4.

Outdoor Air Temp.		Indoor Air Temp. °F DB											
		61.0		64.0		68.0		70.0		72.0		75.0	
°F DB	°F WB	TC	PI	TC	PI	TC	PI	TC	PI	TC	PI	TC	PI
-13	-13.4	20.78	2.46	20.31	2.54	19.73	2.62	19.41	2.67	19.15	2.70	18.45	2.78
-4	-4.4	21.31	2.63	20.83	2.72	20.24	2.80	19.91	2.85	19.64	2.89	18.93	2.98
0	-0.4	21.59	2.73	21.11	2.82	20.51	2.91	20.17	2.96	19.90	3.00	19.18	3.09
5	4.5	21.94	2.86	21.45	2.95	20.84	3.05	20.50	3.10	20.23	3.14	19.49	3.24
10	9	22.17	2.62	21.68	2.70	21.06	2.79	20.71	2.84	20.44	2.88	19.70	2.96
17	15	22.48	2.44	21.98	2.52	21.35	2.61	21.00	2.65	20.72	2.69	19.97	2.77
20	19	22.94	2.41	22.43	2.49	21.78	2.57	21.43	2.61	21.14	2.65	20.37	2.72
25	23	23.40	2.37	22.87	2.45	22.22	2.53	21.86	2.57	21.57	2.60	20.78	2.68
30	28	23.97	2.32	23.43	2.40	22.76	2.48	22.39	2.52	22.10	2.55	21.29	2.63
35	32	24.43	2.29	23.88	2.36	23.20	2.44	22.82	2.48	22.52	2.51	21.70	2.59
40	36	24.89	2.25	24.33	2.32	23.64	2.40	23.25	2.44	22.94	2.47	22.11	2.55
45	41	25.46	2.20	24.89	2.28	24.18	2.35	23.79	2.39	23.47	2.42	22.62	2.50
47	43	25.69	2.19	25.12	2.26	24.40	2.33	<b>24.00</b>	<b>2.37</b>	23.68	2.40	22.82	2.47
50	46	25.77	2.17	25.25	2.24	24.62	2.30	24.26	2.34	23.98	2.36	23.17	2.43
55	51	25.89	2.15	25.46	2.20	24.99	2.25	24.71	2.28	24.48	2.30	23.75	2.35
60	56	26.02	2.13	25.68	2.17	25.36	2.21	25.15	2.22	24.97	2.24	24.33	2.27
63	59	26.09	2.11	25.81	2.15	25.59	2.18	25.41	2.19	25.27	2.20	24.68	2.22
68	64	26.17	2.10	25.94	2.13	25.81	2.15	25.68	2.16	25.57	2.16	25.04	2.18

DB: Dry Bulb Temperature (°F) WB: Wet Bulb Temperature (°F) TC: Total Capacity (kBtu/h)

PI: Power Input (kW) (includes compressor, indoor fan motor, and outdoor fan motor)

- All capacities are net, evaporator fan motor heat is deducted.
- Direct interpolation is permissible. ⚠ Do not extrapolate.
- Grey shading indicates reference data. When operating the unit at this temperature, these values can be different by discontinuous operation.

Nominal capacity as rated: 0 ft. above sea level with 25 ft. of refrigerant piping. 0 ft. level difference between outdoor and indoor units.

Nominal heating capacity rating obtained with air entering the indoor unit at 70°F dry bulb (DB) and 60°F wet bulb (WB), and outdoor ambient conditions of 47°F dry bulb (DB) and 43°F wet bulb (WB).

# PERFORMANCE DATA

## Maximum Heating Capacity Tables

### Maximum Heating Capacity Table for LV241HV4 (LUU249HV + LVN241HV4)

Table 38: Maximum Heating Capacity Table for LUU249HV + LVN241HV4.

Outdoor Air Temp.		Indoor Air Temp. °F DB											
		61		64		68		70		72		75	
°F DB	°F WB	TC	PI	TC	PI	TC	PI	TC	PI	TC	PI	TC	PI
-13	-13.4	19.66	2.61	19.22	2.70	18.67	2.78	18.36	2.83	18.12	2.87	17.46	2.95
-4	-4.4	22.22	2.79	21.73	2.88	21.11	2.98	20.76	3.03	20.49	3.07	19.74	3.16
0	-0.4	23.57	2.90	23.05	2.99	22.39	3.09	22.02	3.14	21.73	3.19	20.94	3.28
5	4.5	25.26	3.03	24.70	3.13	23.99	3.23	23.60	3.29	23.29	3.33	22.44	3.43
10	9	26.36	2.80	25.77	2.90	25.04	2.99	24.63	3.04	24.30	3.08	23.42	3.17
17	15	27.83	2.64	27.21	2.72	26.43	2.81	26.00	2.86	25.65	2.90	24.72	2.99
20	19	28.44	2.66	27.81	2.75	27.01	2.84	26.57	2.89	26.22	2.92	25.26	3.01
25	23	29.05	2.68	28.41	2.77	27.59	2.86	27.14	2.91	26.78	2.95	25.81	3.04
30	28	29.82	2.71	29.15	2.80	28.32	2.89	27.86	2.94	27.49	2.98	26.49	3.07
35	32	30.43	2.74	29.75	2.83	28.90	2.92	28.43	2.97	28.05	3.01	27.03	3.10
40	36	31.04	2.76	30.35	2.85	29.48	2.94	29.00	3.00	28.61	3.04	27.57	3.13
45	41	31.81	2.79	31.10	2.88	30.21	2.98	29.71	3.03	29.32	3.07	28.25	3.16
47	43	32.11	2.80	31.40	2.90	30.50	2.99	<b>30</b>	<b>3.04</b>	29.60	3.08	28.52	3.17
50	46	32.21	2.79	31.56	2.87	30.78	2.95	30.33	3.00	29.97	3.03	28.96	3.11
55	51	32.36	2.76	31.83	2.82	31.24	2.89	30.88	2.92	30.59	2.95	29.69	3.01
60	56	32.52	2.73	32.10	2.78	31.70	2.83	31.43	2.85	31.22	2.87	30.42	2.91
63	59	32.62	2.71	32.26	2.75	31.98	2.79	31.76	2.81	31.59	2.82	30.85	2.85
68	64	32.71	2.69	32.42	2.73	32.26	2.76	32.10	2.77	31.96	2.77	31.30	2.79

DB: Dry Bulb Temperature (°F) WB: Wet Bulb Temperature (°F) TC: Total Capacity (kBtu/h)

PI: Power Input (kW) (includes compressor, indoor fan motor, and outdoor fan motor)

- All capacities are net, evaporator fan motor heat is deducted.
- Direct interpolation is permissible. ⚠ Do not extrapolate.
- Grey shading indicates reference data. When operating the unit at this temperature, these values can be different by discontinuous operation.

Nominal capacity as rated: 0 ft. above sea level with 25 ft. of refrigerant piping. 0 ft. level difference between outdoor and indoor units.

Nominal heating capacity rating obtained with air entering the indoor unit at 70°F dry bulb (DB) and 60°F wet bulb (WB), and outdoor ambient conditions of 47°F dry bulb (DB) and 43°F wet bulb (WB).

# PERFORMANCE DATA

## Maximum Heating Capacity Tables

### Maximum Heating Capacity Table for LV361HV4 (LUU369HV + LVN361HV4)

Table 39: Maximum Heating Capacity Table for LUU369HV + LVN361HV4.

Outdoor Air Temp.		Indoor Air Temp. °F DB											
		61.0		64.0		68.0		70.0		72.0		75.0	
°F DB	°F WB	TC	PI	TC	PI	TC	PI	TC	PI	TC	PI	TC	PI
-13	-13.4	31.98	4.46	31.26	4.60	30.37	4.75	29.87	4.83	29.48	4.90	28.40	5.05
-4	-4.4	34.49	4.77	33.72	4.93	32.76	5.08	32.22	5.17	31.79	5.24	30.64	5.40
0	-0.4	35.81	4.95	35.01	5.12	34.01	5.28	33.46	5.37	33.01	5.44	31.81	5.61
5	4.5	37.47	5.18	36.63	5.35	35.58	5.52	35.00	5.62	34.53	5.70	33.28	5.87
10	9	38.54	5.10	37.68	5.27	36.61	5.43	36.01	5.53	35.53	5.60	34.24	5.77
17	15	39.98	5.03	39.09	5.20	37.97	5.37	37.35	5.46	36.85	5.53	35.51	5.70
20	19	40.84	4.90	39.93	5.06	38.79	5.22	38.16	5.31	37.65	5.38	36.28	5.54
25	23	41.71	4.76	40.78	4.91	39.61	5.07	38.96	5.16	38.45	5.23	37.05	5.38
30	28	42.79	4.58	41.83	4.73	40.64	4.88	39.97	4.97	39.44	5.04	38.01	5.19
35	32	43.65	4.44	42.68	4.59	41.46	4.73	40.78	4.82	40.24	4.88	38.78	5.03
40	36	44.52	4.30	43.52	4.44	42.28	4.59	41.59	4.67	41.03	4.73	39.54	4.87
45	41	45.60	4.13	44.58	4.26	43.30	4.40	42.60	4.48	42.03	4.54	40.50	4.67
47	43	46.03	4.06	45.00	4.19	43.71	4.33	<b>43.00</b>	<b>4.40</b>	42.43	4.46	40.89	4.59
50	46	46.16	4.03	45.23	4.15	44.11	4.27	43.47	4.34	42.96	4.39	41.51	4.51
55	51	46.39	3.99	45.62	4.09	44.78	4.18	44.26	4.23	43.85	4.27	42.55	4.36
60	56	46.61	3.95	46.01	4.02	45.44	4.10	45.05	4.13	44.74	4.15	43.60	4.22
63	59	46.75	3.92	46.24	3.98	45.84	4.04	45.53	4.06	45.28	4.08	44.22	4.13
68	64	46.89	3.90	46.47	3.95	46.24	3.99	46.01	4.00	45.82	4.01	44.86	4.04

DB: Dry Bulb Temperature (°F) WB: Wet Bulb Temperature (°F) TC: Total Capacity (kBtu/h)

PI: Power Input (kW) (includes compressor, indoor fan motor, and outdoor fan motor)

1. All capacities are net, evaporator fan motor heat is deducted.
2. Direct interpolation is permissible. ⚠ Do not extrapolate.
3. Grey shading indicates reference data. When operating the unit at this temperature, these values can be different by discontinuous operation.

Nominal capacity as rated: 0 ft. above sea level with 25 ft. of refrigerant piping. 0 ft. level difference between outdoor and indoor units.

Nominal heating capacity rating obtained with air entering the indoor unit at 70°F dry bulb (DB) and 60°F wet bulb (WB), and outdoor ambient conditions of 47°F dry bulb (DB) and 43°F wet bulb (WB).

# PERFORMANCE DATA

## Maximum Heating Capacity Tables

### Maximum Heating Capacity Table for LV420HV (LUU428HV + LVN420HV)

Table 40: Maximum Heating Capacity Table for LUU428HV + LVN420HV.

Outdoor Air Temp.		Indoor Air Temp. °F DB											
		61.0		64.0		68.0		70.0		72.0		75.0	
°F DB	°F WB	TC	PI	TC	PI	TC	PI	TC	PI	TC	PI	TC	PI
-4	-4.4	25.69	4.33	25.12	4.48	24.40	4.62	24.00	4.70	23.68	4.76	22.82	4.91
0	-0.4	29.50	4.37	28.84	4.52	28.01	4.66	27.56	4.74	27.19	4.81	26.20	4.95
5	4.5	34.25	4.43	33.49	4.57	32.53	4.72	32.00	4.80	31.57	4.87	30.43	5.01
10	9	36.55	4.53	35.73	4.68	34.71	4.83	34.14	4.92	33.69	4.98	32.46	5.13
17	15	40.31	4.62	38.91	4.77	37.68	4.92	37.00	5.00	36.45	5.07	35.05	5.21
20	19	42.18	4.64	40.83	4.78	39.47	4.95	38.74	5.04	38.15	5.11	36.70	5.26
25	23	45.31	4.69	43.96	4.82	42.44	5.01	41.63	5.11	40.99	5.19	39.45	5.33
30	28	48.47	4.76	46.97	4.91	45.36	5.06	44.53	5.18	43.86	5.26	42.25	5.40
35	32	51.64	4.82	49.99	4.99	48.29	5.12	47.42	5.24	46.73	5.34	45.04	5.47
40	36	54.27	4.96	52.74	5.14	51.06	5.28	50.18	5.39	49.47	5.48	47.68	5.62
45	41	57.56	5.14	56.18	5.31	54.53	5.48	53.62	5.58	52.90	5.66	50.98	5.82
47	43	58.87	5.21	57.56	5.38	55.91	5.55	<b>55.00</b>	<b>5.65</b>	54.27	5.73	52.30	5.90
50	46	59.05	5.18	57.86	5.33	56.42	5.49	55.61	5.57	54.95	5.64	53.10	5.79
55	51	59.33	5.12	58.35	5.25	57.27	5.37	56.62	5.43	56.09	5.48	54.43	5.60
60	56	59.62	5.07	58.85	5.17	58.12	5.26	57.63	5.30	57.23	5.33	55.76	5.41
63	59	59.80	5.03	59.14	5.12	58.63	5.19	58.23	5.22	57.91	5.24	56.56	5.30
68	64	59.97	5.00	59.44	5.07	59.15	5.13	58.84	5.14	58.60	5.15	57.38	5.19

DB: Dry Bulb Temperature (°F) WB: Wet Bulb Temperature (°F) TC: Total Capacity (kBtu/h)

PI: Power Input (kW) (includes compressor, indoor fan motor, and outdoor fan motor)

1. All capacities are net, evaporator fan motor heat is deducted.
2. Direct interpolation is permissible.  Do not extrapolate.

Nominal capacity as rated: 0 ft. above sea level with 25 ft. of refrigerant piping. 0 ft. level difference between outdoor and indoor units.

Nominal heating capacity rating obtained with air entering the indoor unit at 70°F dry bulb (DB) and 60°F wet bulb (WB), and outdoor ambient conditions of 47°F dry bulb (DB) and 43°F wet bulb (WB).

# PERFORMANCE DATA

## Maximum Heating Capacity Tables

### Maximum Heating Capacity Table for LV480HV (LUU488HV + LVN480HV)

Table 41: Maximum Heating Capacity Table for LUU488HV + LVN480HV.

Outdoor Air Temp.		Indoor Air Temp. °F DB											
		61.0		64.0		68.0		70.0		72.0		75.0	
°F DB	°F WB	TC	PI	TC	PI	TC	PI	TC	PI	TC	PI	TC	PI
-4	-4.4	27.83	4.71	27.21	4.86	26.43	5.02	26.00	5.10	25.65	5.17	24.72	5.33
0	-0.4	31.64	4.77	30.93	4.92	30.05	5.08	29.56	5.17	29.16	5.24	28.10	5.40
5	4.5	36.39	4.84	35.58	5.00	34.56	5.16	34.00	5.25	33.55	5.32	32.33	5.48
10	9	39.15	4.92	38.27	5.08	37.18	5.25	36.57	5.34	36.09	5.41	34.77	5.57
17	15	43.58	4.99	42.06	5.15	40.74	5.31	40.00	5.40	39.41	5.47	37.89	5.63
20	19	45.68	5.00	44.23	5.15	42.75	5.33	41.96	5.43	41.32	5.51	39.75	5.66
25	23	49.21	5.02	47.75	5.17	46.09	5.37	45.22	5.47	44.52	5.56	42.84	5.71
30	28	52.77	5.07	51.14	5.24	49.38	5.40	48.47	5.52	47.75	5.62	45.99	5.76
35	32	56.33	5.12	54.54	5.30	52.68	5.44	51.73	5.57	50.98	5.67	49.13	5.81
40	36	59.20	5.27	57.54	5.45	55.70	5.61	54.74	5.73	53.97	5.82	52.01	5.97
45	41	62.79	5.46	61.29	5.64	59.48	5.82	58.50	5.92	57.71	6.01	55.61	6.18
47	43	64.23	5.53	62.79	5.72	61.00	5.90	<b>60.00</b>	<b>6.00</b>	59.20	6.08	57.05	6.26
50	46	64.41	5.50	63.12	5.66	61.55	5.83	60.66	5.91	59.95	5.98	57.92	6.15
55	51	64.73	5.44	63.66	5.57	62.48	5.71	61.76	5.77	61.19	5.82	59.38	5.95
60	56	65.04	5.38	64.20	5.49	63.41	5.59	62.86	5.63	62.43	5.66	60.83	5.75
63	59	65.23	5.35	64.52	5.43	63.96	5.51	63.53	5.54	63.18	5.56	61.71	5.63
68	64	65.42	5.31	64.85	5.38	64.52	5.44	64.19	5.46	63.93	5.47	62.59	5.51

DB: Dry Bulb Temperature (°F) WB: Wet Bulb Temperature (°F) TC: Total Capacity (kBtu/h)

PI: Power Input (kW) (includes compressor, indoor fan motor, and outdoor fan motor)

1. All capacities are net, evaporator fan motor heat is deducted.
2. Direct interpolation is permissible.  Do not extrapolate.

Nominal capacity as rated: 0 ft. above sea level with 25 ft. of refrigerant piping. 0 ft. level difference between outdoor and indoor units.

Nominal heating capacity rating obtained with air entering the indoor unit at 70°F dry bulb (DB) and 60°F wet bulb (WB), and outdoor ambient conditions of 47°F dry bulb (DB) and 43°F wet bulb (WB).

# EQUIPMENT SELECTION PROCEDURE

## Correction Factors

### Cooling / Heating Correction Factors

For Single Zone Vertical Air Handling Unit systems, calculate the equivalent length of the liquid line from the outdoor unit to the indoor unit. Also, determine the elevation difference of the indoor unit above or below the outdoor unit. Find corresponding cooling or heating capacity correction factors as shown below. Multiply the correction factors by the cooling or heating capacity obtained from the capacity table using design conditions. The result is the NET cooling or heating capacity.

### Refrigerant Line Length Derates

For air-cooled systems, a capacity correction factor may have to be applied to account for the length of the system's refrigerant pipe. Rate of change in capacity due to increased piping lengths is shown below.

### Cooling Capacity Coefficient Factors

Table 42: Vertical Air Handling Unit Cooling Capacity Coefficient Factors.

Piping Length (ft.)		24.6	32.8	49.2	65.6	98.4	131.2	164	196.9	229.7	246
Rate of Capacity Change (%)	LUU189HV (18,000 Btu/h)	100	100	99.3	97.9	96.6	93.8	91.1	-	-	-
	LUU249HV (24,000 Btu/h)	100	100	99.3	97.9	96.6	93.8	91.1	-	-	-
	LUU369HV (36,000 Btu/h)	100	100	99.3	97.9	96.6	93.8	91.1	88.4	85.6	82.9
	LUU428HV (42,000 Btu/h)	100	99.3	97.9	96.6	93.8	91.1	88.4	85.6	82.9	81.5
	LUU488HV (48,000 Btu/h)	100	99.3	97.9	96.6	93.8	91.1	88.4	85.6	82.9	81.5

### Heating Capacity Coefficient Factors

Table 43: Vertical Air Handling Unit Heating Capacity Coefficient Factors.

Piping Length (ft.)		24.6	32.8	49.2	65.6	98.4	131.2	164	196.9	229.7	246
Rate of Capacity Change (%)	LUU189HV (18,000 Btu/h)	100	99.3	97.9	96.6	94.8	91.1	88.4	-	-	-
	LUU249HV (24,000 Btu/h)	100	99.3	97.9	96.6	94.8	91.1	88.4	-	-	-
	LUU369HV (36,000 Btu/h)	100	99.7	99.2	98.7	97.7	96.6	95.6	94.6	93.5	93.0
	LUU428HV (42,000 Btu/h)	100	99.7	99.2	98.7	97.7	96.6	95.6	94.6	93.5	93.0
	LUU488HV (48,000 Btu/h)	100	99.7	99.2	98.7	97.7	96.6	95.6	94.6	93.5	93.0



# EQUIPMENT SELECTION PROCEDURE

## Correction Factors

### Equivalent Piping Length for Piping Components

Table 44: Equivalent Piping Length for Elbows.

Component	Size (Inches)													
	1/4	3/8	1/2	5/8	3/4	7/8	1	1-1/8	1-1/4	1-3/8	1-1/2	1-5/8	1-3/4	2-1/8
Elbow (ft.)	0.5	0.6	0.7	0.8	1.2	1.3	1.5	1.6	1.8	2.0	2.1	2.3	2.5	2.8

### Altitude Correction Factor

The impact of air density must be considered on systems installed at a significant altitude above sea level, therefore, locally accepted altitude correction factors must be applied.

### Defrost Correction Factor for Heating Operation

The outdoor unit heating capacity may need to be adjusted for frost accumulation on air-cooled systems. If design day conditions are below the dewpoint of the surrounding air, frost may not be a problem and no correction factor is needed. In certain weather conditions, however, frost may form and accumulate on the air-cooled outdoor unit coil and impact the coils ability to transfer heat. If significant frost accumulates on the outdoor unit coil, a defrost algorithm will start automatically. The timing between defrost periods is determined by the system's ability to achieve a target head pressure value.

Capacity and AHRI ratings tables do not factor in capacity reduction when frost has accumulated on the condenser coil, nor during defrost operation.

Integrated heating capacity values can be obtained using the formula: Table 45: Outdoor Unit Frost Accumulation Factor (Heating)<sup>1</sup>.

$$A = B \times C$$

Where:

A = Integrated Heating Capacity.

B = Value found in the Capacity Table.

C = Correction Factor for Frost Accumulation Factor (from table at right).

Entering DB (°F)	19.4	23.0	26.6	32.0	37.4	41.0	44.6
Derate factor	0.98	0.95	0.93	0.86	0.93	0.96	1.0

<sup>1</sup>At 85% outdoor air relative humidity.

The frost accumulation factor does not account for effects of snow accumulation restricting airflow through the outdoor unit coil.

### Note:

There will be a temporary reduction in capacity when frost / ice accumulates on the outside surface of the outdoor unit heat exchanger. The level of capacity reduction depends on a number of factors, for example, outdoor temperature (°F DB), relative humidity (RH), and the amount of frost present.

# EQUIPMENT SELECTION PROCEDURE

## Check the Indoor and Outdoor Unit Selection(s)

Compare the corrected cooling and heating capacities to the load calculations. Is each capacity sufficient for the zone it serves?

For each indoor unit, the corrected capacity must be at least equal to the total of the cooling design load (plus ventilation load, if applicable) for the space served by the indoor unit. For each indoor unit, the corrected capacity also must be at least equal to the total of the heating design load (plus ventilation load, if applicable) for the space(s) and / or thermal zones served by the indoor unit.

The outdoor unit selected must be large enough to offset the total cooling load for all spaces it serves (account for ventilation air cooling load if the ventilation air has not been pretreated to room neutral conditions). The outdoor unit must also be large enough to offset the total heating load for all spaces it serves.

If the corrected heating capacity ratio exceeds 100%, reselect the equipment, or change the system design by moving some of the load to another system.

## System Sizing Check Formulas

### 1. Outdoor Unit Rated Capacity.

$Q_{\text{odu(rated)}}$  (From capacity tables).

### 2. Outdoor Unit Capacity at $T_i$ , $T_o$ Temperature.

$Q_{\text{odu}(T_i, T_o)}$  (From capacity tables).

### 3. Outdoor Unit Capacity Coefficient Factor.

$F_{(T_i, T_o)} = Q_{\text{odu}(T_i, T_o)} / Q_{\text{odu(rated)}}$

### 4. Piping Correction Factor (From Capacity Coefficient Factor Tables).

$F_{(\text{length})}$  for each piping length

### 5. Individual Indoor Unit Combination Capacity.

$Q_{\text{idu (combi)}} = Q_{\text{odu(rated)}} \times Q_{\text{idu(rated)}} / Q_{\text{idu(rated-total)}}$

### 6. Individual Indoor Unit Actual Capacity.

$Q_{\text{idu (actual)}} = Q_{\text{idu(combi)}} \times F_{(T_i, T_o)} \times F_{(\text{length, altitude})}$

## Conclusions and Recommendations

- Understand the design safety factors.
- Reference load calculations for actual cooling and heating capacities (applies in 99% of applications – consider total load when latent load is greater than 30%).
- Verify that the sensible load of the zone is satisfied.
- Use caution when sizing to meet listed capacity specifications for the scheduled manufacturer's equipment.

If further system design assistance is needed, or you have a unique application you would like to discuss, contact your LG sales rep.

# VERTICAL AIR HANDLING UNIT APPLICATION GUIDELINES

**Placement Considerations on page 76**

**Clearances on page 80**

**Installing Outdoor Units Indoors on page 83**

**Refrigerant Piping Design on page 85**

# PLACEMENT CONSIDERATIONS

## Indoor Unit

### Selecting the Best Location for the Indoor Unit

#### Do's

- Place the unit where air circulation will not be blocked.
- Place the unit where drainage can be obtained easily and to minimize the length of the condensate drain piping.
- Place the unit where noise prevention is taken into consideration.
- Place the unit in a location that can support the indoor unit weight, and where the indoor unit can be level.
- The mounting floor must be strong and solid enough to prevent the indoor unit from vibrating.
- Ensure there is sufficient maintenance and clearance space (wall, ceiling, or other obstacles; see diagram for clearances).
- Locate the indoor unit in a location where it can be easily connected to the outdoor unit.



#### Don'ts

- Avoid installing the unit near high-frequency generators.
- No obstacles must be present to prevent indoor unit air circulation.
- Do not install the unit near a doorway.
- Do not install the unit near a heat or steam source, or where considerable amounts of oil, iron powder, or flour are used. (These materials may generate condensate, cause a reduction in heat exchanger efficiency, or the drain pump to malfunction. If this is a potential problem, install a ventilation fan large enough to vent out these materials.)

### WARNING

The unit must not be installed where sulfuric acid and flammable or corrosive gases are generated, vented into, or stored. There is risk of fire, explosion, and physical injury or death.

The unit may be damaged, may malfunction, and / or will not operate as designed if installed in any of the conditions listed.

### Note:

- ⊘ Indoor units (IDUs) must not be placed in an environment where the IDUs may be exposed to harmful volatile organic compounds (VOCs) or in environments where there is improper air make up or supply or inadequate ventilation. If there are concerns about VOCs in the environment where the IDUs are installed, proper air make up or supply and/ or adequate ventilation must be provided. Additionally, in buildings where IDUs will be exposed to VOCs, consider a factory-applied epoxy coating to the fan coils for each IDU.

If the unit is installed near a body of water, the installation parts are at risk of corroding. Appropriate anti-corrosion methods must be taken for the unit and all installation parts.

### Installing in an Area Exposed to Unconditioned Air

In some installation applications, areas (floors, walls) in some rooms may be exposed to unconditioned air (room may be above or next to an unheated garage or storeroom). To countermeasure:

- Verify that carpet is or will be installed (carpet may increase the temperature by three [3] degrees).
- Add insulation between the floor joists.
- Install radiant heat or another type of heating system to the floor.

Figure 50: Recommended Clearances for Vertical Air Handling Unit IDU.

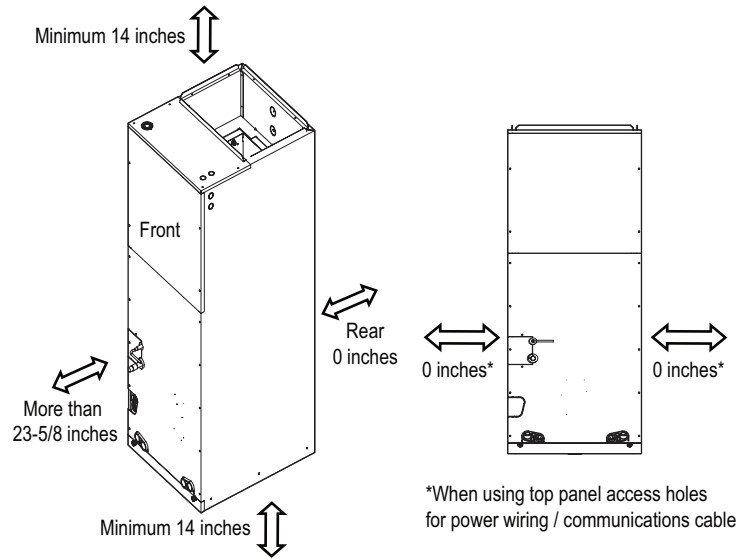
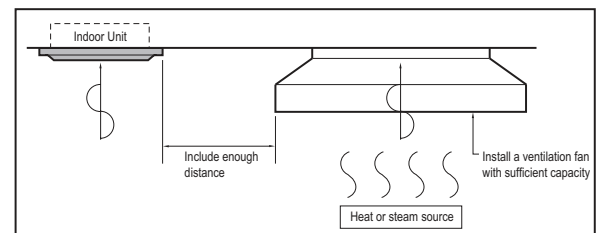

Figure 51: Installing Near a Heat or Steam Source.



# PLACEMENT CONSIDERATIONS

## Outdoor Unit

### Selecting the Best Location for the Outdoor Unit

#### **⚠ DANGER**

- ⊘ Do not install the unit in an area where combustible gas may generate, flow, stagnate, or leak. These conditions can cause a fire, resulting in bodily injury or death.
- ⊘ Do not install the unit in a location where acidic solution and spray (sulfur) are often used as it can cause bodily injury or death.
- ⊘ Do not use the unit in environments where oil, steam, or sulfuric gas are present as it can cause bodily injury or death.

#### **⚠ WARNING**

When deciding on a location to place the outdoor unit, be sure to choose an area where run-off from defrost will not accumulate and freeze on sidewalks or driveways, which may create unsafe conditions. Properly install and insulate any drain hoses to prevent the hose from freezing, cracking, leaking, and causing unsafe conditions from frozen condensate.

Install a fence to prevent vermin from crawling into the unit or unauthorized individuals from accessing it. Follow the placement guidelines set forth in "Clearance Requirements".

Select a location for installing the outdoor unit that will meet the following conditions:

- Where there is enough strength to bear the weight of the outdoor unit.
- A location that allows for optimum air flow and is easily accessible for inspection, maintenance, and service.
- Where piping between the outdoor unit and indoor unit(s) are within allowable limits.
- Include space for drainage to ensure condensate flows properly out of the unit when it is in heating mode. Avoid placing the outdoor unit in a low-lying area where water could accumulate.
- If the outdoor unit is installed in a highly humid environment (near an ocean, lake, etc.), ensure that the site is well-ventilated and has a lot of natural light (Example: Install on a rooftop).



#### **Don'ts**

- Where it will be subjected to direct thermal radiation from other heat sources, or an area that would expose the outdoor unit to heat or steam like discharge from boiler stacks, chimneys, steam relief ports, other air conditioning units, kitchen vents, plumbing vents, and other sources of extreme temperatures.
- Where high-frequency electrical noise / electromagnetic waves will not affect operation.
- Where operating sound from the unit will disturb inhabitants of surrounding buildings.
- Where the unit will be exposed to direct, strong winds.
- Where the discharge of one outdoor unit will blow into the inlet side of an adjacent unit (when installing multiple outdoor units).

#### **Note:**

The indoor unit may take longer to provide heat, or heating performance will be reduced in winter if the unit is installed:

1. In a narrow, shady location.
2. Near a location that has a lot of ground moisture.
3. In a highly humid environment.
4. In an area in which condensate does not drain properly.

# PLACEMENT CONSIDERATIONS

## Outdoor Unit

### Planning for Snow and Ice

To ensure the outdoor unit operates properly, certain measures are required in locations where there is a possibility of heavy snowfall or severe windchill or cold:

1. Prepare for severe winter wind chills and heavy snowfall, even in areas of the country where these are unusual phenomena.
2. Position the outdoor unit so that its airflow fans are not buried by direct, heavy snowfall. If snow piles up and blocks the airflow, the system may malfunction.
3. Remove any snow that has accumulated four (4) inches or more on the top of the outdoor unit.
4. In climates that may experience significant snow buildup, mount the outdoor unit on a raised, field-provided platform or stand. The raised support platform must be high enough to allow the unit to remain above possible snow drifts, and must be higher than the maximum anticipated snowfall for the location.
5. Design the mounting base to prevent snow accumulation on the platform in front or back of the unit frame.
6. Provide a field fabricated snow protection hood to keep snow and ice and/or drifting snow from accumulating on the coil surfaces.
7. Install a hail guard kit and air guide accessories (sold separately) to prevent snow or rain from accumulating on the fan inlet / outlet guards.
8. Consider tie-down requirements in case of high winds or where required by local codes.

### ⚠ CAUTION

When deciding on a location to place the outdoor unit, be sure to choose an area where run-off from defrost will not accumulate and freeze on sidewalks or driveways, which may create unsafe conditions.

### Note:

Choose an area where run-off from defrost mode will not accumulate and freeze on sidewalks or driveways. Properly install and insulate any drain hoses to prevent the hose from freezing, cracking, leaking, and damaging the outdoor unit.

## Tie-Downs, Wind Restraints, and Lightning Protection

### Tie-Downs

- The strength of the roof must be checked before installing the outdoor units.
- If the installation site is prone to high winds or earthquakes, when installing on the wall or roof, securely anchor the mounting base using a field-provided tie-down configuration approved by a local professional engineer.
- The overall tie-down configuration must be approved by a local professional engineer. Always refer to local code when using a wind restraint system.

### Note:

Always refer to local code when designing a wind restraint system.

### Lightning Protection

- To protect the outdoor unit from lightning, place the unit within the specified lightning safety zone.

Table 46: Safety Zone Specifications.

Building Height (feet)	66	98	148	197
Protection Angle (°)	55	45	35	25

- Power cable and communication cable must be installed five (5) feet away from lightning rod.
- A high-resistance ground system must be included to protect against induced lightning or indirect strike.

Figure 52: Lightning Protection Diagram.

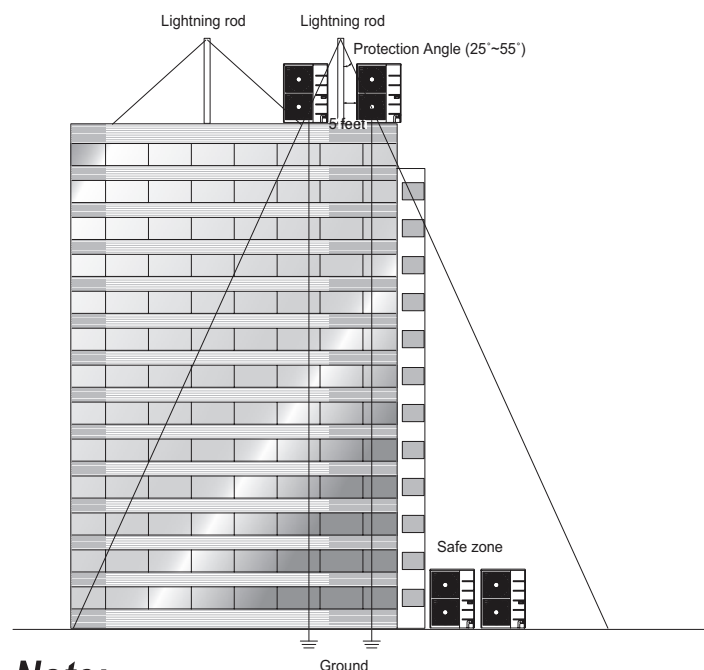

### Note:

If the building does not include lightning protection, the outdoor unit may be damaged from a lightning strike. Inform the customer of this possibility in advance.

# PLACEMENT CONSIDERATIONS

## Outdoor Unit

### Wind Protection

If the outdoor unit is placed on a roof, position it with the compressor end (no coil surface) in the direction of the prevailing wind as shown in the figure at right. In cooler climates, it may be beneficial to position the unit in direct sunlight to assist with defrost operations.

If the outdoor unit is not placed on a roof, place it on the leeward side of the building or in a location where the unit will not be exposed to constant wind.

If placement exposes the unit to constant wind activity, construct a wind break in front of the unit. Follow the placement guidelines set forth in "Clearance Requirements".

### Tie-Downs and Wind Restraints

The strength of the Vertical Air Handling Unit frames is adequate to be used with field-provided wind restraint tie-downs. The overall tie-down configuration must be approved by a local professional engineer. Always refer to local code when designing a wind restraint system.

### Mounting Platform

The underlying structure or foundation must be designed to support the weight of the unit. Avoid placing the unit in a low lying area where water may accumulate.

### Oceanside Installation Precautions

#### Note:

*Ocean winds may cause corrosion, particularly on the condenser and evaporator fins, which, in turn could cause product malfunction or inefficient performance.*

- Avoid installing the outdoor unit where it would be directly exposed to ocean winds.
- Install the outdoor unit on the side of the building opposite from direct ocean winds.
- Select a location with good drainage.
- Periodically clean dust or salt particles off of the heat exchanger with water.

If the outdoor unit must be placed in a location where it would be subjected to direct ocean winds, install a concrete windbreaker strong enough to block any winds. Windbreaker height and width must be more than 150% of the outdoor unit, and be installed at least 27-1/2 inches away from the outdoor unit to allow for airflow.

Figure 53: Prevailing Wind Direction.

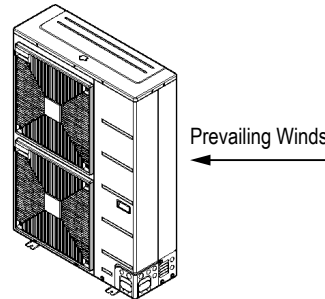

Figure 54: Leeward Side of the Building.



Figure 55: Wind Break.

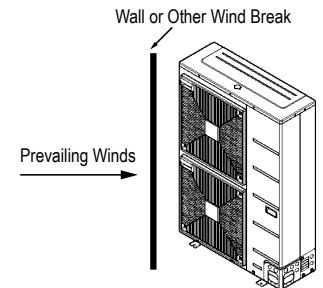
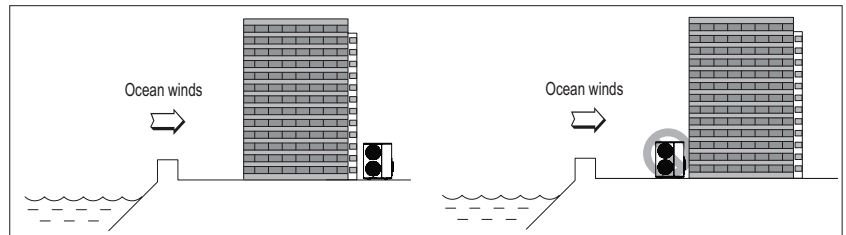
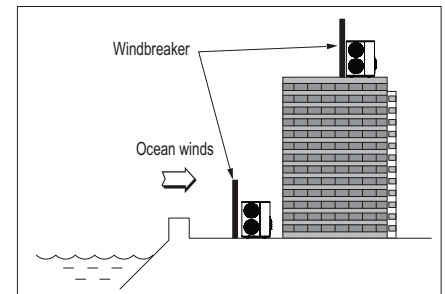

Figure 56: Oceanside Placement Using a Building as Shield, and Placement Using a Windbreaker.



#### Note:

*Additional anti-corrosion treatment may need to be applied to the outdoor unit at oceanside locations.*



# CLEARANCES

## Outdoor Unit

### Minimum Clearance Requirements for Vertical Air Handling Unit ODUs

Proper clearance for the outdoor unit coil is critical for proper unit operation. When installing the outdoor unit, consider service, inlet and outlet and minimum allowable space requirements as illustrated in the diagrams below and on the next few pages.

#### Minimum Clearance Requirements for LUU189HV, LUU249HV Outdoor Units

Specific clearance requirements in the diagram below are for 18,000 Btu/h (LUU189HV), and 24,000 Btu/h (LUU249HV) systems. The following figure shows the overall minimum clearances that must be observed for safe operation and adequate airflow around the outdoor unit. When placing the outdoor unit under an overhang, awning, sunroof or other “roof-like structure”, observe the clearance requirements (as shown in Cases 1 and 2 for height in relation to the unit. This clearance ensures that heat radiation from the condenser is not restricted around the unit.

Adhere to all clearance requirements if installing the unit on a roof. Be sure to level the unit and ensure that the unit is adequately anchored. Consult local codes for rooftop mounting requirements.

To have successful service access to the outdoor unit, see the following figure for minimum spacing. When installing multiple outdoor units, see Cases 4 and 5 for correct spacing requirements.

#### Note:

If the outdoor unit is installed between standard and minimum clearances, capacity decreases approximately 10%.

Figure 57: Outdoor Unit Service Access and Allowable Clearances Diagram.

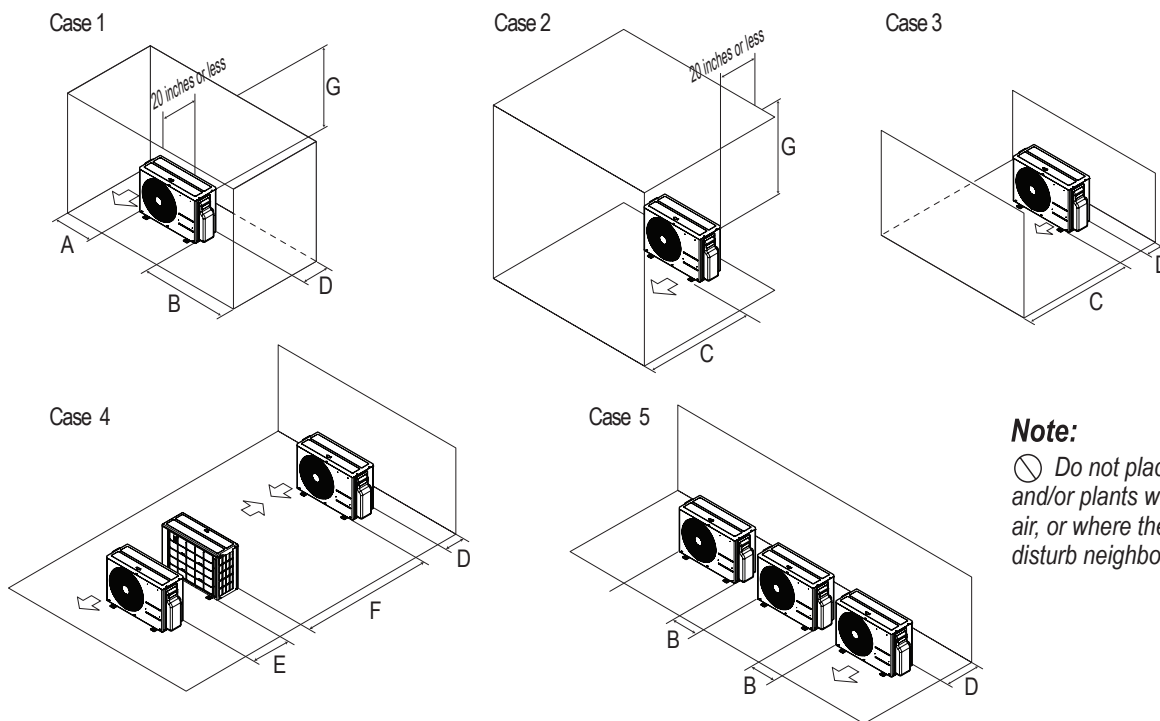

#### Note:

⊘ Do not place the unit where animals and/or plants will be in the path of the warm air, or where the warm air and / or noise will disturb neighbors.

Table 47: 24K Outdoor Unit Service Access and Allowable Clearances Diagram Legend.

Unit: Inch		A	B	C	D	E	F	G
Case 1	Standard	12	24	-	12	-	-	-
	Minimum	4	10	-	4	-	-	40
Case 2	Standard	-	-	20	-	-	-	-
	Minimum	-	-	14	-	-	-	40
Case 3	Standard	-	-	20	12	-	-	-
	Minimum	-	-	14	4	-	-	-
Case 4	Standard	-	-	-	12	24	-	-
	Minimum	-	-	-	4	8	79	-
Case 5	Standard	-	24	-	12	-	-	-
	Minimum	-	10	-	4	-	-	-



# CLEARANCES

## Outdoor Unit

### Minimum Clearance Requirements for LUU369HV, LUU428HV, LUU488HV Outdoor Units

Figures below and on the next page illustrate clearance requirements for various installation scenarios for 38,000 Btu/h (LUU369HV), 42,000 Btu/h (LUU428HV), and 48,000 Btu/h (LUU488HV) outdoor units. Use the hot isle / cold isle approach when placing multiple units in close proximity to each other. Outdoor unit fans draw air from the back of the unit and discharges out the front. Place units back to back and face to face.

#### Note:

- Installation clearances must comply with local building codes.
- All figures not to scale.
-  Never place multiple units facing back to front or front to back as shown immediately below here or high and low system pressure problems may occur.

#### Legend

- LR = Rear wall height
- LF = Front wall height
- H = Unit height

Figure 58: Improper Outdoor Unit Placement.

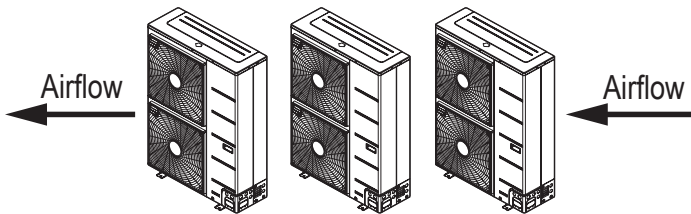

Figure 59: Proper Outdoor Unit Placement and Clearances.

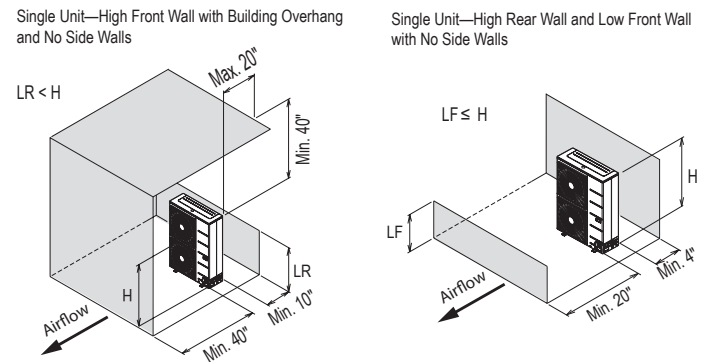
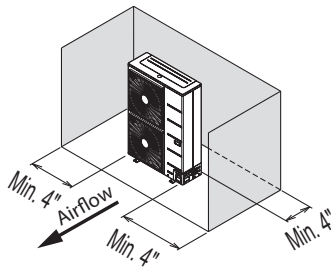
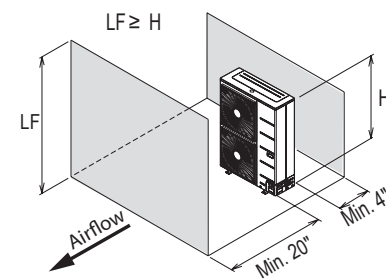

Figure 60: Proper Outdoor Unit Placement and Clearances, continued.

Single Unit—High Rear Wall with or without High Side Walls



Single Unit—High Rear and Front Walls with No Side Walls



Side by Side—High Rear and Side Walls

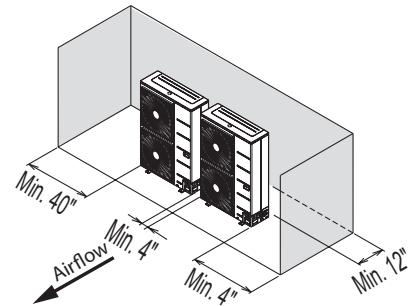

Single Unit—High Rear and Side Walls with Building Overhang

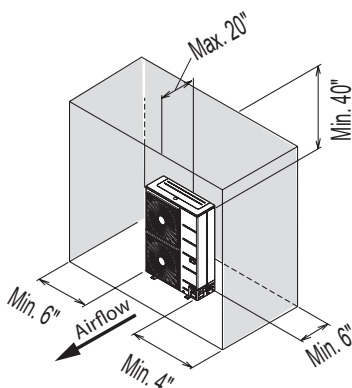

Single Unit—High Front and Rear Walls with Building Overhang and No Side Walls

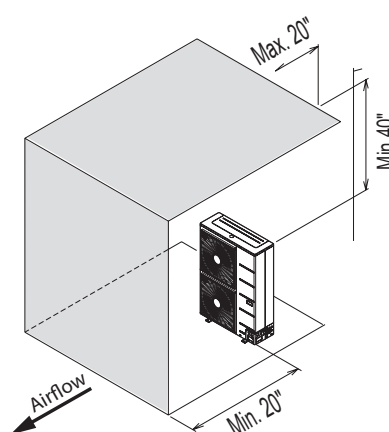

Single Unit—High Rear Wall and Low Front Wall with Building Overhang and No Side Walls

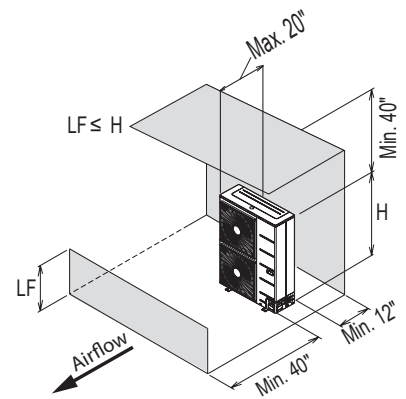

# CLEARANCES

## Outdoor Unit

### Note:

- Installation clearances must comply with local building codes.
- All figures not to scale.

### Legend

LR = Rear wall height

LF = Front wall height

H = Unit height

Figure 62: Proper Outdoor Unit Placement and Clearances, continued.

Single Row Units—High Rear Wall and Low Front Wall with No Side Walls or Overhang

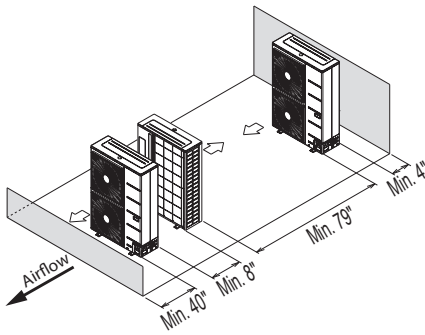

Side by Side—High Front Wall with Building Overhang and No Side or Rear Walls

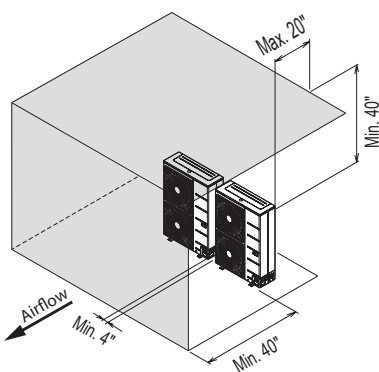

Side by Side—High Rear Wall and Low Front Wall with No Side Walls

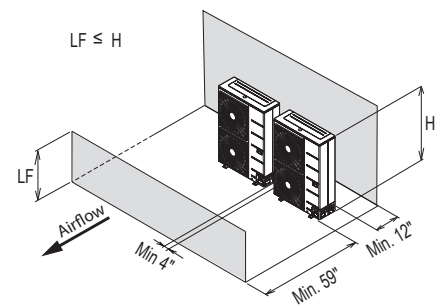

Double Row Units—Low Rear and Front Walls with No Side Walls or Overhang

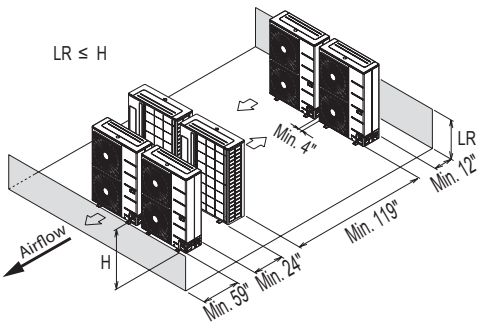

Side by Side—High Front and Rear Walls with No Side Walls

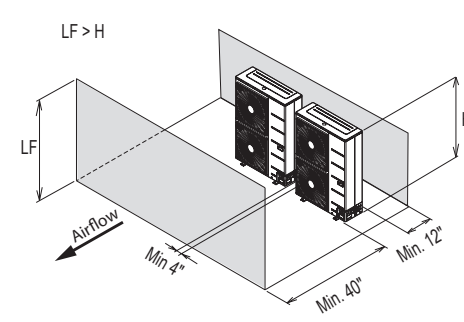

Side by Side—High Rear Wall and Low Front Wall with Building Overhang and No Side Walls

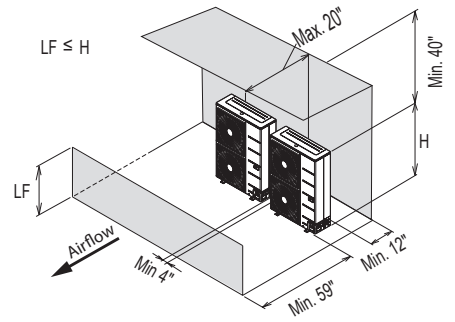
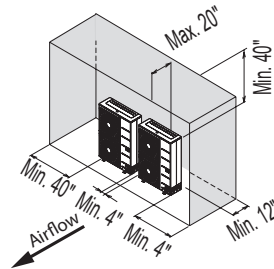
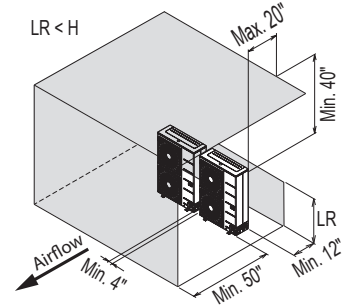

Figure 61: Proper Outdoor Unit Placement and Clearances, continued.

Side by Side—High Rear and Side Walls with Building Overhang



Side by Side—High Rear and Front Walls with Building Overhang



# INSTALLING OUTDOOR UNITS INDOORS

## Installing Outdoor Units Indoors

LG outdoor units are engineered to be mounted outdoors and include technology designed to minimize the negative effects of winter weather's freezing rain, sleet, and snow. Some building projects, however, necessitate placing the HVAC outdoor units indoors:

- Lack of ground space.
- Lack of an appropriate outdoor location that meets system design requirements.
- When mounting on the roof is not an option due to a lack of roof space.
- Roof warranty will be voided if mechanical equipment is placed on the membrane.
- On retrofit projects, a former chiller / boiler / air handler equipment room, mechanical area, or penthouse already exists.
- Where a project has vertical, self-contained VAV air handlers on each floor (in lieu of a centralized mechanical room).
- To curtail the potential need for redundant zone heating devices such as wall-fin radiators or duct heaters.
- In extremely cold environments where there is a significant amount of run-time at temperatures well below freezing outside the outdoor unit ambient air temperature range published in this engineering manual.

### Benefits of Installing Outdoor Units Indoors

- Shelters the outdoor unit from direct exposure to prevailing winds that decrease the heating capability of the outdoor unit.
- Protects equipment from freezing precipitation and / or potential ice build-up that could hinder unit operation.
- Maintains coil heat transfer efficiency by reducing the number of and shortening the cycle time for defrost operation.
- Easier maintenance and servicing during inclement weather.
- When mounted in a fully enclosed space, limiting the ambient air temperature may allow the system designer to eliminate oversizing the outdoor unit to compensate for loss of capacity at low ambient temperatures.
- May also curtail the need to provide inefficient redundant zone heating devices such as wall-fin radiators and second-stage ancillary heating devices.

### Design Considerations Include:

- Enclosure types and elements such as louvers, rain hoods, dampers and controls, heating methods and sizing of heating devices
- Heating strategies
- Duct design
- Condensate handling

### General Guidelines

- Follow ASHRAE 62.1 design guidelines.
- Depending on the project / application, a roof over the outdoor units in combination with a wind break may be all that is necessary.
- Consider the potential for snow accumulation near louvers / roof openings. Outside air intakes and discharge ducts/louvers must be engineered to clear anticipated snow accumulation levels by at least one (1) foot.
- In situations where operation is anticipated at temperatures of  $-13^{\circ}\text{F}$  and lower, ancillary heat must be provided to heat the outdoor unit coils to assure continuous compressor operation and heating.

It may be necessary to use an air guide accessory to prevent discharge air from short-cycling back to the coil inlet.

- Another option is to field manufacture ductwork and mount on top of the unit to encompass the outdoor unit fan discharge and connect to the exterior discharge grille on the building.
- Avoid using a single duct on multi-fan units to prevent short cycling. Provide a dedicated duct for each outdoor unit fan discharge.
- Consider the direction of prevailing winds and opening placement. If possible, locate inlet openings upwind of discharge openings and other exhaust outlets.
- When inlet and outlet openings are placed on the same wall, minimum distance between the two openings must be approximately three (3) feet (minimum distance varies significantly with variations in outlet opening face velocity).
- If roof-mounted ventilation openings are used, strategically locate the inlet ventilation opening(s) upwind of the outlet opening(s).
- Discharge and supply ductwork must be designed to avoid weather related long periods of water entrainment and the potential for microbial growth.

# INSTALLING OUTDOOR UNITS INDOORS

---

---

Provide a means to drain the condensate generated during heating mode and defrost cycle in addition to rainwater that infiltrates the inlet louver enclosed area.

- Install a field-provided drain pan under the outdoor units and provide a path to a nearby floor drain.
- If the ambient air temperature is expected to drop below 32°F in the enclosure, heat the bottom surface of the pan, drain line, and floor drain so that the condensate does not freeze before reaching the drain.

Allow for ventilation intake and exhaust air based on maximum outdoor unit fan capacity.

- Select the size, type and orientation of architectural louvers with adequate "net free area" face velocity to ensure the total external static pressure from the outdoor unit fan does not exceed design limitations (see specification data tables).
- Ⓞ No obstructions must be placed in front of the louver that could hamper the free flow (throw) of air.
- Roof top openings and / or discharge and supply louvers must be equipped with screens to prevent bird and insect infiltration.

As always, the best solution for each project balances acceptable heating performance (considering local weather conditions), capital costs, life cycle energy consumption, and limitations set forth by local building codes.

# REFRIGERANT PIPING DESIGN

## Design Guideline Summary

### Device Connection Limitations

A single-zone system consists of one outdoor unit and one indoor unit. One of the most critical elements of a single-zone system is the refrigerant piping. The table below lists pipe length limits that must be followed in the design of a single-zone Vertical Air Handling Unit refrigerant pipe system.

Table 48: Single-Zone Vertical Air Handling Unit Refrigerant Piping System Limitations.

System Model Name		LV181HV4, LV241HV4	LV361HV4, LV420HV, LV480HV
Pipe Length (ELF = Equivalent Length of Pipe in Feet)	Longest total equivalent piping length	164 feet	246 feet
	Shortest total equivalent piping length	6.6 feet	6.6 feet
	Distance between fittings and indoor or outdoor units	≥20 inches	≥20 inches
	No additional refrigerant	24.6 feet	24.6 feet
Elevation (All Elevation Limitations are Measured in Actual Feet)	If outdoor unit is above indoor unit	98 feet	98 feet
	If outdoor unit is below indoor unit	98 feet	98 feet
Additional Refrigerant Needed (oz/ft)		0.43	0.43

### System Layout

Figure 63: Typical LV181HV4 and LV241HV4 System Layout.

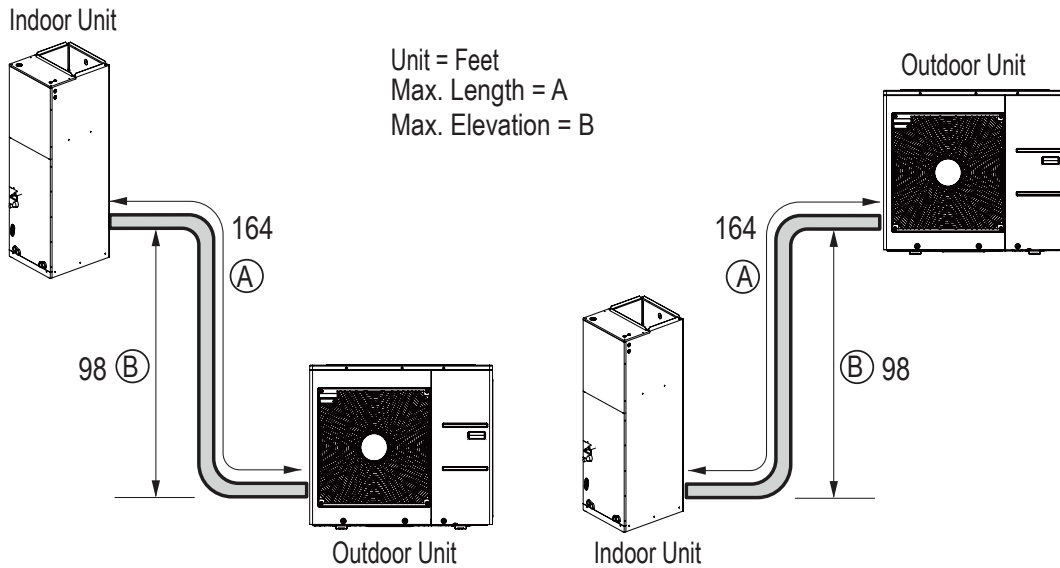

# REFRIGERANT PIPING DESIGN

## Design Guideline Summary

### System Layout

Figure 64: Typical LV361HV4, LV420HV and LV480HV System Layout.

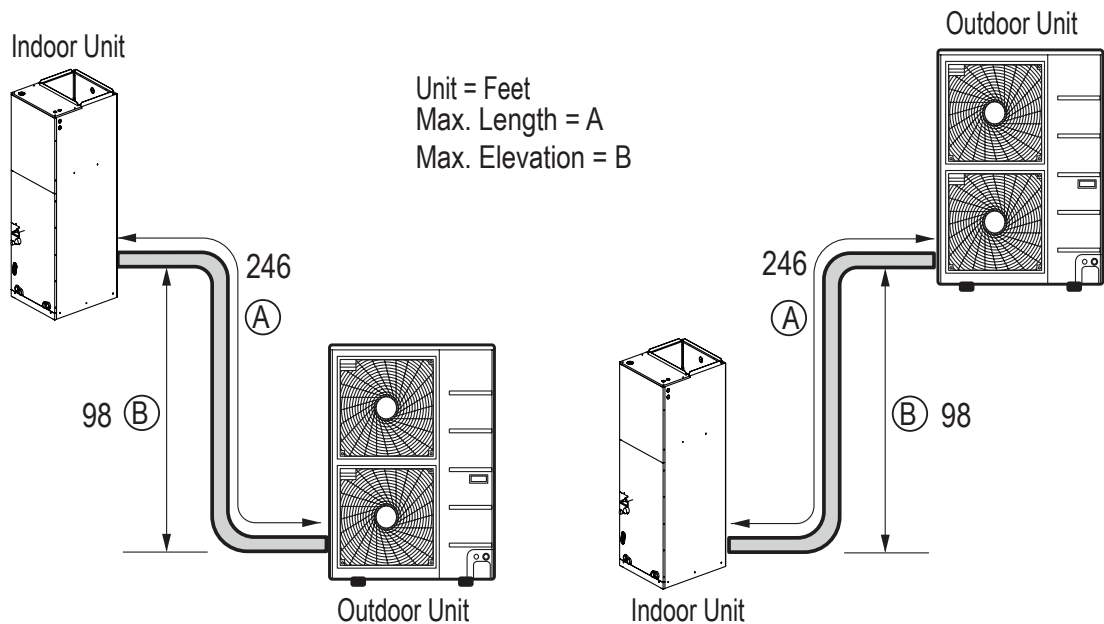

*Inverter*



LG Electronics, U.S.A., Inc.  
Air Conditioning Technologies  
4300 North Point Parkway  
Alpharetta, Georgia 30022  
[www.lghvac.com](http://www.lghvac.com)

EM\_SZ\_Vertical\_Air\_Handling\_Unit\_09\_19A  
Supersedes: EM\_SZ\_Vertical\_Air\_Handling\_Unit\_09\_19  
EM\_SZ\_Vertical\_Air\_Handling\_Unit\_02\_18  
EM\_SZ\_Vertical\_Air\_Handling\_Unit\_12\_17  
EM\_SZ\_Vertical\_Air\_Handling\_Unit\_09\_17