



Installation  
and  
Maintenance  
Manual  
7/21/17



## ***Low Profile Unit Cooler Air, Electric And Hot Gas Defrost Models***

### ***INSPECTION***

When the equipment is received, check the quantity of cartons and crates against the bill of lading. Inspect all containers for visible damage. Report any damage or shortages to the freight company immediately. It is the customer's responsibility to file all claims with the freight company.

### ***INSTALLATION***

Installation and maintenance are to be performed by qualified personnel who are familiar with local codes and regulations. Installers should have previous experience with this type of equipment.

***CAUTION: Avoid contact with sharp edges and coil surfaces. They are potential hazards.***

Determine the best location for the unit in the walk-in cooler or freezer. Place the unit as far as possible from any door openings. This will help to prevent warm, moist air from being drawn into the unit, reducing the potential for icing problems. Low Profile models are draw-through type units, which discharge air directly from the fan into the room.

Adequate clearances should be maintained to allow for proper air flow through the unit and to allow for regular maintenance and service. (See Page 4 for recommended location guidelines).

Remove all packaging materials before the unit is raised into position. Be certain that the unit is not set on the drain fitting or refrigerant connections before installation. The unit should be hung using 5/16 inch stainless steel rods or bolts at all hanger slots. The unit must be positioned flush with the ceiling with any gaps properly caulked.

The drain line should be pitched a minimum of 4 inches per foot to allow proper drainage and should exit the room as quickly as possible. Do not reduce the drain line size. All drain lines must be trapped outside of the enclosure where the temperature is never below 35°F. Drain lines should run to an open drain and should never be connected directly to a sewage or waste line. Drain lines should be heated and insulated to prevent freezing.

## Installation and Maintenance Manual

### ***Low Profile Unit Cooler***

#### ***Wiring***

All wiring must be done in compliance with local and national codes. Use only copper conductors.

Electric defrost units are supplied with a defrost termination fan delay thermostat (DTFD). The thermostat terminates the defrost cycle when a fixed temperature is reached. Additionally, the fan delay function allows the warm coil to cool after a defrost cycle, prior to the fans turning on. A heater safety thermostat is installed to prevent heaters from overheating above 75°F.

#### ***Expansion Valve***

Expansion valves should be selected and installed in accordance with the valve manufacturers recommendations. All units require externally equalized expansion valves and must have the equalizer line connected. The expansion valve bulb must be insulated and securely clamped at the 4 o'clock or 8 o'clock position on a horizontal run of the suction line. Proper location and full contact of the bulb is extremely important to the performance of the system.

New expansion valves usually need to be adjusted. Superheat settings should be checked after the system has run long enough to reach a balanced state. Low and medium temperature systems will usually operate more efficiently with a superheat setting of 6.5°F at design room temperature (always maintain a 20°F compressor superheat)

##### *To Obtain Evaporator Superheat:*

1. Measure the suction line temperature at the expansion valve bulb with an accurate electronic thermometer.
2. Obtain a suction pressure reading at the Schrader fitting at the evaporator suction connection.
3. Convert the pressure reading to temperature by using a temperature/pressure conversion chart.
4. Subtract the converted temperature from the measured temperature. The resulting difference represents the evaporator, superheat. (For close coupled systems, it may be necessary to increase the evaporator superheat to insure the minimum acceptable superheat at the compressor.)

The maximum recommended evaporator TD for medium temperature systems is 15°F. The maximum recommended TD for low temperature systems is 13°F.

#### ***Evacuation***

Proper installation procedures must include a deep evacuation of the system. A clean/dry system is essential when charging refrigerant.

#### ***General Maintenance***

Disconnect all electrical power to the unit before inspecting or cleaning. Evaporator coils, for blades and guards should be checked periodically and cleaned of all dirt or grease accumulation. Do not use ammonia or other cleaning agents that are corrosive to Copper or Aluminum. The drain pan should be lowered and thoroughly cleaned to permanently clear any drain restriction. The fan motors are permanently lubricated and do not require periodic oiling.

# TYPICAL WIRING DIAGRAMS

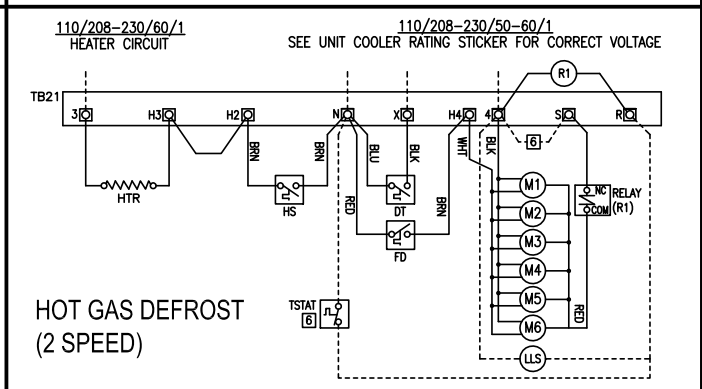
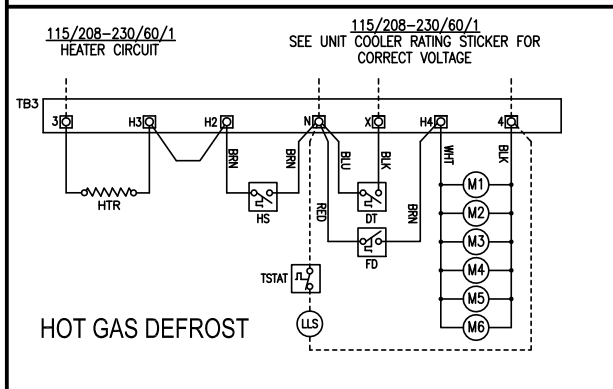
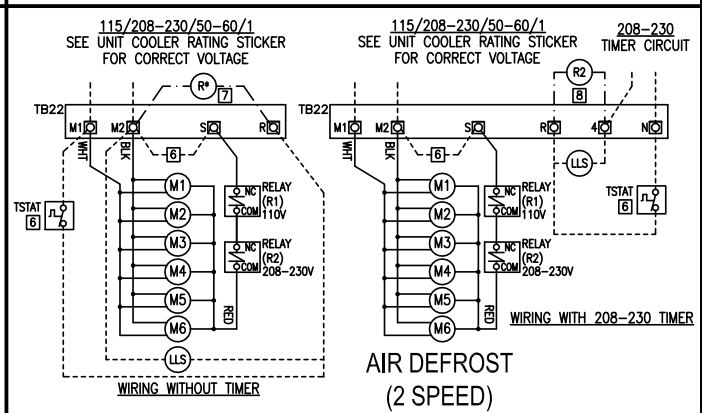
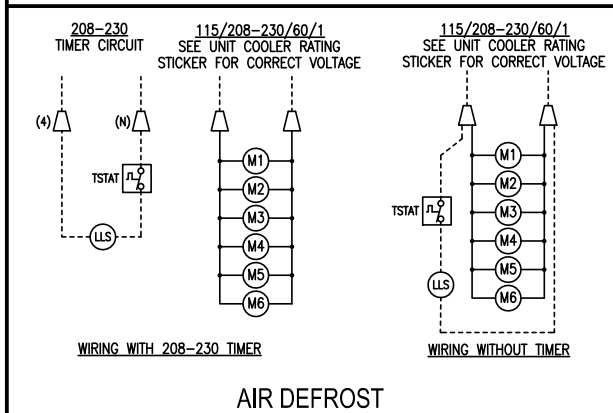
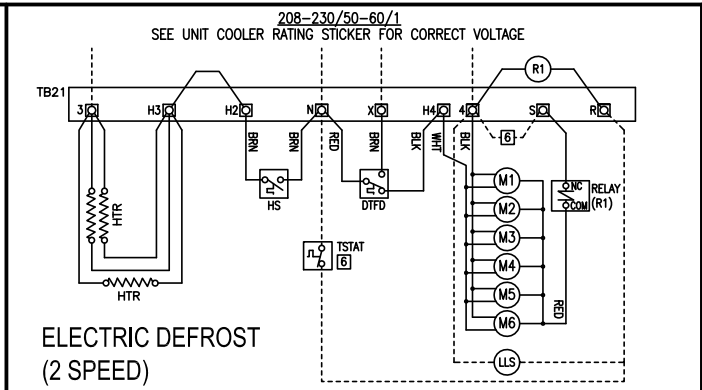
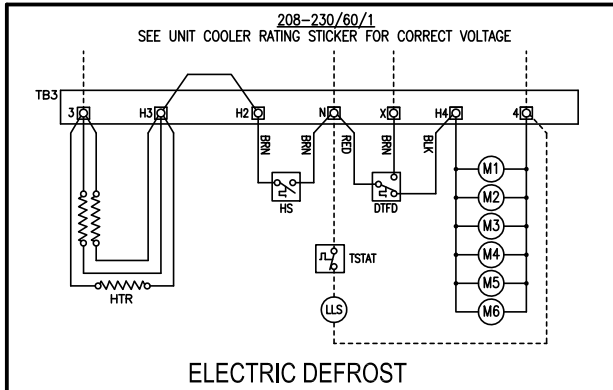

**NOTES:**

1. USE COPPER CONDUCTORS ONLY.
2. UNIT MUST BE GROUNDED.
3. 4, 3, N, & X TERMINALS FOR PARAGON TYPE 8145 TIMER.
4. FOR MOTOR AND HEATER AMPS SEE RATING STICKER ON OUTSIDE OF UNIT.
5. JUMPERS ARE 16 GA.
6. FOR 2-SPEED OPERATION ONLY, ADD JUMPER FROM S TO BLACK MOTOR WIRE. TSTAT IS REQUIRED TO CONTROL RELAY.
7. FOR 2-SPEED OPERATION ONLY, ADD JUMPER FROM M2 AND R TO COIL MATCHING SUPPLY VOLTAGE (R\*).
8. FOR 2-SPEED OPERATION ONLY, ADD JUMPER FROM 4 AND R TO COIL (R2).

**LEGEND:**

- TB - TERMINAL BOARD
- HTR - HEATER
- HS - HEATER SAFETY
- DTFD - DEFOST TERMINATION & FAN DELAY
- M1 - MOTOR #1, ETC.
- TSTAT - THERMOSTAT
- LLS - LIQUID LINE SOLENOID
- R1 - RELAY

**FACTORY WIRING** ———

- FIELD WIRING - - - - -
- FACTORY JUMPER - - - - -

