

# INSTALLATION INSTRUCTIONS

## R-410A Split System Heat Pumps

### WCH6

**These instructions must be read and understood completely before attempting installation.**

**IMPORTANT:** Effective January 1, 2015, all split system and packaged air conditioners must be installed pursuant to applicable regional efficiency standards issued by the Department of Energy.

### Safety Labeling and Signal Words

#### **DANGER, WARNING, CAUTION, and NOTE**

The signal words **DANGER**, **WARNING**, **CAUTION**, and **NOTE** are used to identify levels of hazard seriousness. The signal word **DANGER** is only used on product labels to signify an immediate hazard. The signal words **WARNING**, **CAUTION**, and **NOTE** will be used on product labels and throughout this manual and other manuals that may apply to the product.

**DANGER** - Immediate hazards which **will** result in severe personal injury or death.

**WARNING** - Hazards or unsafe practices which **could** result in severe personal injury or death.

**CAUTION** - Hazards or unsafe practices which **may** result in minor personal injury or product or property damage.

**NOTE** - Used to highlight suggestions which **will** result in enhanced installation, reliability, or operation.

#### **Signal Words in Manuals**

The signal word **WARNING** is used throughout this manual in the following manner:



The signal word **CAUTION** is used throughout this manual in the following manner:



#### **Signal Words on Product Labeling**

Signal words are used in combination with colors and/or pictures on product labels.

### **TABLE OF CONTENTS**

Safety Considerations .....	2
Installation Recommendations .....	2
Installation .....	2
Electrical Wiring .....	6
Defrost System .....	7
Start-up Procedure .....	9
General Sequence of Operation .....	10
R-410A Quick Reference Guide .....	11



#### **ELECTRICAL SHOCK HAZARD**

**Failure to follow this warning could result in personal injury and/or death.**

**Before installing, modifying, or servicing system, main electrical disconnect switch must be in the OFF position. There may be more than 1 disconnect switch. Lock out and tag switch with a suitable warning label.**



#### **CUT HAZARD**

**Failure to follow this caution may result in personal injury**

**Sheet metal parts may have sharp edges or burrs. Use care and wear appropriate protective clothing and gloves when handling parts.**

## SAFETY CONSIDERATIONS

Improper installation, adjustment, alteration, service, maintenance, or use can cause explosion, fire, electrical shock, or other conditions which may cause death, personal injury, or property damage. Consult a qualified installer, service agency, or your distributor or branch for information or assistance. The qualified installer or agency must use factory-authorized kits or accessories when modifying this product. Refer to the individual instructions packaged with the kits or accessories when installing.

Follow all safety codes. Wear safety glasses, protective clothing, and work gloves. Use quenching cloth for brazing operations. Have fire extinguisher available. Read these instructions thoroughly and follow all warnings or cautions included in literature and attached to the unit. Consult local building codes and current editions of the National Electrical Code (NEC) NFPA 70. In Canada, refer to current editions of the Canadian electrical code CSA 22.1.

Recognize safety information. This is the safety-alert symbol

**⚠** When you see this symbol on the unit and in instructions or manuals, be alert to the potential for personal injury. Understand these signal words; DANGER, WARNING, and CAUTION. These words are used with the safety-alert symbol. DANGER identifies the most serious hazards which **will** result in severe personal injury or death. WARNING signifies hazards which **could** result in personal injury or death. CAUTION is used to identify unsafe practices which **would** result in minor personal injury or product and property damage. NOTE is used to highlight suggestions which **will** result in enhanced installation, reliability, or operation.

## INSTALLATION RECOMMENDATIONS

**NOTE:** In some cases noise in the living area has been traced to gas pulsations from improper installation of equipment.

1. Locate unit away from windows, patios, decks, etc. where unit operation sound may disturb customer.
2. Ensure that vapor and liquid tube diameters are appropriate for unit capacity.
3. Run refrigerant tubes as directly as possible by avoiding unnecessary turns and bends.
4. Leave some slack between structure and unit to absorb vibration.
5. When passing refrigerant tubes through the wall, seal opening with RTV or other pliable silicon-based caulk. (See Fig. 1.)
6. Avoid direct tubing contact with water pipes, duct work, floor joists, wall studs, floors, and walls.
7. Do not suspend refrigerant tubing from joists and studs with a rigid wire or strap which comes in direct contact with tubing. (See Fig. 1.)
8. Ensure that tubing insulation is pliable and completely surrounds vapor tube.
9. When necessary, use hanger straps which are 1 in. (25.4 mm) wide and conform to shape of tubing insulation. (See Fig. 1.)
10. Isolate hanger straps from insulation by using metal sleeves bent to conform to shape of insulation.

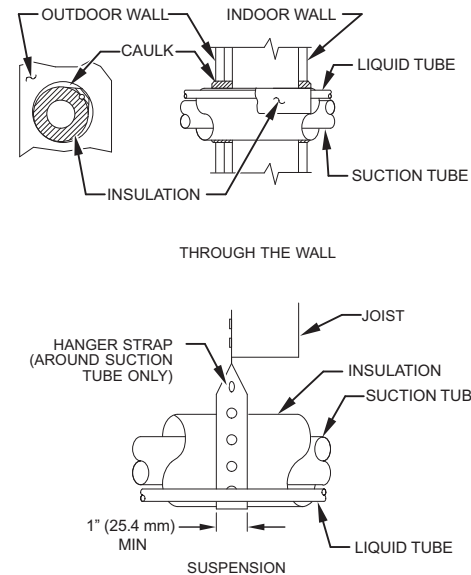

Fig. 1 - Connecting Tube Installation

A07588

When outdoor unit is connected to factory-approved indoor unit, outdoor unit contains system refrigerant charge for operation with AHRI rated indoor unit when connected by 15 ft. (4.57 m) of field-supplied or factory accessory tubing. For proper unit operation, check refrigerant charge using charging information located on control box cover and/or in the Check Charge section of this instruction.

**IMPORTANT:** Maximum liquid-line size is 3/8-in. OD for all residential applications including long line.

**IMPORTANT:** Always install the factory-supplied liquid-line filter drier. Obtain replacement filter driers from your distributor or branch.

## INSTALLATION

### Check Equipment and Job Site

#### Unpack Unit

Move to final location. Remove carton taking care not to damage unit.

#### Inspect Equipment

File claim with shipping company prior to installation if shipment is damaged or incomplete. Locate unit rating plate on unit corner panel. It contains information needed to properly install unit. Check rating plate to be sure unit matches job specifications.

#### Install on a Solid, Level Mounting Pad

If conditions or local codes require the unit be attached to pad, tie down bolts should be used and fastened through knockouts provided in unit base pan. Refer to unit mounting pattern in Fig. 2 to determine base pan size and knockout hole location.

For hurricane tie downs - contact your local distributor for details and PE (Professional Certification), if required by local authorities.

On rooftop applications, mount on level platform or frame. Place unit above a load-bearing wall and isolate unit and tubing set from structure. Arrange supporting members to adequately support unit and minimize transmission of vibration to building. Consult local codes governing rooftop applications.

Roof mounted units exposed to winds may require wind baffles. Consult the Low-Ambient pressure switch installation instructions for wind baffle construction.

**NOTE:** Unit must be level  $\pm$  2 degrees [3/8 inch rise or fall per foot of run (10mm rise or fall per 305 mm of run)] or compressor may not function properly.

**Clearance Requirements**

When installing, allow sufficient space for airflow clearance, wiring, refrigerant piping, and service. Allow 24 in. (610 mm) clearance to service end of unit and 48 in. (1219.2 mm) above unit. For proper airflow, a 6 in. (152.4 mm) clearance on one side of unit and 12 in. (304.8 mm) on all remaining sides must be maintained. Maintain a distance of 24 in. (609.6 mm) between units or 18 in. (457.2 mm) if no overhang within 12 ft. (3.66m). Position so water, snow, or ice from roof or eaves cannot fall directly on unit.

3/8-in. (9.53 mm) Dia. Tiedown Knockouts in Basepan(2) Places

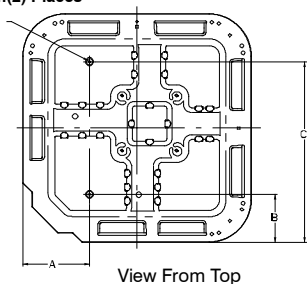

UNIT BASE PAN Dimension in. (mm)	TIEDOWN KNOCKOUT LOCATIONS in. (mm)		
	A	B	C
31-1/2 X 31-1/2 (800 X 800)	9-1/8 (231.8)	6-9/16 (166.7)	24-11/16 (627.1)
35 X 35 (889 X 889)	9-1/8 (231.8)	6-9/16 (166.7)	28-7/16 (722.3)

Fig. 2 - Tiedown Knockout Locations

On rooftop applications, locate unit at least 6 in. (152.4 mm) above roof surface.

**Operating Ambient**

The minimum outdoor operating ambient in cooling mode is 55°F (12.78°C) without low ambient cooling enabled, and the maximum outdoor operating ambient in cooling mode is 125°F (51.67°C). The maximum outdoor operating ambient in heating mode is 66°F (18.89°C)

**Elevate Unit**

**⚠ CAUTION**

**UNIT DAMAGE HAZARD**

Failure to follow this caution may result in equipment damage or improper operation.

Unit must be kept free of an accumulation of water and/or ice in the basepan.

Elevate unit per local climate and code requirements to provide clearance above estimated snowfall level and ensure adequate drainage of unit. If using accessory support feet, use installation instructions from kit for installation.

**⚠ CAUTION**

**UNIT DAMAGE HAZARD**

Failure to follow this caution may result in equipment damage or improper operation.

To prevent damage to the unit, ensure that it is located with the supports such that the unit is stable in all circumstances including adverse conditions.

**Make Piping Connections**

**⚠ WARNING**

**PERSONAL INJURY AND ENVIRONMENTAL HAZARD**

Failure to follow this warning could result in personal injury or death.

Relieve pressure and recover all refrigerant before system repair or final unit disposal.

Use all service ports and open all flow-control devices, including solenoid valves.

**⚠ CAUTION**

**UNIT DAMAGE HAZARD**

Failure to follow this caution may result in equipment damage or improper operation.

Do not leave system open to atmosphere any longer than minimum required for installation. POE oil in compressor is extremely susceptible to moisture absorption. Always keep ends of tubing sealed during installation.

If ANY refrigerant tubing is buried, provide a 6 in. (152.4 mm) vertical rise at service valve. Refrigerant tubing lengths up to 36 in. (914.4 mm) may be buried without further special consideration. Do not bury lines more than 36 in. (914.4 mm).

**⚠ WARNING**

**PERSONAL DAMAGE HAZARD**

Failure to follow this warning may result in equipment damage or improper operation.

To prevent damage to unit or service valves, observe the following:

- Use a brazing shield.
- Wrap service valves with wet cloth or use a heat sink material.

Outdoor units may be connected to indoor section using accessory tubing package or field-supplied refrigerant grade tubing of correct size and condition. For tubing requirements beyond 80 ft/24.38 m, substantial capacity and performance losses can occur. Following the recommendations in the Long Line Applications Guideline will reduce these losses. Refer to Table 1 for accessory requirements. Refer to Table 2 for field tubing diameters.

If refrigerant tubes or indoor coil are exposed to atmosphere, they must be evacuated to 500 microns to eliminate contamination and moisture in the system.

Table 1 - Accessory Usage

Accessory	REQUIRED FOR LOW-AMBIENT COOLING APPLICATIONS (Below 55°F / 12.8°C)	REQUIRED FOR LONG LINE APPLICATIONS*	REQUIRED FOR SEA COAST APPLICATIONS (Within 2 miles / 3.22 km)
Accumulator	Standard	Standard	Standard
Compressor Start Assist Capacitor and Relay	Yes	Yes	No
Crankcase Heater	Yes	Yes	No
Evaporator Freeze Thermostat	Yes	No	No
Isolation Relay	Yes	No	No
Liquid Line Solenoid Valve	No	See Long-Line Application Guideline	No
Low Ambient Switch	Yes‡	No	No
Support Feet	Recommended	No	Recommended

\* For tubing line sets between 80 and 200 ft. (24.38 and 60.96 m) and/or 20 ft. (6.09 m) vertical differential, refer to Residential Piping and Longline Guideline.  
 ‡ In units equipped with ECM OD motor, motor needs to be replaced per unit accessory guide to work properly. This motor kit comes with a new defrost board that also needs to be installed. Unit will not meet AHRI rated efficiency once motor and defrost board are replaced to use this accessory.

Table 2 - Refrigerant Connections and Recommended Liquid and Vapor Tube Diameters (In.)

UNIT SIZE	LIQUID		RATED VAPOR up to 80 ft. (24.38 m)*	
	Connection Diameter	Tube Diameter	Connection Diameter	Rated Tube Diameter
18, 24	3/8	3/8	5/8	5/8
30, 36	3/8	3/8	3/4	3/4
42, 48	3/8	3/8	7/8	7/8
60	3/8	3/8	7/8	1-1/8

\* Units are rated with 25 ft. (7.6 m) of lineset. See Specification sheet for performance data when using different size and length linesets.

**Notes:**

- Do not apply capillary tube or fixed orifice indoor coils to these units.
- For Tubing Set lengths between 80 and 200 ft. (24.38 and 60.96 m) horizontal or 35 ft. (10.7 m) vertical differential 250 ft. (76.2 m) Total Equivalent Length), refer to the Long Line Applications Guideline.

**Outdoor Unit Connected to Factory Approved Indoor Unit**

These outdoor units are carefully evaluated and listed with specific indoor coils for proper system performance.

**Install Adapter Tube (36, 42, and 60 Units Only)**

- Remove plastic retainer holding outdoor piston in liquid service valve.
- Check outdoor piston size with matching number listed on unit rating plate.
- Locate plastic bag taped to unit containing adapter tube.
- Remove Teflon® seal from bag and install on open end of liquid service valve. (See Fig. 3.)
- Remove adapter tube from bag and connect threaded nut to liquid service valve. Tighten nut finger-tight and then with wrench an additional 1/2 turn (15 ft-lb). **DO NOT OVER TIGHTEN!**

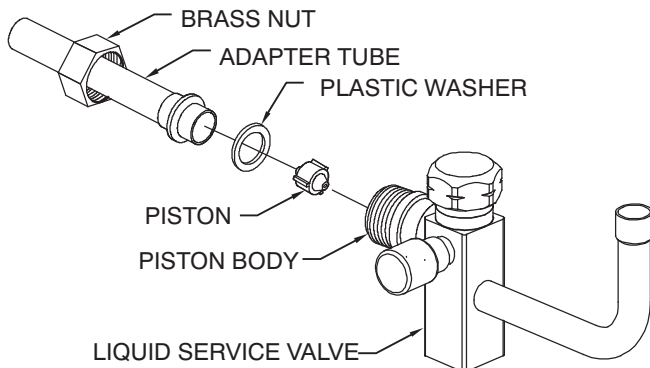

Fig. 3 - Liquid Service Valve

**NOTE:** 18, 24, 30, and 48 units have an OD TXV installed for heating expansion and do not require a piston. These units have a standard AC liquid service valve.

**Refrigerant Tubing and Sweat Connections**

Connect vapor tube to fitting on outdoor unit vapor service valves (see Table 2.) Connect liquid tubing to adapter tube on liquid service valve (36, 42, 60) or to liquid service valve (18, 24, 30, 48). Use refrigerant grade tubing.

**⚠ CAUTION**

**UNIT DAMAGE HAZARD**

Failure to follow this caution may result in equipment damage or improper operation.

Service valves must be wrapped in a heat-sinking material such as a wet cloth while brazing.

**⚠ CAUTION**

**UNIT DAMAGE HAZARD**

Failure to follow this caution may result in equipment damage or improper operation.

Installation of filter drier in liquid line is required.

**Install Liquid Line Filter Drier Indoor**

Refer to Fig. 4 and install filter drier as follows:

- Braze 5 in. (127 mm) liquid tube to the indoor coil.
- Wrap filter drier with damp cloth.
- Braze filter drier to 5 in. (127 mm) liquid tube from step 1.
- Connect and braze liquid refrigerant tube to the filter drier.

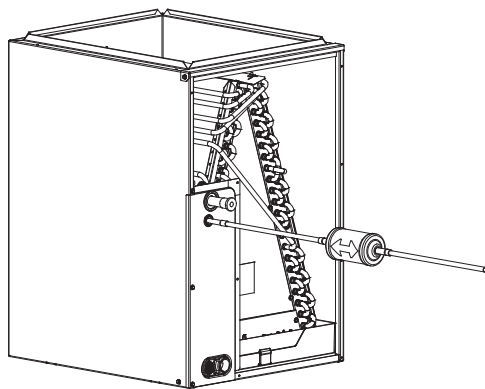

Fig. 4 - Liquid Line Filter Drier

**Leak Testing**

Leak test all joints; indoors, outdoors, and refrigerant tubing.

**Evacuate Refrigerant Tubing and Indoor Coil**

**CAUTION**

**UNIT DAMAGE HAZARD**

Failure to follow this caution may result in equipment damage or improper operation.

Never use the system compressor as a vacuum pump.

Refrigerant tubes and indoor coil should be evacuated using the recommended deep vacuum method of 500 microns. An alternate triple evacuation method may be used. See triple evacuation method in Service Manual.

**IMPORTANT:** Always break a vacuum with dry nitrogen.

**Deep Vacuum Method**

The deep vacuum method requires a vacuum pump capable of pulling a vacuum of 500 microns and a vacuum gage capable of accurately measuring this vacuum depth. The deep vacuum method is the most positive way of assuring a system is free of air and liquid water. (See Fig.5)

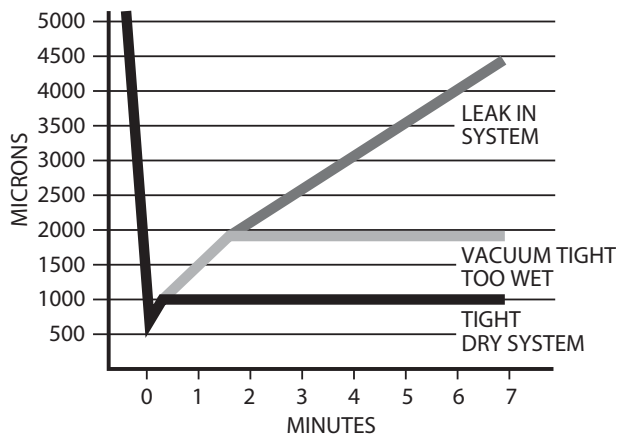

Fig. 5 - Deep Vacuum Graph

**Final Tubing Check**

**IMPORTANT:** Check to be certain factory tubing on both indoor and outdoor unit has not shifted during shipment. Ensure tubes are not rubbing against each other or any sheet metal. Pay close attention to feeder tubes, making sure wire ties on feeder tubes are secure and tight, as applicable.

**ELECTRICAL WIRING**

**WARNING**

**ELECTRICAL SHOCK HAZARD**

Failure to turn off the main (remote) electrical disconnect device could result in personal injury or death.

**Before installing, modifying or servicing system, turn OFF the main (remote) electrical disconnect device. There may be more than one disconnect device.**

Supply voltage must be 208/230 volts (197 volt minimum to 253 volts maximum) 60 Hz single phase or 3-phase for designated units.

Outdoor units are approved for use with copper conductors only. Do not use aluminum wire.

Refer to unit rating plate for minimum circuit ampacity and circuit protection requirements.

**Grounding**

Permanently ground unit in accordance with the National Electrical Code and local codes or ordinances. Use a copper conductor of the correct size from the grounding lug in control box to a grounded connection in the service panel or a properly driven and electrically grounded ground rod.

**Wiring Connections**

Make all outdoor electrical supply (Line Voltage) connections with raintight conduit and fittings. Most codes require a disconnect switch outdoors within sight of the unit. Consult local codes for special requirements. Route electrical supply (Line Voltage) wiring through knockout hole in bottom of Control Box. Connect wires to Contactor and Ground Lug according to Wiring Diagram on unit. Refer to Figure 6.

Route thermostat wiring through rubber grommet in bottom of Control Box. Low voltage lead wires are provided in the control box for connection to thermostat wires (use wire nuts). Refer to Wiring Diagram on unit and Figure 7 for low voltage wiring examples.

**NOTE:** Use No. 18 AWG (American Wire Gage) color-coded, insulated (35 °C minimum) wire. If thermostat is located more than 100 feet (30.5 m) from unit as measured along the control voltage wires, use No. 16 AWG color-coded wires to avoid excessive voltage drop.

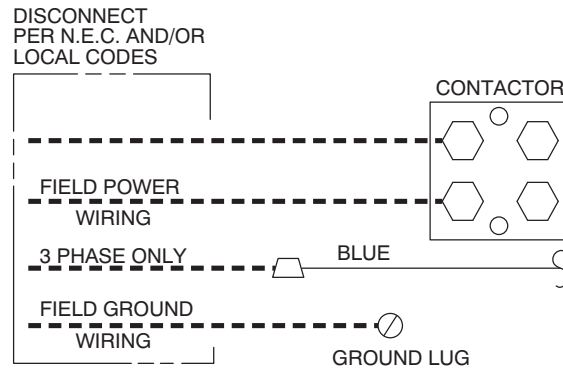

Fig. 6 - Electrical Supply (Line Voltage) Connections

A94025

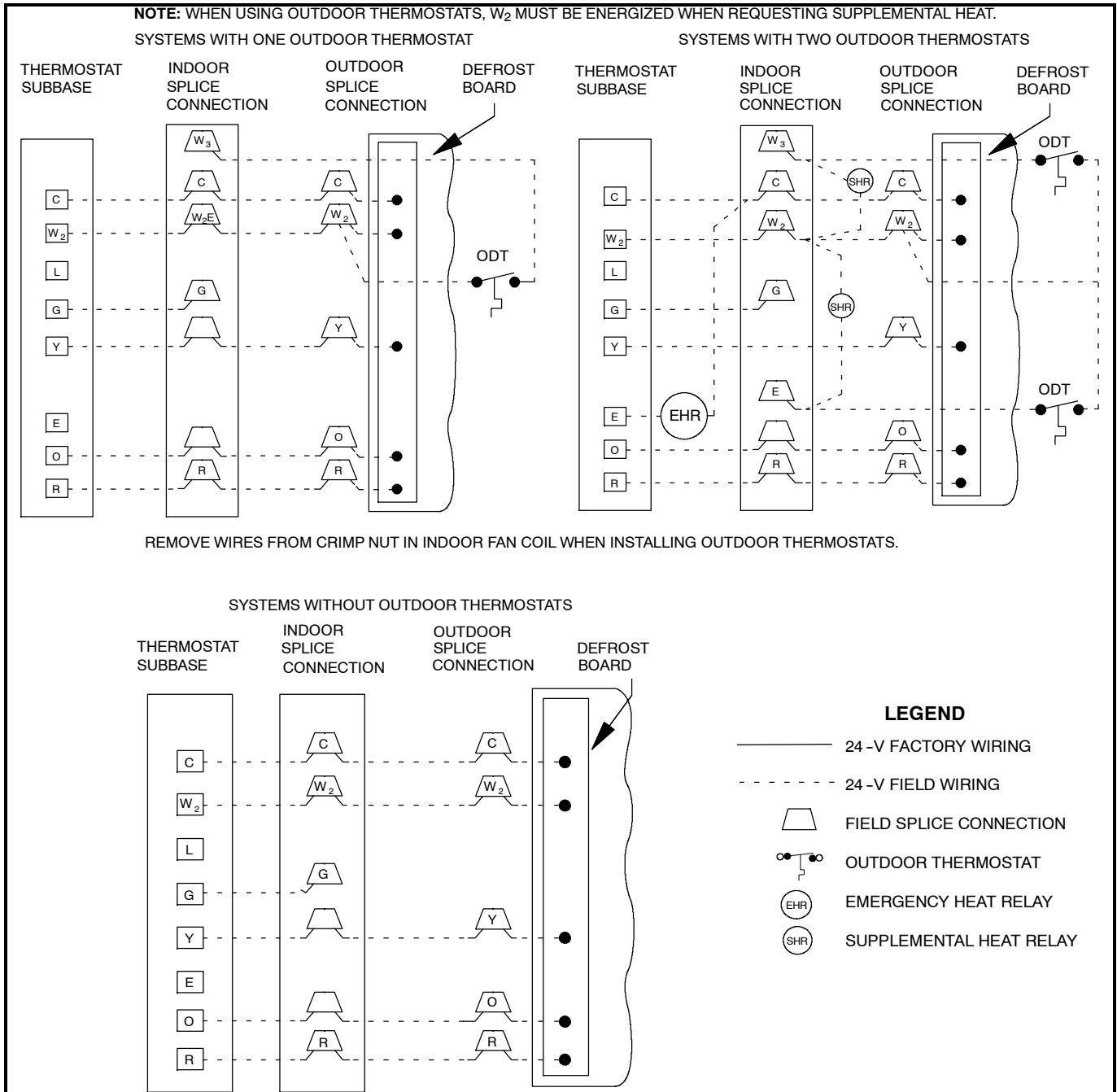
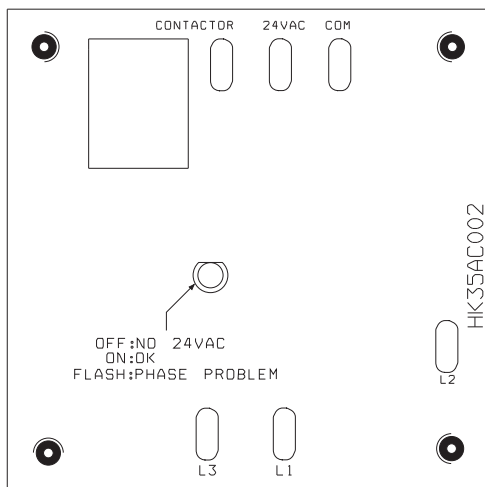

Fig. 7 - Typical Thermostat (Control Circuit) Connections



**Fig. 8 - 3-Phase Monitor Control**  
(Applies to 3-Phase Units Only)

A00010

**3-Phase Monitor LED Indicators**

LED	STATUS
OFF	No call for compressor operation
FLASHING	Reversed phase
ON	Normal

**DEFROST SYSTEM**

**A. DEFROST THERMOSTAT**

The defrost thermostat is factory installed on a short tube stub extending from the coil end plate. Refer to Figure 9 and confirm that the thermostat is securely fastened in place on the tube stub.

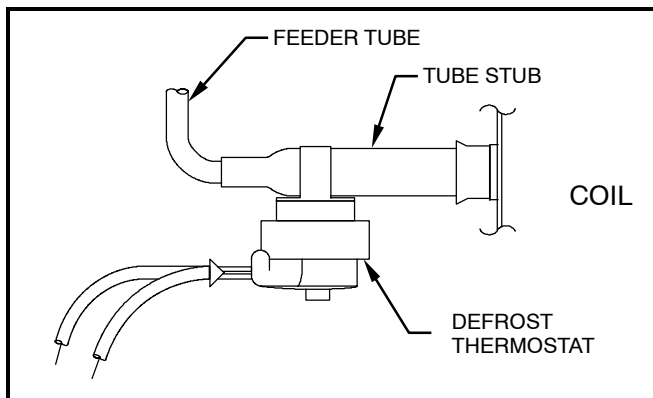

**Fig. 9 - Defrost Thermostat**

**B. DEFROST CONTROL BOARD**

The defrost board is a time/temperature control which includes a field-selectable time period between defrost cycles of 30, 60, or 90 minutes (quick-connects located at board edge, factory set at 60 or 90 minutes).

Defrost mode is identical to cooling mode except that outdoor-fan motor stops and second-stage heat is turned on to continue warming conditioned space.

Initially, the defrost cycle timer starts when the contactor is energized and a 24 VAC signal is present on the T1 terminal. Then the defrost cycle begins when the defrost

thermostat is closed and the cycle timer times out (30, 60, or 90 minutes).

There are two **timers** involved in the defrost sequence: **Interval Timer** – 30, 60, or 90 minutes, selected by setting the jumper on the defrost board. Timer is only active during calls for heating. Timer starts when the defrost thermostat closes 32° F (0° C). Timer stops when a defrost is initiated by the defrost board or when the defrost thermostat opens 65° F (18° C).

**Defrost Timer** – 10 minutes, not adjustable. Timer is only active while the coil is defrosting. Timer starts when the defrost board initiates a defrost. Timer stops when the defrost thermostat opens 65° F (18° C) or after timing out at 10 minutes (whichever comes first).

**SPEEDUP** pins are provided on the defrost board to help in troubleshooting without waiting for timers to expire. Jumpering the SPEEDUP pins causes any active timer to run very fast (256 times normal speed). Jumpering the SPEEDUP pins does not by itself initiate any timers, it only affects timers that are already running or are already part of the sequence.

To initiate a forced defrost cycle (test cycle), the defrost thermostat (Figure 9) must be closed.

There are two ways to verify that the defrost thermostat is closed:

1. Jumper across the DFT terminals on the defrost board (Figure 9). With this method, the defrost thermostat is removed from the circuit, and operation of the defrost thermostat itself will not be observed. Skip to #3.
2. Use a volt-meter to confirm there is no voltage across the DFT leads. 24 volts across the DFT terminals indicates an OPEN defrost thermostat. Zero volts across the DFT terminals indicates a CLOSED defrost thermostat.

With this method, the operation of the defrost thermostat can be observed during the test. If the defrost thermostat is confirmed closed, skip to #3.

If the defrost thermostat is open (24 volts across DFT leads) it may be possible to close the defrost thermostat by forcing a frost buildup on the outdoor coil. Follow these steps:

- Turn off power to unit.
  - For units with PSC motors, disconnect outdoor fan-motor lead from the OF2 terminal on control board; For units with ECM motors, disconnect outdoor fan-motor lead from the ODF terminal. (Figure 9). Tape lead to prevent grounding.
  - Restart unit in heating mode; wait for accumulation of frost on outdoor coil. Use volt-meter to confirm there are zero volts across the DFT leads (thermostat closed).
  - Turn off power to unit. Replace outdoor fan-motor lead to either OF2 or ODF terminal on control board, depending on type of motor (Figure 9). Restart the unit in heating mode.
3. With unit running in heating mode and the defrost thermostat closed, the entire defrost sequence can be sped up for testing by shorting together the SPEEDUP pins on the defrost board. Use a flat-headed screwdriver to short the pins together.



4. Hold the SPEEDUP pins shorted together until the reversing valve shifts.  
SPEEDUP reduces whatever time was left on the interval timer (30/60/90 minutes). In normal operation the reversing valve will always shift with the SPEEDUP pins shorted for between 1 and 21 seconds.
5. After shorting the SPEEDUP pins together as described in #4, the reversing valve will energize (shift to AC mode), the outdoor fan will stop, the strip heat will energize, and the coil will begin to defrost. There are two options for the defrost test:
  - a. Remove the short from between the SPEEDUP pins immediately after the reversing valve shifts, and the unit will defrost for a shortened period of time (something less than 10 minutes). The defrost will stop when the defrost thermostat opens (reaches 65°F)(18°C) or when the defrost timer times out (something less than 10 minutes).
  - b. Leave the SPEEDUP pins shorted together for more than 2 seconds after the reversing valve shifts, and the unit will immediately return to heating operation (#6 below). Continue to leave the pins shorted together and the sequence starts over at #4 above.
6. Unit returns to heating mode after defrost sequence. Reversing valve shifts back, outdoor fan starts up, and strip heat de-energizes.

**START-UP PROCEDURE**

1. Set indoor thermostat selector switch to OFF.
2. Turn ON all electrical disconnect devices.
3. If unit has a crankcase heater, energize the heater and wait 24 hours before proceeding.
4. Set indoor thermostat at desired temperature. Be sure setpoint is below indoor ambient temperature to call for cooling, or above indoor ambient to call for heating.
5. Set indoor thermostat selector switch to COOL or HEAT. Operate unit for minimum 15 minutes, then check the system refrigerant charge.

**REFRIGERANT CHARGE**

Factory charge amount and desired subcooling are shown on unit rating plate. Charging method is shown on information plate inside unit. Additional subcooling may be required to achieve optimal heating performance based on installed indoor unit.

For TXV, use subcooling method.

For Piston, use superheat method.

To properly check or adjust charge, conditions must be favorable for subcooling or superheat charging. Favorable conditions exist when the outdoor temperature is between 70°F and 100°F (21°C and 38°C), and the indoor temperature is between 70°F and 80°F (21°C and 27°C). Follow the procedure below.

Unit is factory charged for 15 feet (4.6m) of lineset. Adjust charge by adding or removing 0.6 oz/ft (17 g/mm) of 3/8 liquid line above or below 15 feet (4.6 m) respectively.

For standard refrigerant line lengths 80 feet (24.4m) or less, allow system to operate in cooling mode at least 15 minutes. If conditions are favorable, check system charge by super heat method for fixed metering device and subcooling method for TXV. If any adjustment is necessary, adjust charge slowly and allow system to operate for 15 minutes to stabilize before declaring a properly charged system.

If the indoor temperature is above 80°F (27°C), and the outdoor temperature is in the favorable range, adjust system charge by weight based on line length and allow the indoor temperature to drop to 80°F (27°C) before attempting to check system charge by subcooling method as described above.

If the indoor temperature is below 70°F (21°C), or the outdoor temperature is not in the favorable range, adjust charge for line set length above or below 15 feet (4.6m) only. Charge level should then be appropriate for the system to achieve rated capacity. The charge level could then be checked at another time when the both indoor and outdoor temperatures are in a more favorable range.

**NOTE:** If line length is beyond 80 feet (24.4m) or greater than 20 feet (6.1m) vertical separation, See Long Line Guideline for special charging requirements.

**COOLING MODE**

Units installed with cooling mode TXV require charging by the subcooling method.

1. Operate unit a minimum of 15 minutes before checking charge.
2. Measure liquid service valve pressure by attaching an accurate gage to service port.
3. Measure liquid line temperature by attaching an accurate thermistor type or electronic thermometer to liquid line near outdoor coil.
4. Refer to unit rating plate for required subcooling temperature.
5. Refer to Table 3. Find the point where required subcooling temperature intersects measured liquid service valve pressure.
6. To obtain required subcooling temperature at a specific liquid line pressure, add refrigerant if liquid line temperature is higher than indicated or reclaim refrigerant if temperature is lower. Allow a tolerance of ±3°F (±1.7°C).

**C. HEATING MODE**

To check system operation during heating cycle, refer to the Tech Label on outdoor unit. This chart indicates whether a correct relationship exists between system operating pressure and air temperature entering indoor and outdoor units. If pressure and temperature do not match on chart, system refrigerant charge may not be correct. Do not use chart to adjust refrigerant charge.

**NOTE:** When charging is necessary during heating season, charge must be weighed in accordance with unit rating plate ±0.6 ounces per foot of 3/8 inch liquid line above or below 15 feet respectively (±17g per 305mm of 10mm liquid line above or below 4.6m respectively).



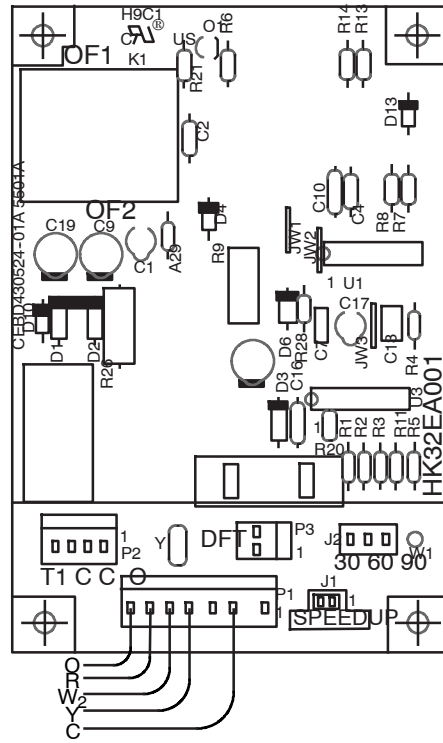

For units with PSC motors

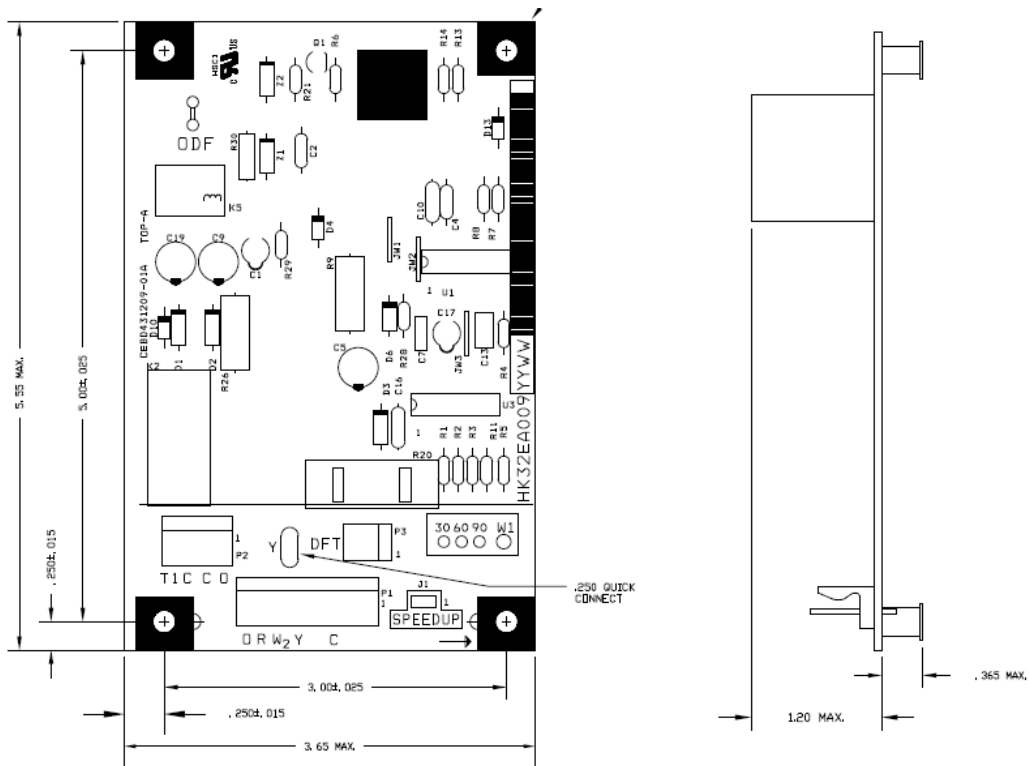

For units with ECM motors

Fig. 10 - Defrost Control Boards

## SEQUENCE OF OPERATION

### A. COOLING MODE

On a call for cooling, the thermostat makes circuits R-O, R-Y, and R-G. Circuit R-O energizes reversing valve, switching it to cooling position. Circuit R-Y energizes contactor, starting outdoor fan motor and compressor. Circuit R-G energizes indoor unit blower relay, starting indoor blower motor.

When thermostat is satisfied, its contacts open, de-energizing contactor and blower relay. Compressor and motors stop.

**NOTE:** If indoor unit is equipped with a time-delay relay circuit, the blower runs an additional length of time to increase system efficiency. (Applies to both cooling and heating modes.)

### B. HEATING MODE

On a call for heating, the thermostat makes circuits R-Y and R-G (circuit R-O is NOT made, and the reversing valve stays in the de-energized, heating position). Circuit R-Y energizes contactor, starting outdoor fan motor and compressor. Circuit R-G energizes indoor blower relay, starting blower motor. If the room temperature continues to fall, circuit R-W2 is made through the second-stage room thermostat bulb. Circuit R-W2 energizes a sequencer, bringing on the first bank supplemental electric heat and providing electrical potential to the second heater sequencer (if used). If outdoor temperature falls below the setting of the outdoor thermostat (field-installed option), contacts close to complete the circuit and bring on the second bank of supplemental electric heat.

When the thermostat is satisfied, its contacts open, de-energizing contactor, blower relay, and sequencer. Compressor, motors, and heaters stop.

**Table 3 - Rating Plate (required) Subcooling Temperature °F (°C)**

Measured Liquid Pressure (psig)	°F	(°C)	°F	(°C)	°F	(°C)	°F	(°C)	F	(°C)	F	(°C)
	6	3	8	4	10	6	12	7	14	8	16	9
	R-410A Required Liquid Line Temperature °F (°C)											
251	78	26	76	24	74	23	72	22	70	21	68	20
259	80	27	78	26	76	24	74	23	72	22	70	21
266	82	28	80	27	78	26	76	24	74	23	72	22
274	84	29	82	28	80	27	78	26	76	24	74	23
283	86	30	84	29	82	28	80	27	78	26	76	24
291	88	31	86	30	84	29	82	28	80	27	78	26
299	90	32	88	31	86	30	84	29	82	28	80	27
308	92	33	90	32	88	31	86	30	84	29	82	28
317	94	34	92	33	90	32	88	31	86	30	84	29
326	96	36	94	34	92	33	90	32	88	31	86	30
335	98	37	96	36	94	34	92	33	90	32	88	31
345	100	38	98	37	96	36	94	34	92	33	90	32
364	104	40	102	39	100	38	98	37	96	36	94	34
374	106	41	104	40	102	39	100	38	98	37	96	36
384	108	42	106	41	104	40	102	39	100	38	98	37
395	110	43	108	42	106	41	104	40	102	39	100	38
406	112	44	110	43	108	42	106	41	104	40	102	39
416	114	46	112	44	110	43	108	42	106	41	104	40
427	116	47	114	46	112	44	110	43	108	42	106	41
439	118	48	116	47	114	46	112	44	110	43	108	42
450	120	49	118	48	116	47	114	46	112	44	110	43
462	122	50	120	49	118	48	116	47	114	46	112	44
474	124	51	122	50	120	49	118	48	116	47	114	46

## R-410A QUICK REFERENCE GUIDE

- R-410A refrigerant operates at 50% – 70% higher pressures than R-22. Be sure that servicing equipment and replacement components are designed to operate with R-410A.
- R-410A refrigerant cylinders are rose colored.
- Recovery cylinder service pressure rating must be 400 psig, DOT 4BA400 or DOT BW400.
- R-410A systems should be charged with liquid refrigerant. Use a commercial type metering device in the manifold hose.
- Manifold sets should be 750 psig high-side and 200 psig low-side with 520 psig low-side retard.
- Use hoses with 750 psig service pressure rating.
- Leak detectors should be designed to detect HFC refrigerant.
- R-410A, as with other HFC refrigerants, is only compatible with POE oils.
- Vacuum pumps will not remove moisture from oil.
- Do not use liquid line filter-driers with rated working pressures less than 600 psig.
- Do not install a suction line filter-drier in liquid line.
- POE oils absorb moisture rapidly. Do not expose oil to atmosphere.
- POE oils may cause damage to certain plastics and roofing materials.
- Wrap all filter-driers and service valves with wet cloth when brazing.
- A liquid line filter-drier is required on every unit.
- Do not use with an R-22 TXV.
- If indoor unit is equipped with an R-22 TXV, it must be changed to an R-410A TXV.
- Never open system to atmosphere while it is under a vacuum.
- When system must be opened for service, break vacuum with dry nitrogen and replace all filter-driers.
- Do not vent R-410A into the atmosphere.
- Do not use capillary tube indoor coils.
- Observe all **WARNINGS, CAUTIONS, NOTES**, and **bold** text.