



EVERPURE® ENDURANCE® SC HIGH FLOW TRIPLE 1.1 SYSTEM

ALL THE BENEFITS OF THE ENDURANCE PLATFORM PLUS ULTRAFILTER MEMBRANE-BASED PRETREATMENT



Endurance High Flow Triple: EV9437-41

APPLICATIONS

Multiple equipment and combination applications
High volume installations

Locations with high submicron particulate content in water source

FEATURES • BENEFITS

High capacity allows system to keep up with high water demands and allows for 12-month estimated cartridge change-outs

High quality, ultrafiltration hollow fiber membranes are backward- and forward-flushed to remove built-up particle contaminants, providing long life to both the UF pretreatment membrane and the SEN Fine Filters

Backflushing occurs from the outside of the hollow membranes to the inside, which provides better dirt removal and reduced membrane breakage

Proprietary Fibredyne™ II media provides superior chlorine taste & odor reduction and micro-filters dirt and particles as small as 0.2* micron by mechanical means

Utilizes Everpure 2SR-BW Feeder System for scale reduction up to one (1) year

Filtration media effectively inhibits the growth of bacteria on the filter media that can decrease product life

Features extra head for future expandability as water requirements increase

System provides two water outlets for separate water qualities, ideal for carbonated, ice and hot beverages

Backflush Tank included for backflushing as well as water storage for peak water demand

NSF/ANSI Standard 53 certified to reduce cysts such as *Italic* and *Giardia* by mechanical means

INSTALLATION TIPS

Choose a mounting location capable of safely supporting the full weight of the system when in operation.

Use 3/4" water line.

Fountain equipment connections are made to the outlet part of the system before the Everpure 2SR-BW Feeder System.

Coffee brewer and ice machine connections are made after the Everpure 2SR-BW Feeder System; a tee is required.

Install vertically with cartridges hanging down and allow 5" (12.7 cm) clearance below the cartridge for easy replacement.

Frame is designed to mount on 16" centers (wall studs).

OPERATION TIPS

Hollow fiber cartridge life is approximately three (3) years.

Replace quick-change cartridges on a regular 12-month preventative maintenance program.

Always flush the filter cartridges at time of installation and cartridge change.

Flush cartridges by running water through flushing valve for five (5) minutes at full flow.

Electrical outlet is required to operate the backflushing of the system.

SIZING

Rated Service Flow: 11.25 gpm (42.6 Lpm)

Capacity: Up to 150,000 gallons (567,812 L) or one (1) year.

*Validated by ISO 17025 accredited lab for 99.999% reduction of *Pseudomonas diminuta* following the ASTM F838-05 protocol for the validation of 0.2 µm sterilizing grade filters.

EVERPURE® ENDURANCE® SC HIGH FLOW TRIPLE 1.1 SYSTEM EV9437-41

SPECIFICATIONS

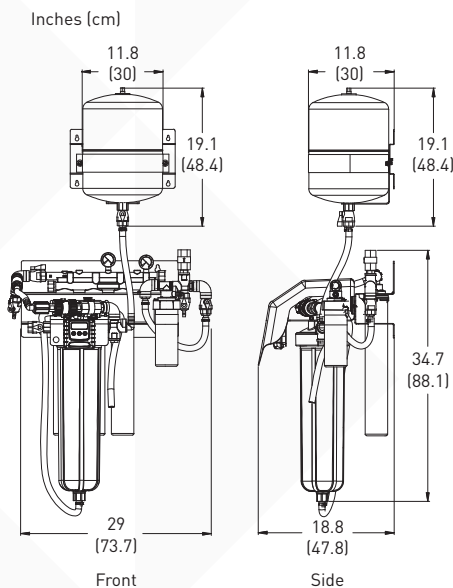

Overall System Dimensions

34.7" H x 29" W x 18.8" D
(88.1 cm x 73.7 cm x 47.8 cm)

Tank Dimensions

19.1" H x 11.8" W x 11.8" D
(48.4 cm x 30 cm x 30 cm)

Connections

Inlet: 3/4" (19 mm)
 Outlet: 3/4" FPT (19 mm)
 Backwash: 3/4" (19 mm) I.D. Tube
 2SR-BW Cartridge: 1/2" (13.6 mm) Barb
 Flush Ports: 3/8" (9.5 mm) Barb

Capacity

150,000 gallons (567,812 L) or one year

Rated Service Flow

11.25 gpm (42.6 Lpm)

Pressure Requirements

50 - 100 psi (3.5 - 6.9 bar), non-shock

Temperature

35 - 100°F (2 - 38°C)

Shipping Weight

67 lbs (30.4 kgs)

Operating Weight

111.5 lbs (50.6 kgs)

Electrical Connection

100 - 240 VAC / 50 - 60 Hz
 1.5 Amp (international plugs included)

Replacement Parts

Endurance SC Triple 1.1 Cartridge Kit:
 EV9628-81

Endurance SC UF Membrane
 Pretreatment Filter: EV9628-81

The contaminants or other substances removed or reduced by this drinking water system are not necessarily in your water. Do not use with water that is microbiologically unsafe or of unknown quality without adequate disinfection before or after the system. Systems certified for cyst reduction may be used with disinfected water that may contain filterable cysts.

Since the conditions under which our products may be used are beyond our control, we cannot accept any liability with respect to the improper installation, application and/or use of our products.

WARRANTY

Everpure water treatment systems by Pentair® (excluding replaceable elements) are covered by a limited warranty against defects in material and workmanship for a period of five years after date of purchase. Everpure replaceable elements (filter cartridges and water treatment cartridges) are covered by a limited warranty against defects in material and workmanship for a period of one year after date of purchase. See printed warranty for details. Pentair will provide a copy of the warranty upon request.



System Tested and Certified by NSF International against NSF/ANSI Standards 42 and 53 for the reduction of:

STANDARD NO. 42 —
 AESTHETIC EFFECTS

Bacteriostatic Effects
 Chemical Reduction
 Taste and Odor
 Chlorine

Mechanical Filtration
 Nominal Particulate Class I

STANDARD NO. 53 —
 HEALTH EFFECTS

Mechanical Filtration
 Turbidity
 Cyst

EPA Est. No. 002623-IL-002



WATER QUALITY SYSTEMS

EVERPURE-SHURFLO WORLD HEADQUARTERS, 1040 MUIRFIELD DRIVE, HANOVER PARK, IL 60133 USA • FOODSERVICE.PENTAIR.COM
 800.942.1153 (US ONLY) • 630.307.3000 MAIN • 630.307.3030 FAX • CSEVERPURE@PENTAIR.COM EMAIL

EVERPURE-SHURFLO AUSTRALIA, 1-21 MONASH DRIVE, DANDENONG SOUTH, VIC 3175 AUSTRALIA
 011.1300.576.190 TEL • 011.61.39.562.7237 FAX • AU.EVERPURE@PENTAIR.COM EMAIL

EVERPURE-SHURFLO CHINA, 21F CLOUD 9 PLAZA, NO 1118, SHANGHAI, 200052, CHINA
 86.21.3211.4588 TEL • 86.21.3211.4580 FAX • CHINA.WATER@PENTAIR.COM EMAIL

EVERPURE-SHURFLO INDIA, GREEN BOULEVARD, B-9/A, 7TH FLOOR - TOWER B SECTOR 62, NOIDA - 201301
 91.120.419.9444 TEL • 91.120.419.9400 FAX • INDIACUSTOMER@PENTAIR.COM EMAIL

EVERPURE-SHURFLO EUROPE, PENTAIR WATER BELGIUM BVBA, INDUSTRIEPARK WOLFSTEE, TOEKOMSTLAAN 30, B-2200 HERENTALS, BELGIUM
 +32.(0).14.283.504 TEL • +32.(0).14.283.505 FAX • SALES@EVERPURE-EUROPE.COM EMAIL

EVERPURE-SHURFLO JAPAN INC., HASHIMOTO MN BLDG. 7F, 3-25-1 HASHIMOTO, MIDORI-KU, SAGAMIHARA-SHI KANAGAWA 252-0143, JAPAN
 81.(0)42.775.3011 TEL • 81.(0)42.775.3015 FAX • INFO@EVERPURE.CO.JP EMAIL

EVERPURE-SHURFLO SOUTHEAST ASIA, 390 HAVELOCK ROAD, #04-01 KING'S CENTRE, SINGAPORE 169662
 65.6768.5800 TEL • 65.6737.5149 FAX • CSEVERPURE@PENTAIR.COM EMAIL

All Pentair trademarks and logos are owned by Pentair, Inc. or its affiliates. All other registered and unregistered trademarks and logos are the property of their respective owners. Because we are continuously improving our products and services, Pentair reserves the right to change specifications without prior notice. Pentair is an equal opportunity employer.