

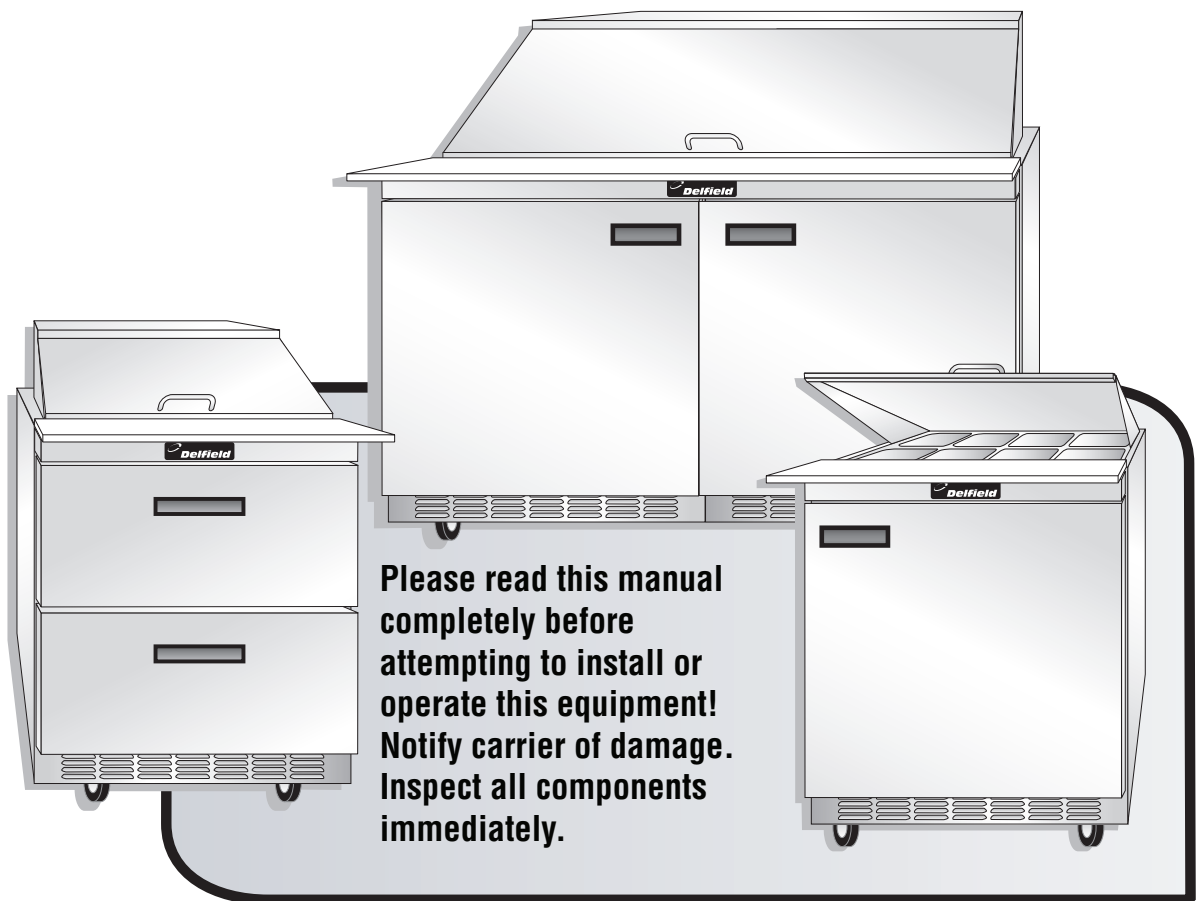

Installation & Operation Manual

4400 Series
Compact Refrigerators
4500 Series
Compact Freezers



**Please read this manual
completely before
attempting to install or
operate this equipment!
Notify carrier of damage.
Inspect all components
immediately.**

Delfield 980 S. Isabella Rd., Mt. Pleasant, MI 48858
(989) 773-7891 or (800) 733-8829 • Fax (989) 773-3210
www.delfield.com



February 2014

Important Warning And Safety Information



WARNING

Read This Manual Thoroughly Before Operating, Installing, Or Performing Maintenance On The Equipment.



WARNING

Failure To Follow Instructions In This Manual Can Cause Property Damage, Injury Or Death.



WARNING

Do Not Store Or Use Gasoline Or Other Flammable Vapors Or Liquids In The Vicinity Of This Or Any Other Appliance.



WARNING

Unless All Cover And Access Panels Are In Place And Properly Secured, Do Not Operate This Equipment.



WARNING

This Appliance Is Not Intended For Use By Persons Who Lack Experience Or Knowledge, Unless They Have Been Given Supervision Or Instruction Concerning Use Of The Appliance By A Person Responsible For Their Safety.



WARNING

This Appliance Is Not To Be Played With.



WARNING

Do Not Clean With Water Jet.



WARNING

Do Not Use Electrical Appliances Inside The Food Storage Compartment Of This Appliance.



CAUTION

Observe the following:

- Minimum clearances must be maintained from all walls and combustible materials.
- Keep the equipment area free and clear of combustible material.
- Allow adequate clearance for air openings.
- Operate equipment only on the type of electricity indicated on the specification plate.
- Unplug the unit before making any repairs.
- Retain this manual for future reference.

Contents

Receiving And Inspecting The Equipment	3
Introduction	4
Warranty Information.....	4
Regulatory Certifications	4
Specifications.....	5-12
Installation	13-14
Location	13
Inside Cabinet	13
Outside Cabinet.....	13
Leveling	13
Stabilizing	13
Plumbing	13
Electrical Connection.....	13
Cutting Board Bracket Mounting.....	14
Shelf Installation Instructions	14
2-Position Pan Rails Installation Instructions	14
Operation	15-16
Refrigeration Temperature Control.....	16
Freezer Temperature Control.....	17
Maintenance.....	18-19
Stainless Care And Cleaning	18
Condenser Coil Cleaning	18
Gasket.....	18
Doors/hinges	19
Drain	19
Drawer Maintenance	19
Wiring Diagram.....	20-22
Standard Labor Guidelines.....	23

Receiving And Inspecting The Equipment

Even though most equipment is shipped crated, care should be taken during unloading so the equipment is not damaged while being moved into the building.

1. Visually inspect the exterior of the package on skid or container. Any damage should be noted and reported to the delivering carrier immediately.
2. If damaged, open and inspect the contents with the carrier.
3. In the event that the exterior is not damaged, yet upon opening, there is concealed damage to the equipment notify the carrier. Notification should be made verbally as well as in written form.
4. Request an inspection of the concealed equipment. This should be done within 10 days from receipt of the equipment.
5. Check the lower portion of the unit to be sure legs or casters are not bent.
6. Also open the compressor compartment housing and visually inspect the refrigeration package. Be sure lines are secure and base is still intact.
7. Freight carriers can supply the necessary forms upon request.
8. Retain all crating material until an inspection has been made or waived.
9. Do not use forklift or pallet jack to move this equipment once it is removed from the pallet. Doing so may cause equipment damage and void warranty.

Uncrating the Equipment

First cut and remove the banding from around the crate. Remove the front of the crate material, use of some tools will be required. If the unit is on legs remove the top of the crate as well and lift the unit off the skid. If the unit is on casters it can be "rolled" off the skid.

Introduction

All cabinets have stainless steel exteriors and ABS interiors. Door gaskets are magnetic and mount to the door, snapping in place and are removable without tools.

Serial Number Location

The serial tag is located on the left upper sidewall inside the cabinet.

Always have the serial number of your cabinet available when calling for parts or service. A complete list of authorized Delfield parts depots is available on our website at www.delfield.com.

This manual covers standard cabinets only. If you have a custom cabinet, consult the customer service department at (800) 733-8829.

©2014 The Delfield Company. All rights reserved. Reproduction without written permission is prohibited. "Delfield" is a registered trademark of The Delfield Company.

Warranty Information

Visit http://www.delfield.com/minisite/service/warranty_info to:

- Register your product for warranty.
- Verify warranty information.
- View and download a copy of your warranty.

Regulatory Certifications

Models are certified by:



National Sanitation Foundation (NSF)



Underwriters Laboratories (UL)

Underwriters Laboratories of Canada (ULC)

Specifications

Undercounter Refrigerators - Depth 31.50" (80cm), Work Height 34.25" (87cm)

<i>Model</i>	<i>Description</i>	<i>L</i>	<i>Volume Ft³</i>	<i>Shelves Ft²</i>	<i>1/6 Pan Capacity</i>	<i>H.P.</i>	<i>Refr. Charge (oz)</i>	<i>Amp</i>	<i>NEMA Plug</i>	<i>Ship Weight (lbs/kg)</i>
UC4427N	one door	27" (69cm)	8.20	3.17	—	1/5	7.0	3.9	5-15P	223/101
UCD4427N	two drawer	27" (69cm)	8.20	—	—	1/5	7.0	3.9	5-15P	245/111
UC4432N	one door	32" (81cm)	10.10	3.88	—	1/5	7.0	3.9	5-15P	245/111
UCD4432N	two drawer	32" (81cm)	10.10	—	—	1/5	7.0	3.9	5-15P	293/133
UC4448N	two door	48" (122cm)	16.00	5.48	—	1/5	7.0	3.9	5-15P	316/143
UCD4448N	four drawer	48" (122cm)	16.00	—	—	1/5	7.0	3.9	5-15P	398/181
UC4460N	two door	60" (152cm)	20.20	7.19	—	1/5	7.0	3.9	5-15P	411/186
UCD4460N	four drawer	60" (152cm)	20.20	—	—	1/5	7.0	3.9	5-15P	495/225
UC4464N	two door	64" (163cm)	21.60	7.76	—	1/5	7.0	3.9	5-15P	421/191
UCD4464N	four drawer	64" (163cm)	21.60	—	—	1/5	7.0	3.9	5-15P	522/237
UC4472N	three door	72" (183cm)	24.80	8.22	—	1/5	7.0	3.9	5-15P	461/209
UCD4472N	six drawer	72" (183cm)	24.80	—	—	1/5	7.0	3.9	5-15P	545/247

Specifications, continued

Flat Top & Work Top Refrigerator Bases - Depth 31.50" (80cm), Work Height 36.00" (91cm)

<i>Model</i>	<i>Description</i>	<i>L</i>	<i>Volume Ft³</i>	<i>Shelves Ft²</i>	<i>1/6 Pan Capacity</i>	<i>H.P.</i>	<i>Refg. Charge (oz)</i>	<i>Amp</i>	<i>NEMA Plug</i>	<i>Ship Weight (lbs/kg)</i>
4427N	one door	27" (69cm)	8.20	3.17	—	1/5	7.0	3.9	5-15P	223/101
D4427N	two drawer	27" (69cm)	8.20	—	—	1/5	7.0	3.9	5-15P	245/111
ST4427N	one door	27" (69cm)	8.20	3.17	—	1/5	7.0	3.9	5-15P	223/101
STD4427N	two drawer	27" (69cm)	8.20	—	—	1/5	7.0	3.9	5-15P	245/111
4432N	one door	32" (81cm)	10.10	3.88	—	1/5	7.0	3.9	5-15P	245/111
D4432N	two drawer	32" (81cm)	10.10	—	—	1/5	7.0	3.9	5-15P	293/133
ST4432N	one door	32" (81cm)	10.10	3.88	—	1/5	7.0	3.9	5-15P	245/111
STD4432N	two drawer	32" (81cm)	10.10	—	—	1/5	7.0	3.9	5-15P	293/133
4448N	two door	48" (122cm)	16.00	5.48	—	1/5	7.0	3.9	5-15P	316/143
D4448N	four drawer	48" (122cm)	16.00	—	—	1/5	7.0	3.9	5-15P	398/181
ST4448N	two door	48" (122cm)	16.00	5.48	—	1/5	7.0	3.9	5-15P	316/143
STD4448N	four drawer	48" (122cm)	16.00	—	—	1/5	7.0	3.9	5-15P	398/181
4460N	two door	60" (152cm)	20.20	7.19	—	1/5	7.0	3.9	5-15P	411/186
D4460N	four drawer	60" (152cm)	20.20	—	—	1/5	7.0	3.9	5-15P	495/225
ST4460N	two door	60" (152cm)	20.20	7.19	—	1/5	7.0	3.9	5-15P	411/186
STD4460N	four drawer	60" (152cm)	20.20	—	—	1/5	7.0	3.9	5-15P	495/225
4464N	two door	64" (163cm)	21.60	7.76	—	1/5	7.0	3.9	5-15P	421/191
D4464N	four drawer	64" (163cm)	21.60	—	—	1/5	7.0	3.9	5-15P	522/237
ST4464N	two door	64" (163cm)	21.60	7.76	—	1/5	7.0	3.9	5-15P	421/191
STD4464N	four drawer	64" (163cm)	21.60	—	—	1/5	7.0	3.9	5-15P	522/237
4472N	three door	72" (183cm)	24.80	8.22	—	1/5	7.0	3.9	5-15P	461/209
D4472N	six drawer	72" (183cm)	24.80	—	—	1/5	7.0	3.9	5-15P	545/247
ST4472N	three door	72" (183cm)	24.80	8.22	—	1/5	7.0	3.9	5-15P	461/209
STD4472N	six drawer	72" (183cm)	24.80	—	—	1/5	7.0	3.9	5-15P	545/247

ST prefix models have a 4" stainless steel backsplash.

Specifications, continued

Salad Top Refrigerator Bases - Depth 31.50" (80cm), Work Height 36.00" (91 cm)

<i>Model</i>	<i>Description</i>	<i>L</i>	<i>Volume Ft³</i>	<i>Shelves Ft²</i>	<i>1/6 Pan Capacity</i>	<i>H.P.</i>	<i>Refr. Charge (oz)</i>	<i>Amp</i>	<i>NEMA Plug</i>	<i>Ship Weight (lbs/kg)</i>
4427N-6	one door	27" (69cm)	8.20	3.17	6	1/5	9	7.2	5-15P	223/101
D4427N-6	two drawer	27" (69cm)	8.20	—	6	1/5	9	7.2	5-15P	245/111
4427N-8	one door	27" (69cm)	8.20	3.17	8	1/5	9	7.2	5-15P	240/109
D4427N-8	two drawers	27" (69cm)	8.20	—	8	1/5	9	7.2	5-15P	240/109
ST4427N-8	one door	27" (69cm)	8.20	3.17	8	1/5	9	7.2	5-15P	240/109
STD4427N-8	two drawers	27" (69cm)	8.20	—	8	1/5	9	7.2	5-15P	240/109
4448N-8	two door	48" (122cm)	16.00	5.48	8	1/5	10	7.2	5-15P	316/143
D4448N-8	four drawer	48" (122cm)	16.00	—	8	1/5	10	7.2	5-15P	398/181
4448N-12	two door	48" (122cm)	16.00	5.48	12	1/5	10	7.2	5-15P	316/143
D4448N-12	four drawers	48" (122cm)	16.00	—	12	1/5	10	7.2	5-15P	398/181
ST4448N-8	two door	48" (122cm)	16.00	5.48	8	1/5	10	7.2	5-15P	316/143
STD4448N-8	four drawers	48" (122cm)	16.00	—	8	1/5	10	7.2	5-15P	398/181
4460N-8	two door	60" (152cm)	20.20	7.19	8	1/2	11	12	5-15P	411/186
D4460N-8	four drawer	60" (152cm)	20.20	—	8	1/2	11	12	5-15P	495/225
4460N-12	two door	60" (152cm)	20.20	7.19	12	1/2	11	12	5-15P	411/186
D4460N-12	four drawer	60" (152cm)	20.20	—	12	1/2	11	12	5-15P	495/225
ST4460N-8	two door	60" (152cm)	20.20	7.19	8	1/2	11	12	5-15P	411/186
STD4460N-8	four drawer	60" (152cm)	20.20	—	8	1/2	11	12	5-15P	495/225
4464N-8	two door	64" (163cm)	21.60	7.76	8	1/2	11	12	5-15P	421/191
D4464N-8	four drawer	64" (163cm)	21.60	—	8	1/2	11	12	5-15P	522/237
4464N-12	two door	64" (163cm)	21.60	7.76	12	1/2	11	12	5-15P	421/191
D4464N-12	four drawer	64" (163cm)	21.60	—	12	1/2	11	12	5-15P	522/237
4464N-16	two door	64" (163cm)	21.60	7.76	16	1/2	11	12	5-15P	421/191
D4464N-16	four drawer	64" (163cm)	21.60	—	16	1/2	11	12	5-15P	522/237
ST4464N-8	two door	64" (163cm)	21.60	7.76	8	1/2	11	12	5-15P	421/191
STD4464N-8	four drawer	64" (163cm)	21.60	—	8	1/2	11	12	5-15P	522/237
ST4464N-12	two door	64" (163cm)	21.60	7.76	12	1/2	11	12	5-15P	421/191
STD4464N-12	four drawer	64" (163cm)	21.60	—	12	1/2	11	12	5-15P	522/237
4472N-12	three door	72" (183cm)	24.80	8.22	12	1/2	11	12	5-15P	461/209
D4472N-12	six drawer	72" (183cm)	24.80	—	12	1/2	11	12	5-15P	545/247
4472N-18	three door	72" (183cm)	24.80	8.22	18	1/2	11	12	5-15P	461/209
D4472N-18	six drawer	72" (183cm)	24.80	—	18	1/2	11	12	5-15P	545/247
ST4472N-12	three door	72" (183cm)	24.80	8.22	12	1/2	11	12	5-15P	461/209
STD4472N-12	six drawer	72" (183cm)	24.80	—	12	1/2	11	12	5-15P	545/247

ST prefix models have a 4" stainless steel backsplash.

Specifications, continued

Mega Top Refrigerated Front Breathers - Depth 31.50" (80cm), Work Height 36.00" (91cm)

<i>Model</i>	<i>Description</i>	<i>L</i>	<i>Volume Ft³</i>	<i>Shelves Ft²</i>	<i>1/6 Pan Capacity</i>	<i>H.P.</i>	<i>Refrg. Charge (oz)</i>	<i>Amp</i>	<i>NEMA Plug</i>	<i>Ship Weight (lbs/kg)</i>
4427N-9M	one door	27" (69cm)	8.20	3.17	9	1/5	9	7.2	5-15P	223/101
D4427N-9M	two drawer	27" (69cm)	8.20	—	9	1/5	9	7.2	5-15P	245/111
4427N-12M	one door	27" (69cm)	8.20	3.17	12	1/5	9	7.2	5-15P	223/101
D4427N-12M	two drawer	27" (69cm)	8.20	—	12	1/5	9	7.2	5-15P	245/111
ST4427N-12M	one door	27" (69cm)	8.20	3.17	12	1/5	9	7.2	5-15P	223/101
STD4427N-12M	two drawer	27" (69cm)	8.20	—	12	1/5	9	7.2	5-15P	245/111
4432N-12M	one door	32" (81cm)	10.10	3.88	12	1/5	9	7.2	5-15P	245/111
D4432N-12M	two drawer	32" (81cm)	10.10	—	12	1/5	9	7.2	5-15P	293/133
4448N-18M	two door	48" (122cm)	16.00	5.48	18	1/5	10	7.2	5-15P	316/143
D4448N-18M	four drawer	48" (122cm)	16.00	—	18	1/5	10	7.2	5-15P	398/181
4460N-12M	two door	60" (152cm)	20.20	7.19	12	1/2	11	12	5-15P	411/186
D4460N-12M	four drawer	60" (152cm)	20.20	—	12	1/2	11	12	5-15P	495/225
4460N-18M	two door	60" (152cm)	20.20	7.19	18	1/2	11	12	5-15P	411/186
D4460N-18M	four drawer	60" (152cm)	20.20	—	18	1/2	11	12	5-15P	495/225
4460N-24M	two door	60" (152cm)	20.20	7.19	24	1/2	11	12	5-15P	411/186
D4460N-24M	four drawer	60" (152cm)	20.20	—	24	1/2	11	12	5-15P	495/225
ST4460N-12M	two door	60" (152cm)	20.20	7.19	12	1/2	11	12	5-15P	411/186
STD4460N-12M	four drawer	60" (152cm)	20.20	—	12	1/2	11	12	5-15P	495/225
ST4460N-18M	two door	60" (152cm)	20.20	7.19	18	1/2	11	12	5-15P	411/186
STD4460N-18M	four drawer	60" (152cm)	20.20	—	18	1/2	11	12	5-15P	495/225
4464N-12M	two door	64" (163cm)	21.60	7.76	12	1/2	11	12	5-15P	421/191
D4464N-12M	four drawer	64" (163cm)	21.60	—	12	1/2	11	12	5-15P	522/237
4464N-18M	two door	64" (163cm)	21.60	7.76	18	1/2	11	12	5-15P	421/191
D4464N-18M	four drawer	64" (163cm)	21.60	—	18	1/2	11	12	5-15P	522/237
4464N-24M	two door	64" (163cm)	21.60	7.76	24	1/2	11	12	5-15P	421/191
D4464N-24M	four drawer	64" (163cm)	21.60	—	24	1/2	11	12	5-15P	522/237
ST4464N-12M	two door	64" (163cm)	21.60	7.76	12	1/2	11	12	5-15P	421/191
STD4464N-12M	four drawer	64" (163cm)	21.60	—	12	1/2	11	12	5-15P	522/237
ST4464N-18M	two door	64" (163cm)	21.60	7.76	18	1/2	11	12	5-15P	421/191
STD4464N-18M	four drawer	64" (163cm)	21.60	—	18	1/2	11	12	5-15P	522/237

Specifications, continued

<i>Model</i>	<i>Description</i>	<i>L</i>	<i>Volume Ft³</i>	<i>Shelves Ft²</i>	<i>1/6 Pan Capacity</i>	<i>H.P.</i>	<i>Refr. Charge (oz)</i>	<i>Amp</i>	<i>NEMA Plug</i>	<i>Ship Weight (lbs/kg)</i>
4472N-18M	three door	72" (183cm)	24.80	8.22	18	1/2	11	12	5-15P	461/209
D4472N-18M	six drawer	72" (183cm)	24.80	—	18	1/2	11	12	5-15P	545/247
4472N-24M	three door	72" (183cm)	24.80	8.22	24	1/2	11	12	5-15P	461/209
D4472N-24M	six drawer	72" (183cm)	24.80	—	24	1/2	11	12	5-15P	545/247
4472N-30M	three door	72" (183cm)	24.80	8.22	30	1/2	11	12	5-15P	461/209
D4472N-30M	six drawer	72" (183cm)	24.80	—	30	1/2	11	12	5-15P	545/247
ST4472N-18M	three door	72" (183cm)	24.80	8.22	18	1/2	11	12	5-15P	461/209
STD4472N-18M	six drawer	72" (183cm)	24.80	—	18	1/2	11	12	5-15P	545/247
ST4472N-24M	three door	72" (183cm)	24.80	8.22	24	1/2	11	12	5-15P	461/209
STD4472N-24M	six drawer	72" (183cm)	24.80	—	24	1/2	11	12	5-15P	545/247

ST prefix models have a 4" stainless steel backsplash.

Specifications, continued

Reduced Work Height Salad Top Refrigerated Front Breathers - Depth 31.50" (80cm), Work Height 34.25" (87cm)

<i>Model</i>	<i>Description</i>	<i>L</i>	<i>Volume Ft³</i>	<i>Shelves Ft²</i>	<i>1/6 Pan Capacity</i>	<i>H.P.</i>	<i>Refrg. Charge (oz)</i>	<i>Amp</i>	<i>NEMA Plug</i>	<i>Ship Weight (lbs/kg)</i>
UC4427N-6	one door	27" (69cm)	8.20	3.17	6	1/5	9	7.2	5-15P	223/101
UCD4427N-6	two drawer	27" (69cm)	8.20	—	6	1/5	9	7.2	5-15P	245/111
UC4448N-8	two door	48" (122cm)	16.00	5.48	8	1/5	10	7.2	5-15P	316/143
UCD4448N-8	four drawer	48" (122cm)	16.00	—	8	1/5	10	7.2	5-15P	398/181
UC4448N-12	two door	48" (122cm)	16.00	5.48	12	1/5	10	7.2	5-15P	316/143
UCD4448N-12	four drawer	48" (122cm)	16.00	—	12	1/5	10	7.2	5-15P	398/181
UC4460N-8	two door	60" (152cm)	20.20	7.19	8	1/2	11	12	5-15P	411/186
UCD4460N-8	four drawer	60" (152cm)	20.20	—	8	1/2	11	12	5-15P	495/225
UC4460N-12	two door	60" (152cm)	20.20	7.19	12	1/2	11	12	5-15P	411/186
UCD4460N-12	four drawer	60" (152cm)	20.20	—	12	1/2	11	12	5-15P	495/225
UC4464N-8	two door	64" (163cm)	21.60	7.76	8	1/2	11	12	5-15P	421/191
UCD4464N-8	four drawer	64" (163cm)	21.60	—	8	1/2	11	12	5-15P	522/237
UC4464N-12	two door	64" (163cm)	21.60	7.76	12	1/2	11	12	5-15P	421/191
UCD4464N-12	four drawer	64" (163cm)	21.60	—	12	1/2	11	12	5-15P	522/237
UC4464N-16	two door	64" (163cm)	21.60	7.76	16	1/2	11	12	5-15P	421/191
UCD4464N-16	four drawer	64" (163cm)	21.60	—	16	1/2	11	12	5-15P	522/237
UC4472N-12	three door	72" (183cm)	24.80	8.22	12	1/2	11	12	5-15P	461/209
UCD4472N-12	six drawer	72" (183cm)	24.80	—	12	1/2	11	12	5-15P	545/247
UC4472N-18	three door	72" (183cm)	24.80	8.22	18	1/2	11	12	5-15P	461/209
UCD4472N-18	six drawer	72" (183cm)	24.80	—	18	1/2	11	12	5-15P	545/247

Specifications, continued

Reduced Work Height Mega Top Refrigerated Front Breathers - Depth 31.50" (80cm), Work Height 34.25" (87cm)

<i>Model</i>	<i>Description</i>	<i>L</i>	<i>Volume Ft³</i>	<i>Shelves Ft²</i>	<i>1/6 Pan Capacity</i>	<i>H.P.</i>	<i>Refr. Charge (oz)</i>	<i>Amp</i>	<i>NEMA Plug</i>	<i>Ship Weight (lbs/kg)</i>
UC4427N-9M	one door	27" (69cm)	8.20	3.17	9	1/5	9	7.2	5-15P	223/101
UCD4427N-9M	two drawer	27" (69cm)	8.20	—	9	1/5	9	7.2	5-15P	245/111
UC4427N-12M	one door	27" (69cm)	8.20	3.17	12	1/5	9	7.2	5-15P	223/101
UCD4427N-12M	two drawer	27" (69cm)	8.20	—	12	1/5	9	7.2	5-15P	245/111
UC4432N-12M	one door	32" (81cm)	10.10	3.88	12	1/5	9	7.2	5-15P	245/111
UCD4432N-12M	two drawer	32" (81cm)	10.10	—	12	1/5	9	7.2	5-15P	293/133
UC4448N-18M	two door	48" (122cm)	16.00	5.48	18	1/5	10	7.2	5-15P	316/143
UCD4448N-18M	four drawer	48" (122cm)	16.00	—	18	1/5	10	7.2	5-15P	398/181
UC4460N-12M	two door	60" (152cm)	20.20	7.19	12	1/2	11	12	5-15P	411/186
UCD4460N-12M	four drawer	60" (152cm)	20.20	—	12	1/2	11	12	5-15P	495/225
UC4460N-18M	two door	60" (152cm)	20.20	7.19	18	1/2	11	12	5-15P	411/186
UCD4460N-18M	four drawer	60" (152cm)	20.20	—	18	1/2	11	12	5-15P	495/225
UC4460N-24M	two door	60" (152cm)	20.20	7.19	24	1/2	11	12	5-15P	411/186
UCD4460N-24M	four drawer	60" (152cm)	20.20	—	24	1/2	11	12	5-15P	495/225
UC4464N-12M	two door	64" (163cm)	21.60	7.76	12	1/2	11	12	5-15P	421/191
UCD4464N-12M	four drawer	64" (163cm)	21.60	—	12	1/2	11	12	5-15P	522/237
UC4464N-18M	two door	64" (163cm)	21.60	7.76	18	1/2	11	12	5-15P	421/191
UCD4464N-18M	four drawer	64" (163cm)	21.60	—	18	1/2	11	12	5-15P	522/237
UC4464N-24M	two door	64" (163cm)	21.60	7.76	24	1/2	11	12	5-15P	421/191
UCD4464N-24M	four drawer	64" (163cm)	21.60	—	24	1/2	11	12	5-15P	522/237
UC4472N-18M	three door	72" (183cm)	24.80	8.22	18	1/2	11	12	5-15P	461/209
UCD4472N-18M	six drawer	72" (183cm)	24.80	—	18	1/2	11	12	5-15P	545/247
UC4472N-24M	three door	72" (183cm)	24.80	8.22	24	1/2	11	12	5-15P	461/209
UCD4472N-24M	six drawer	72" (183cm)	24.80	—	24	1/2	11	12	5-15P	545/247
UC4472N-30M	three door	72" (183cm)	24.80	8.22	30	1/2	11	12	5-15P	461/209
UCD4472N-30M	six drawer	72" (183cm)	24.80	—	30	1/2	11	12	5-15P	545/247

Specifications, continued

Flat Top Freezer Bases - Depth 31.50" (80cm), Work Height 36.00" (91cm)

<i>Model</i>	<i>Description</i>	<i>L</i>	<i>Volume Ft.³</i>	<i>Shelves Ft.²</i>	<i>1/6 Pan Capacity</i>	<i>H.P.</i>	<i>Refg. Charge (oz)</i>	<i>Amp</i>	<i>NEMA Plug</i>	<i>Ship Weight (lbs/kg)</i>
4532N	one door	32" (81cm)	8.80	3.88	—	1/5	9.0	9.5	5-15P	245/111
D4532N	two drawer	32" (81cm)	8.80	—	—	1/3	9.0	9.5	5-15P	293/133/
ST4532N	one door	32" (81cm)	8.80	3.88	—	1/5	9.0	9.5	5-15P	245/111
STD4532N	two drawer	32" (81cm)	8.80	—	—	1/3	9.0	9.5	5-15P	293/133
4560N	two door	60" (152cm)	16.90	7.19	—	1/3	14.0	12.0	5-15P	411/186
ST4560N	two door	60" (152cm)	16.90	7.19	—	1/3	14.0	12.0	5-15P	411/186

ST prefix models have a 4" stainless steel backsplash.

Undercounter Freezers - Depth 31.50" (80cm), Work Height 34.25" (87cm)

<i>Model</i>	<i>Description</i>	<i>L</i>	<i>Volume Ft.³</i>	<i>Shelves Ft.²</i>	<i>1/6 Pan Capacity</i>	<i>H.P.</i>	<i>Refg. Charge (oz)</i>	<i>Amp</i>	<i>NEMA Plug</i>	<i>Ship Weight (lbs/kg)</i>
UC4532N	one door	32" (81cm)	8.80	3.88	—	1/5	9.0	9.5	5-15P	245/111
UCD4532N	two drawer	32" (81cm)	8.80	—	—	1/3	9.0	9.5	5-15P	293/133
UC4560N	two door	60" (152cm)	16.90	7.19	—	1/3	14.0	12.0	5-15P	411/186

Installation

Location

Cabinets represented in this manual are intended for indoor use only. Be sure the location chosen has a floor strong enough to support the total weight of the cabinet and contents. Reinforce the floor as necessary to provide for maximum loading.

The location should be selected so that power cords can be connected without any extensions.

For the most efficient operation, be sure to provide good air circulation inside and outside the cabinet. Avoid hot corners and locations near stoves and ovens.

Inside Cabinet

Do not pack refrigerator so full that air cannot circulate.

Outside Cabinet

4400 Series equipment door and drawer models

These cabinets have Delfield's "front-breathing" design. They may be installed flush against a wall or built into a counter as required.

The louver at the floor level must be kept completely clear of any obstructions. Proper operation of these models is dependent on air being able to flow freely through the front louver. The louver at the back of the cabinet is not necessary for proper operation, but any air flow through it is beneficial.



Any restriction of the proper air flow outlined above, total or partial, will void the warranty on the cabinet.

Leveling

A level cabinet will perform better because the drain pan will drain properly, the drawers or doors will line up with the frames and the cabinet will not be subject to undue strain.



Never stand on the unit or its drawers! Doing so may result in bodily injury. They are not designed to hold the weight of a person and will collapse if misused in this manner.

Stabilizing

All models are supplied standard on casters for your convenience, for ease of cleaning underneath and for mobility.



The cabinet must be installed in a stable condition with the front wheels locked. Locking the front casters after installation is the owner's and operator's responsibility.

Plumbing

Self-contained models are standard with a condensate evaporator. If, for some reason, a cabinet does not have a condensate evaporator, or the evaporator fails, the cabinets drain must have an outlet to an appropriate drainage area or container.



Moisture collecting from improper drainage can create a slippery surface on the floor and a hazard to employees. It is the owner's responsibility to provide a container or outlet for drainage.

Electrical Connection

A 6' (1.8 m) long grounded supply cord and three-pronged plug are provided with standard cabinets. Simply plug into a three-pronged wall outlet for proper grounding of the cabinet to begin operation. Do not use an adapter to connect to a two-pronged outlet. The three-pronged outlet provides a ground connection which must be used to prevent a shock hazard.



The wall outlet must be checked by a qualified electrician to be sure a proper ground is present and that the outlet provides the correct voltage and required amperage to match the rating plate. Any power cord that is frayed or damaged should be replaced. When disconnecting the cabinet from the power source, do not pull on the cord. Firmly grip the plug and remove from outlet.

The 5-15P plug shown below is used on the various 4400 Series models.

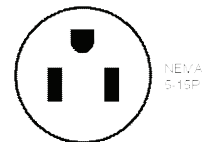

Refer to the amperage data list in SPECIFICATIONS, the serial tag, your local code or the National Electrical Code to be sure the cabinet is connected to the proper power source. A protected circuit of the correct voltage and amperage must be run for connection of the line cord, or permanent connection to the cabinet.

Power Switch

Salad and Mega top 4460, 4464, and 4472 models are equipped with a power disconnect switch located at the rear of the unit just below the thermostat control knob. Switch must be in the "on" position for the unit to operate.



The thermostat must be turned to OFF and the cabinet disconnected from the power source whenever performing service, maintenance functions or cleaning the refrigerated area.

Installation, continued

Cutting Board Bracket Mounting

1. Gather brackets, cutting board and screwdriver.
2. Open the door to install the center bracket.
3. Remove four screws from the nosing.
4. Place the bracket and secure with the four removed screws.



5. Remove two screws from one end.
6. Place the bracket and secure with the two removed screws.



7. Repeat at the other end.
8. Insert the cutting board into the brackets, back first. Lay it down with the holes over the alignment pins.

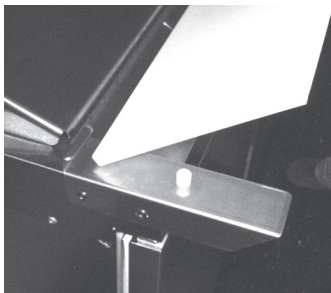

Bracket Adjustment

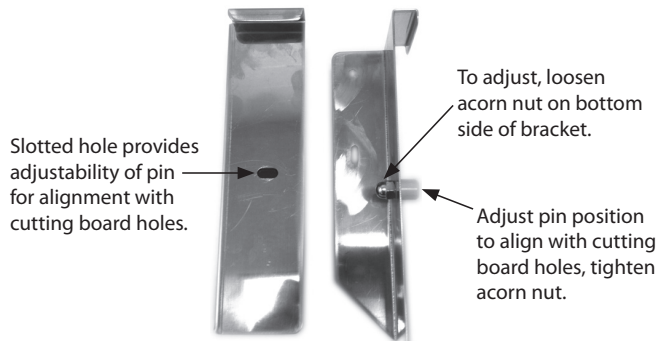

Shelf Installation Instructions

1. Notice the shelves have four alignment pins on the underside and a backstop on the top back.
2. Insert the shelves into the cabinet.

- The backstop should be at the top back.



- The alignment pins should be in front and back of the shelf supports.

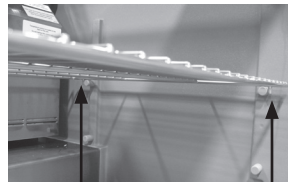

Changing Pan Height

If additional pan temperature cooling ability is desired, especially in higher ambient temperature conditions and/or if pan covers are open or off for extended time periods improved cooling of pans can usually be achieved by utilizing the lower position of the dual level pan guides.

When utilizing the lower position on a model with drawers, only 4" deep pans can be used in the top. When utilizing the lower position on a door model, 4" or 6" deep pans may be used.

1. Remove all pans, pan dividers, front and rear support bars.
2. Remove the upper side support brackets by pulling them up and off as shown below.
3. Reinstall all components removed in step one.

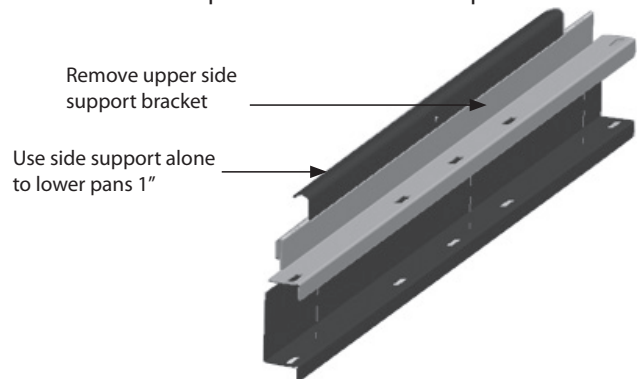

If the lower pan position is desired for models 4427N-8 or 4427N-12M, model specific brackets must be ordered. They will hold pans at the lower position and replace all other brackets.

Refrigerated Cabinet Operation

Power Switch

Salad and Mega top 4460, 4464, and 4472 models are equipped with a power disconnect switch located at the rear of the unit just below the thermostat control knob. Switch must be in the "on" position for the unit to operate.

Operation

After the cabinet is connected to the power source it will automatically begin operating. With the covers and doors closed, the temperature of the cabinet should reach 36°F to 40°F (2°C to 4°C) in about one hour. Temperature on salad top will maintain 33°F to 41°F (1°C to 4°C) with pans recessed 2.5" (6.5cm) at 86°F ambient room temperature for a period of four hours, meeting NSF-7 requirements. The temperature control on a flat top unit other than 4427 models is located on the back panel inside the refrigerator and can be adjusted to meet the current conditions. The temperature control on 4427 flat top and all salad top units is located in the rear of the unit, 14" to 16" above floor in access hole.

Temperature Control Instruction for Flat Top Units except 4427 Models

A thermostat located in the evaporator housing on the interior rear of the cabinet controls the temperature inside the box. The factory setting for the control is "4" and maintains about 38°F (3°C) inside the box. Set toward "1" for higher temperatures and set to a higher number for lower temperatures.

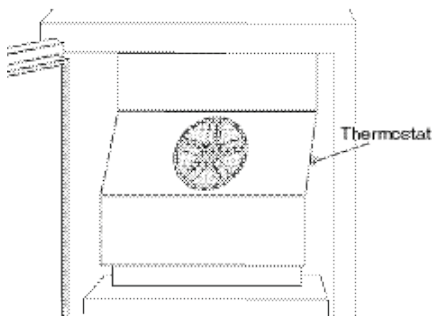

Flat Top Units except 4427 Models

Temperature Control Instruction for Salad Top Units and 4427 Flat Top Models

A thermostat located in rear of cabinet controls the temperature inside the box. The factory setting for the control is 4.5 and maintains about 34°F (1°C) to 36°F (2°C) inside the box. Set toward 1 for higher temperatures and set to a higher number for lower temperatures.

Evaporator Fan(s) Operation

Salad and mega top refrigerator units under 60" wide have one evaporator and one evaporator fan motor and blade. 60", 64" and 72" wide units have one large evaporator and two fan motors and blades. Both motors rotate in the same direction and both have identical fan blades.

Important Information on 4427 Solid Top Models:

The unit is Energy Star Version II compliant. During normal operation the evaporator fan pulses independently of the compressor as dictated by the Danfoss Controller as follows:

1. During the cooling mode, compressor and evaporator fan run simultaneously.
2. During the compressor off mode, evaporator fan pulses three minutes on and three minutes off.
3. During an actual defrost event other than the off-cycle defrost, compressor stays off but the evaporator fan runs continuously.

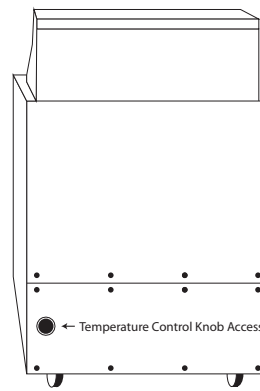

Salad Top Units and 4427 Flat Top Models



Cabinets with pans should be operated with pans in place. Operating the cabinet without all pans in place will lessen efficiency and may damage the cabinet.

Continuous opening and closing of the door will hamper the cabinet's ability to maintain optimum refrigeration temperature.

Top section is not intended for overnight storage. Product should be removed from pans. Pans can remain in cabinet while empty.

Refrigerated Cabinet Operation, continued

Defrosting of Flat Top Models Except 4427

Refrigerators defrost automatically with every cycle of the compressor. The water generated is routed to a pan on the rear of the cabinet and is evaporated by the heat given off by the compressor.

Defrosting of Salad Top, Mega Top and 4427 Flat Top Models

The electronic temperature controller monitors evaporator temperature and compressor run time to determine the proper time for a positive defrost cycle. A defrost cycle can occur as often as every 45 minutes under extremely heavy usage. When the controller enters the defrost mode the compressor is shut off and will remain off until the evaporator coil temperature exceeds 41°F or the controller reaches a time limit of 50 minutes. The defrost cycle can last from a minimum of 2 minutes to a maximum of 50 minutes.

Service Alert

During normal operation the evaporator fan may cycle and/or pulse independently of the compressor. Consult the service manual or contact Technical Support at 1-800-733-8829 if you are unsure of the proper function.

	Cooling Cycle				Defrost Cycle	
	Compressor On		Compressor Off		Compressor Off	
	Evap Fan On	Evap Fan Off	Evap Fan On	Evap Fan Off	Evap Fan On	Evap Fan Off
4400 Open Top	X		X		X	
4400 Solid Top	X		X		X	
4427 Solid Top	X		Cycles On 3-Min, Off 3-Min		X	

Freezer Cabinet Operation

The electronic temperature control constantly monitors box temperature as well as evaporator coil temperature to maintain consistent product temperatures.

At initial start-up or anytime power is disconnected, then reconnected to the unit, the control will delay all operations for a short time (up to 10 minutes.) While in this delay period, the control initializes the control parameters and confirms that the temperature sensors and circuits are operational.



NOTE

REGARDING FREEZERS: After initializing, the control will immediately enter a DEFROST mode. The compressor and condenser fan as well as the evaporator fan will remain off until initialization defrost is complete. This initial defrost cycle may take up to 15 minutes to complete, at which time the freezing cycle will begin.

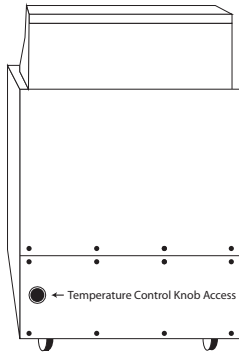

Freezers

The control is located in the rear of the cabinet. Freezers are factory set at mid-range to maintain about -3°F (-19°C) box temperature. To adjust for colder temperatures, turn the knob clockwise. For warmer temperatures, turn the knob counter-clockwise. Turn the knob fully counter-clockwise to turn the refrigeration system off. Never turn the knob more than 1 dial number and always allow 8 hours for temperature stabilization before making any additional adjustments.

Freezer cabinets with two evaporators have counter-rotating fans to ensure even airflow throughout the cabinet. The left evaporator has a CCW motor and a clear fan blade and the right evaporator has a CW motor and a black fan blade.

The evaporator fan(s) and condenser fan will cycle off and on with the compressor to conserve energy.

Freezer:

Whenever the freezer is plugged in, and the control has completed initializing including the initial defrost cycle. The temperature control will cycle the compressor and condenser fan motor and evaporator fan motor to maintain box temperature at the control setting.

Freezer Automatic Defrost

The control also monitors compressor total running time and will enter a defrost cycle after total compressor running time is greater than 4-hours since the last defrost cycle OR if evaporator coil temperature drops below -34°F (-37°C) (indicating excessive frost on the coil.)

When the control enters the defrost mode, it switches off the evaporator fan motor, compressor and condenser fan motor, and switches on the defrost heater to warm the evaporator coil. Thereby melting all frost accumulated during the previous refrigeration cycle. The control will continue the defrost cycle for a MINIMUM of 8 minutes and a MAXIMUM of 30 minutes depending on the amount of frost accumulated on the evaporator coil.

After the defrost cycle is complete, the control returns to a normal refrigeration cycle, however the evaporator fan motor will not switch on for 2 minutes AFTER the compressor and condenser fan motor have begun operating.

Freezer Manual Defrost

If a manual defrost is desired, simply unplug the unit for several seconds, then plug unit back in. This will cause the control to re-initialize and then enter a defrost cycle.

Service Alert

During normal operation the evaporator fan may cycle and/or pulse independently of the compressor. Consult the service manual or contact Technical Support at 1-800-733-8829 if you are unsure of the proper function.

	Cooling Cycle				Defrost Cycle	
	Compressor On		Compressor Off		Compressor Off	
	Evap Fan On	Evap Fan Off	Evap Fan On	Evap Fan Off	Evap Fan On	Evap Fan Off
4500 Freezer	X			X		X

Maintenance



The thermostat must be turned to OFF and the cabinet disconnected from the power source whenever performing service, maintenance functions or cleaning the refrigerated area.

Stainless Steel Care And Cleaning

To prevent discoloration or rust on stainless steel several important steps need to be taken. First, the properties of stainless steel need to be understood. Stainless steel contains 70-80% iron which will rust. It also contains 12-30% chromium which forms an invisible passive film over the steel's surface which acts as a shield against corrosion. As long as the protective layer is intact, the metal will not corrode and is still stainless. If the film is broken or contaminated, outside elements can begin to breakdown the steel and begin to form rust or other discoloration.



NEVER USE STEEL PADS, WIRE BRUSHES OR SCRAPERS!

Do not use an abrasive cleaner because it will scratch the stainless steel and plastic and can damage gaskets. Proper cleaning of stainless steel requires soft cloths or plastic scouring pads.

Cleaning solutions need to be alkaline based or non-chloride cleaners. Any cleaner containing chlorides will damage the protective film of the stainless steel. Chlorides are also commonly found in hard water, salts and household and industrial cleaners. If cleaners containing chlorides are used, be sure to rinse repeatedly and dry thoroughly upon completion.

Routine cleaning of the interior and exterior can be done with soap and warm water. Extreme stains or grease should be cleaned with a non-abrasive cleaner and plastic scrub pad. When cleaning the exterior, always rub with the grain of the stainless steel to avoid marring the finish. There are also stainless steel cleaners available which can restore and preserve the finish of the steel's protective layer.

Early signs of stainless steel breakdown can consist of small pits and cracks. If this has begun, clean thoroughly and start to apply stainless steel cleaners in an attempt to restore the passivity of the steel.



Never use an acid based cleaning solution! Many food products have an acidic content which can deteriorate the finish. Be sure to clean ALL food products from any stainless steel surface. Common items include, tomatoes, peppers and other vegetables.

CLEANING THE CONDENSER COIL

The condenser coil requires regular cleaning every 90 days (recommended). In some instances you may find a large amount of debris and dust or grease accumulated prior to the 90 day time frame. In these cases the condenser coil should be cleaned every 30 days.

If the build up on the coil consists of only light dust and debris the condenser coil can be cleaned with a simple brush. Heavier dust build up may require a vacuum or even compressed air to blow through the condenser coil.

If heavy grease is present there are de-greasing agents available for refrigeration use, and specifically for the condenser coils. The condenser coil may require using a de-greasing agent and then being blown through with compressed air. Follow the de-greasing agent manufacturer's instructions.

Failure to maintain a clean condenser coil can initially cause high temperatures and excessive run times. Continuous operation with dirty or clogged condenser coils can result in compressor failure. Neglecting the condenser coil cleaning procedures will void any warranties associated with the compressor or cost to replace the compressor.



Never use a high pressure water wash for this cleaning procedure as water can damage the electrical components located near or at the condenser coil.

In order to maintain proper refrigeration performance, the condenser fins must be cleaned of dust, dirt and grease regularly. It is recommended that this be done every three months. If conditions are such that the condenser is totally blocked in three months, the frequency of cleaning should be increased. Clean the condenser with a vacuum cleaner or stiff brush. If extremely dirty, a commercially available condenser cleaner may be required.

If your freezer seems to vibrate excessively when the compressor is running, loosen (but do not remove) the bolts on the compressor. Semi-hermetic models should be loosened before operating.

Gasket Maintenance

Gaskets require regular cleaning to prevent mold and mildew build up and also to maintain the elasticity of the gasket. Gasket cleaning can be done with the use of warm soapy water. Avoid full strength cleaning products on gaskets as this can cause them to become brittle and prevent proper seals. Also, never use sharp tools or knives to scrape or clean the gasket which could possibly tear the gasket and rip the bellows.

Gaskets can easily be replaced and do not require the use of tools or authorized service persons. The gaskets are "Dart"

Maintenance, continued

style and can be pulled out of the groove in the door and new gaskets can be "pressed" back into place.

Doors/Hinges

Over time and with heavy use the door hinges may become loose. If it is noticed that the door is beginning to sag, it may be necessary to tighten the screws that mount the hinge brackets to the frame of the cabinet. If the doors are loose or sagging, this can cause the hinge to pull out of the frame which may damage both the doors and the door hinges. In some cases this may require repair by a qualified service agent or maintenance personnel.

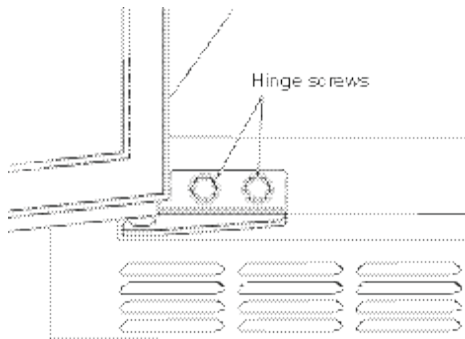

Drain Maintenance

Each cabinet has a drain located inside which removes the condensation from the evaporator coil and evaporates it at an external condensate evaporator pan. Each drain can become loose or disconnected from moving or bumping the drain. If you notice excessive water accumulation on the inside of the cabinet, be sure the drain tube is connected from the evaporator housing to the condensate evaporator drain pan. If water has collected underneath the cabinet, check the condensate evaporator drain tube to be sure it is still located inside the drain pan. Leveling the cabinet is important as it is designed to drain properly when on a level surface. If your floor is not level this can also cause drain problems. Be sure all drain lines are free of obstructions. Typically, food product is found blocking drain lines causing water to back up and overflow the drain pans.

Drawer Maintenance

Drawer Assembly Cleaning

The drawer assembly is designed to be cleaned easily. Both drawer and tracks are removable without tools. The drawer tracks are dishwasher safe or can be cleaned in a sink with detergents and a soft bristle brush. Drawers and tracks should be cleaned on a weekly basis.

Remove Drawers

Pull the drawer box out until it stops. Lift up on the drawer front and pull the drawer box completely out. Using a soft bristle brush,

clean the track on the bottom of the drawer box. When finished, it should be wiped clean of all food and debris.

Tracks

The drawer box assembly must be removed. Pull the drawer tracks out until they hit a stop. Locate blue safety clips towards the back of each drawer track. Blue safety clips have a tab on the top. Push the tab back until it clicks. Lift up and pull the drawer

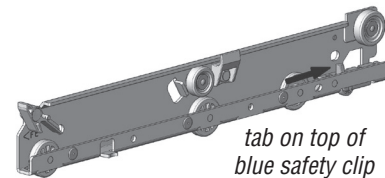

tracks all the way out of the drawer cage. The drawer tracks are dishwasher safe or can be cleaned in a sink with detergents and a soft bristle brush. Drawers and tracks should be cleaned

on a weekly basis. Using a soft bristle brush, wash the track making sure each roller is thoroughly cleaned. The drawer cage should be cleaned with a soft bristle brush, removing any food and debris gathered on the bottom ledge. Once it's cleaned thoroughly with a soft bristle brush, wipe remaining debris clean with a soft towel.

Reassembly

Push the drawer tracks into the drawer cage. The blue safety clip must remain pushed towards the back. Lift up and slide the drawer track all the way into the drawer cage. The blue safety clip will lock in place automatically. Once all tracks are replaced, insert the drawer box. Rest the drawer box bottom track on the front track roller. Then push the drawer back in place SLOWLY. When the drawer box is about half way in you will hit a STOP. You must lift the front of the drawer up approximately 1/2" (1.3cm) to continue inward. Clean tracks as often as possible. The cleaner the tracks are the better they will operate.

Fluorescent Light Bulb Replacement

Delfield recommends that fluorescent light bulbs be recycled rather than disposed of.

Wiring Diagram, 4427 Flat Top Refrigerator

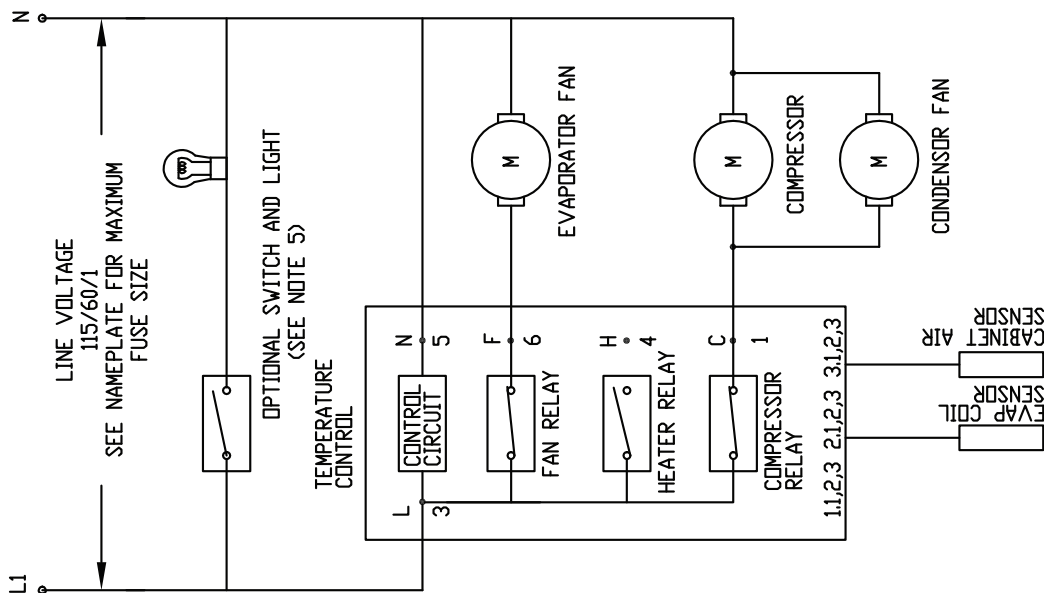
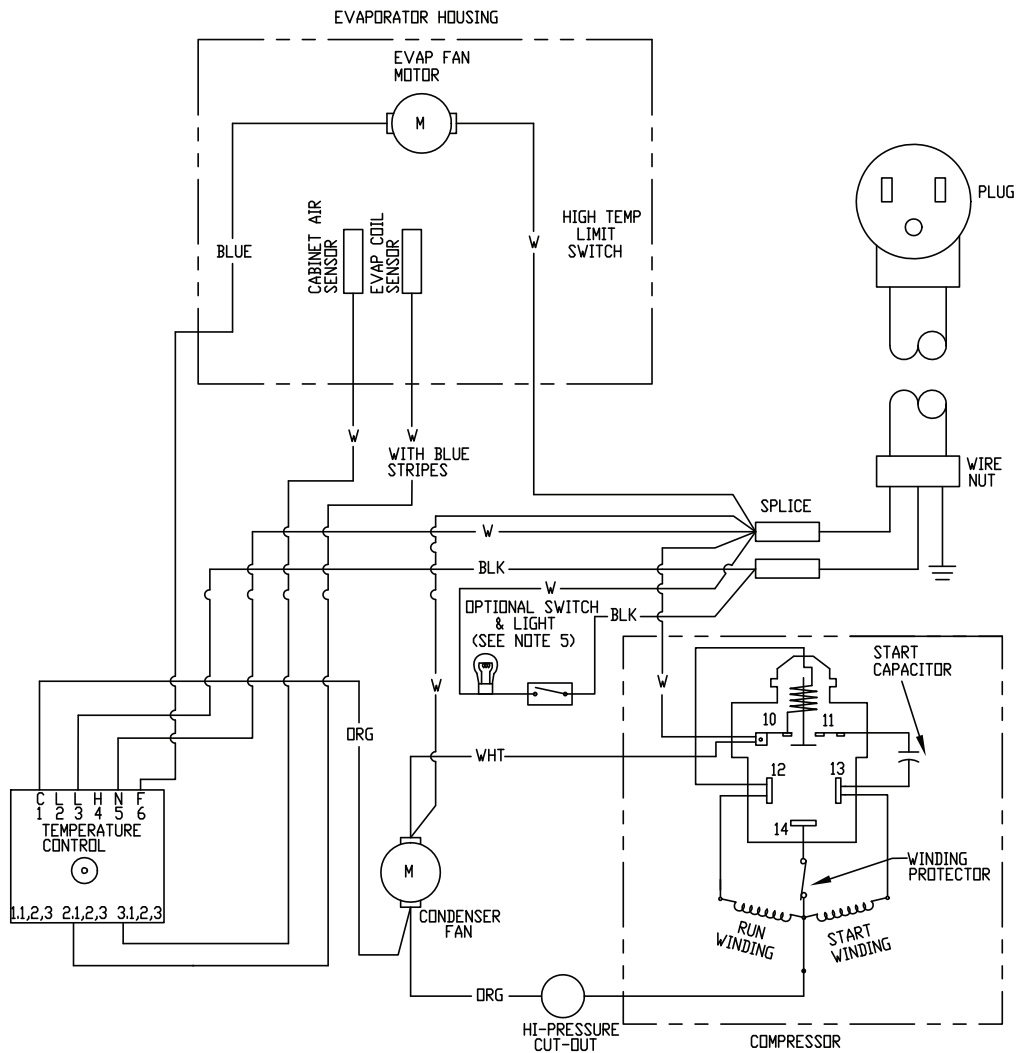

9294473

Wiring Diagram, All Remaining Flat Top Refrigerators

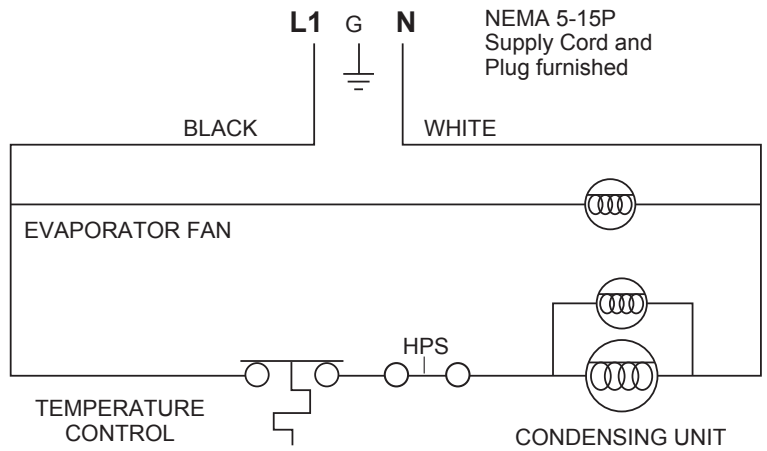

Wiring Diagram, Salad & Mega Top Refrigerators

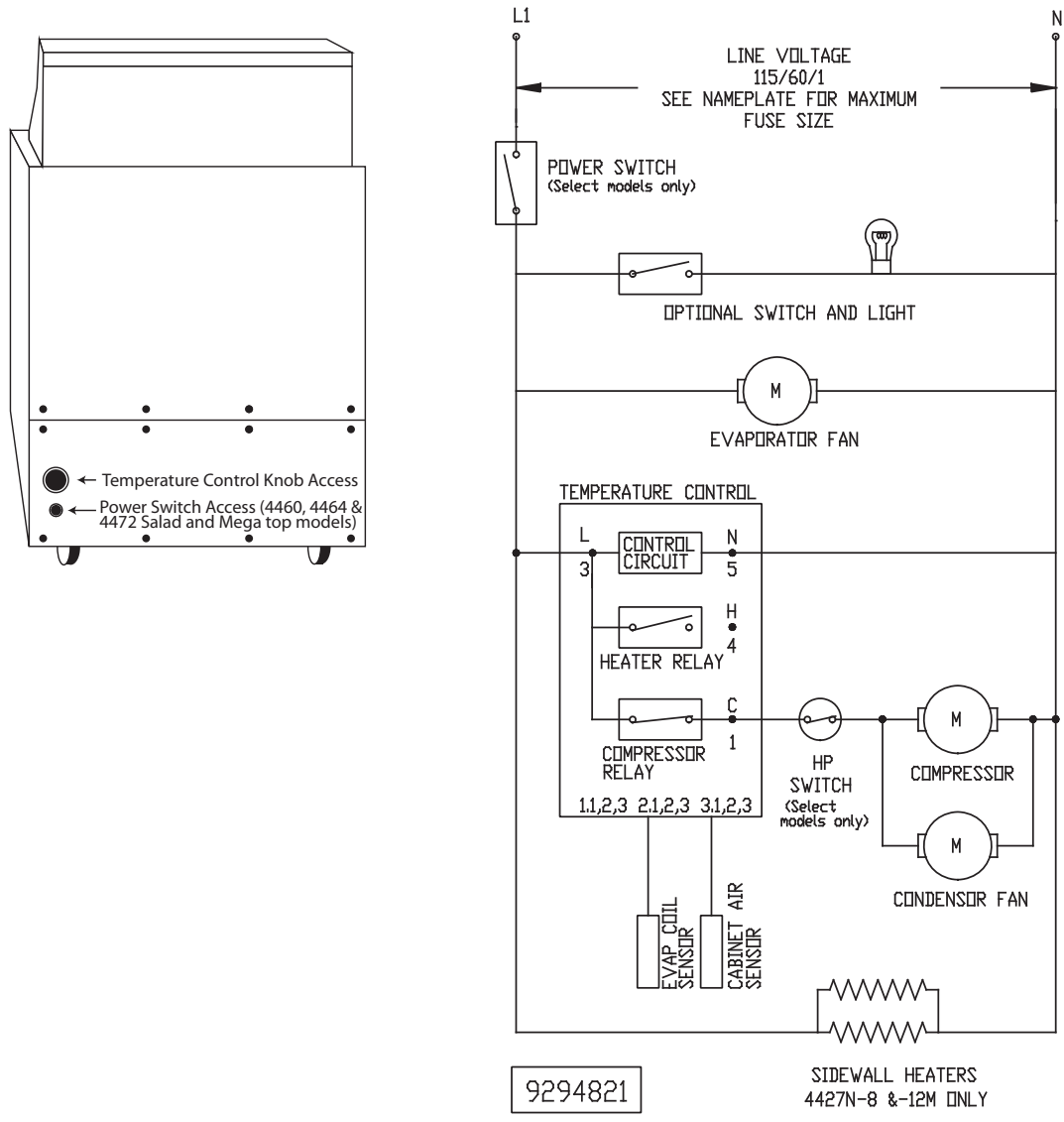

Wiring Diagram, Freezers

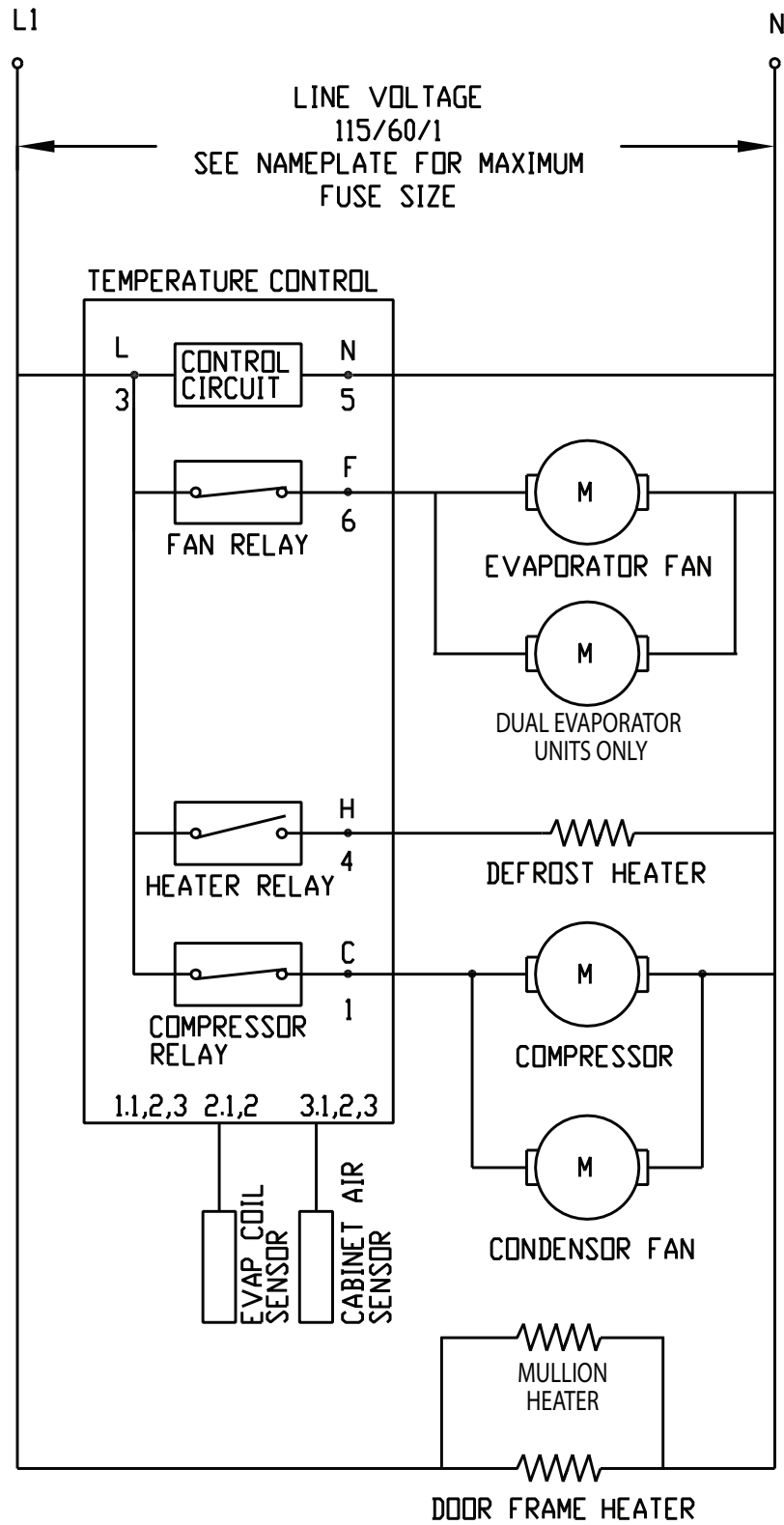

Standard Labor Guidelines To Repair Or Replace Parts On Delfield Equipment

Advice and recommendations given by Delfield Service Technicians do not constitute or guarantee any special coverage.

- A maximum of 1-hour is allowed to **diagnose a defective component**.
- A maximum **travel distance** of 100 miles round trip and 2-hours will be reimbursed. Actual travel to be charged.
- Overtime, installation/start-up, normal control adjustments, general maintenance, glass breakage, freight damage, and/or correcting and end-user installation error will not be reimbursed under warranty unless pre-approved with a **Service Work Authorization** from Delfield. You must submit the number with the service claim.
- Actual repair time will be paid at or below guideline.
- Parts on the critical stock list must be air freighted at the expense of the service agent.

Labor Up To 1-Hour Is Allowed To Replace

- Infinite Switch
- Door Jamb Switch
- Solenoid Coil
- Hi-limit/Thermal Protector Switch
- Fan Delay/Defrost Termination Switch
- Compressor Start Components and Overload Protector
- Defrost Timer
- Thermostat
- Thermometer
- Gear Motor
- Contactor/Relay
- Transformer
- Evaporator/Condenser Fan Motor and Blade
- Circulating Fan Motor and Blade
- Digital Control
- Water Level Sensor/Probe
- Door Hinges, Locks, and Gaskets
- Condensate Element
- Springs/Lowerator

Labor Up To 2 Hours To Replace

- Drawer Tracks/Cartridges
- Pressure Control
- Solenoid Valve
- Defrost Element
- Heating Element
- Locate/Repair Leak

Labor Up To 3 Hours To Replace

- EPR or CPR Valve
- Expansion Valve
- Condenser or Evaporator Coil
- Cap Tube

Labor Up To 4 Hours To Replace

- Compressor
 - This includes recovery of refrigerant and leak check.
 - \$55.00 maximum reimbursement for refrigerant recovery (includes recovery machine, pump, torch, oil, flux, minor fittings, solder, brazing rod, nitrogen, or similar fees).

Refrigerants

- R22 A maximum of \$4.00/lb. or 25¢/oz. will be reimbursed.
- R134A A maximum of \$7.00/lb. or 44¢/oz. will be reimbursed.
- R404A A maximum of \$16.00/lb. or \$1.00/oz. will be reimbursed.



Mt. Pleasant, MI



Covington, TN

Thank you for choosing Delfield!

Help is a phone call away. Help our team of professional, courteous customer service reps by having your model number and serial number available at the time of your call (800) 733-8829.

Model: _____ S/N: _____

Installation Date: _____



For a list of Delfield's authorized parts depots, visit our website at www.delfield.com

Register your Delfield warranty online. Go to www.delfield.com under the service tab to complete.

