



**Copeland Scroll™ Outdoor Refrigeration Unit
X-Line User Manual**

TABLE OF CONTENTS

<u>Section</u>	<u>Page</u>	<u>Section</u>	<u>Page</u>
1. Introduction	4		
2. Nomenclature	4		
3. Electrical/Physical Data	5		
4. Installation/Piping Instructions	5		
5. Quick Setup Guide	6		
6. User Interface	7		
6.1. Button Descriptions and Key Combinations.....	8	6.21.2. EVI SYSTEM CHECKS	
6.2. Changing a Parameter Value.....	8	(XFAL Units Only)	14
6.3. Entering the Advanced Options Menu	8	6.21.3 Constant Liquid Temperature Mode for	
6.4. Moving Parameters Between the Programming		Low Ambient EVI Injection.....	14
Menu and the Advanced Options Menu.....	8	6.22. Medium Temperature DLT Protection	14
6.5. Locking the Keypad	8	6.22.1. Medium Temperature DLT Protection	
6.6. Unlocking the Keypad	8	Error Handling.....	14
6.7. Changing Clock Setting	9	6.23. Over-Current Protection.....	14
6.8. Refrigerant Selection	9	6.24. Incorrect Phase Sequence Protection (3 Phase	
6.9. Fast Access Menu.....	9	Only)	15
6.9.1 List of Fast Access Parameters	9	6.25. Loss of Phase Protection - Current (3 Phase	
6.10. Alarm Menu.....	10	Only)	15
6.11. How to Program a Hot Key From the Controller		6.26. Open Run Circuit (Single Phase Only)	15
(UPLOAD).....	10	6.27. Open Start Circuit	15
6.12. How to Program a Controller Using a Hot Key		6.28. Over/Under Voltage Protection	15
(download)	10	6.29. Phase Imbalance (3 Phase Only)	15
6.13. Manual Stepper Control Mode for Vapor Injection		6.30. Compressor Internal Thermal Protection	15
(Low Temp) or Liquid Injection (Medium Temp).....	10	6.31. Fixed High Pressure Control.....	16
6.14. Controller Startup.....	11	6.32. Alarm Contact	16
6.15. Bump Start Control Operation.....	11	6.33. Anti-Floodback Warning.....	16
6.16. Compressor Stop Program	11	6.34. High Condensing Temperature Warning	16
6.17. Crankcase Heater	12	7. Condensing Unit Operational Control	16
6.18. Suction Pressure Control.....	12	8. Physical and Installation Requirements	17
6.19. Fan Control	12	9. Wiring Diagrams	20
6.19.1. Fan Overrides and Error Handling	12	10. Refrigerant Liquid Temperature Valve	
6.20. Defrost Controls	13	Capacity Multiplier Correction Factors	28
6.20.1. Holiday Defrosts.....	13	11. Alarm Codes	29
6.20.2. Defrost Functionality	13	12. Sensor Values	31
6.20.3. Liquid Line Solenoid Control	13	13. Parameters	32
6.21. Enhanced Vapor Injection (EVI) for Low			
Temperature Units.....	13		
6.21.1. Low Temp EVI Discharge Line			
Temperature Protection Mode.....	13		
6.21.1.1. Low Temp EVI Discharge Line			
Temperature Protection Error			
Handling.....	14		

Safety Instructions

Copeland Scroll™ compressors are manufactured according to the latest U.S. and European Safety Standards. Particular emphasis has been placed on the user's safety. Safety icons are explained below and safety instructions applicable to the products in this bulletin are grouped on Page 3. These instructions should be retained throughout the lifetime of the compressor. **You are strongly advised to follow these safety instructions.**

Safety Icon Explanation



DANGER indicates a hazardous situation which, if not avoided, will result in death or serious injury.



WARNING indicates a hazardous situation which, if not avoided, could result in death or serious injury.



CAUTION, used with the safety alert symbol, indicates a hazardous situation which, if not avoided, could result in minor or moderate injury.







NOTICE is used to address practices not related to personal injury.



CAUTION, without the safety alert symbol, is used to address practices not related to personal injury.

Instructions Pertaining to Risk of Electrical Shock, Fire, or Injury to Persons

 WARNING	<p>ELECTRICAL SHOCK HAZARD</p> <ul style="list-style-type: none"> • Disconnect and lock out power before servicing. • Discharge all capacitors before servicing. • Use compressor with grounded system only. • Molded electrical plug must be used when required. • Refer to original equipment wiring diagrams. • Electrical connections must be made by qualified electrical personnel. • Failure to follow these warnings could result in serious personal injury.
 WARNING	<p>PRESSURIZED SYSTEM HAZARD</p> <ul style="list-style-type: none"> • System contains refrigerant and oil under pressure. • Remove refrigerant from both the high and low compressor side before removing compressor. • Use appropriate back up wrenches on rotalock fittings when servicing. • Never install a system and leave it unattended when it has no charge, a holding charge, or with the service valves closed without electrically locking out the system. • Use only approved refrigerants and refrigeration oils. • Personal safety equipment must be used. • Failure to follow these warnings could result in serious personal injury.
 WARNING	<p>BURN HAZARD</p> <ul style="list-style-type: none"> • Do not touch the compressor until it has cooled down. • Ensure that materials and wiring do not touch high temperature areas of the compressor. • Use caution when brazing system components. • Personal safety equipment must be used. • Failure to follow these warnings could result in serious personal injury or property damage.
 CAUTION	<p>COMPRESSOR HANDLING</p> <ul style="list-style-type: none"> • Use the appropriate lifting devices to move compressors. • Personal safety equipment must be used. • Failure to follow these warnings could result in personal injury or property damage.

Safety Statements

- Refrigerant compressors must be employed only for their intended use.
- Only qualified and authorized HVAC or refrigeration personnel are permitted to install, commission and maintain this equipment.
- Electrical connections must be made by qualified electrical personnel.
- All valid standards and codes for installing, servicing, and maintaining electrical and refrigeration equipment must be observed.

1. Introduction

Copeland Scroll™ Outdoor Refrigeration Units provide the many benefits of scroll compressor technology, coupled with advanced diagnostic controls, to ensure reliable performance and operation in foodservice applications.

Electronics are used extensively in its protection and diagnostic features. These features are controlled by an electronic integrated control module. The Dixell™ XCM25D control module with CoreSense™ technology provides control functions related to temperature and pressure control, defrost, and compressor protection.

Units are available in 1.5 to 6 HP for coolers and 2 to 6 HP for freezers. All units are 208/230 volts and are available in single or three phase. All -081 bill of material units come factory equipped with a heated and insulated receiver, service valves, pressure controls, defrost control, filter drier, moisture indicator, crankcase heater, variable speed condenser fan, CoreSense Protection, CoreSense Diagnostics, and two-way communications standard.

Low temperature XFAL units (-40°F to 0°F saturated suction) also feature an accumulator and oil separator. Discharge line temperature control is provided by enhanced vapor injection (EVI).

Medium temperature XFAM units (0°F to +45°F saturated suction) include all the standard features.

Discharge line temperature control is accomplished by suction line liquid injection.

Extended medium temp XFAP units (-25F to +45F saturated suction) feature an accumulator. Discharge line temperature control is accomplished by suction line liquid injection.

The Dixell XCM25D Electronic Control Module with CoreSense technology (control module) on Copeland™ condensing units provides many benefits to the contractor and end-user. It is designed specifically for demanding refrigeration applications to ensure simple installation and precision operation. While the control module replaces existing adjustable low pressure controls, fan cycle switches and other relays, it also has additional features. These features include bump start, data storage, communication, and short cycling protection.

The control module is preprogrammed with the proper settings, resulting in little to no setup time. The unit comes with instructions showing how to adjust the low pressure cut-in and cut out. See the label on the inside of the enclosure for more information.

Condensing unit operating range: -40°F to +120°F

2. Nomenclature

X	F	A	M	-	0	2	0	Z	-	T	F	C	-	0	8	1
Family = X-Line	F = Multi-refrigerant	A = Air-Cooled	L = Low Temp M = Medium Temp P = Multiple Applications		1.5 to 6.0 = H.P.			Z = Scroll		CFV = 208/230V-1ph-60Hz TFC = 208/230V-3ph-60Hz				0 = UL Listed Product	81 = Standard	
Base Model									Electrical			Bill of Material				

3. Electrical/Physical Data

Model	Compressor	# of Fans	Overall Dimensions (in)			Refrigerant Connections		Receiver Capacity (Lbs @ 90% Volume)								MCA	Max Fuse*	Defrost Relay Rating* (Amps)	Ship Weight (lbs)
			L	W	H	Liquid	Suction	R-134a	R-22	R-404A	R-407A	R-407C	R-507A	R-448A*	R-449A*				
XFAL-020Z-CFV	ZXI06KCE-PFV	1	16.7	40.5	33.1	1/2 S	7/8 S	N/A	N/A	9.1	10	10	9.1	NA	NA	21.55	35	40	246
XFAL-020Z-TFC	ZXI06KCE-TF5	1	16.7	40.5	33.1	1/2 S	7/8 S	N/A	N/A	9.1	10	10	9.1	NA	NA	16.18	25	40	246
XFAL-030Z-TFC	ZXI09KCE-TF5	1	16.7	40.5	33.1	1/2 S	7/8 S	N/A	N/A	9.1	10	10	9.1	NA	NA	17.18	25	40	246
XFAL-035Z-CFV	ZXI11KCE-PFV	1	16.7	40.5	33.1	1/2 S	7/8 S	N/A	N/A	9.1	10	10	9.1	NA	NA	34.05	50	40	272
XFAL-040Z-CFV	ZXI14KCE-PFV	2	16.7	40.5	48.9	1/2 S	7/8 S	N/A	N/A	13.4	14.8	14.7	13.4	NA	NA	40.1	60	40	274
XFAL-040Z-TFC	ZXI14KCE-TF5	2	16.7	40.5	48.9	1/2 S	7/8 S	N/A	N/A	13.4	14.8	14.7	13.4	NA	NA	27.1	45	40	312
XFAL-050Z-TFC	ZXI15KCE-TF5	2	16.7	40.5	48.9	1/2 S	7/8 S	N/A	N/A	13.4	14.8	14.7	13.4	NA	NA	28.85	45	40	323
XFAL-051Z-CFV	ZXI16KCE-PFV	2	16.7	40.5	48.9	1/2 S	7/8 S	N/A	N/A	13.4	14.8	14.7	13.4	NA	NA	44.73	70	40	343
XFAL-060Z-TFC	ZXI18KCE-TF5	2	16.7	40.5	48.9	1/2 S	7/8 S	N/A	N/A	13.4	14.8	14.7	13.4	NA	NA	33.98	50	40	341
XFAM-015Z-CFV	ZS09KAE-PFV	1	16.7	40.5	33.1	1/2 S	7/8 S	10.7	10.5	9.1	10	10	9.1	9.7	9.7	13.55	20	40	218
XFAM-015Z-TFC	ZS09KAE-TF5	1	16.7	40.5	33.1	1/2 S	7/8 S	10.7	10.5	9.1	10	10	9.1	9.7	9.7	11.05	15	40	219
XFAM-017Z-CFV	ZS11KAE-PFV	1	16.7	40.5	33.1	1/2 S	7/8 S	10.7	10.5	9.1	10	10	9.1	9.7	9.7	16.8	25	40	219
XFAM-017Z-TFC	ZS11KAE-TF5	1	16.7	40.5	33.1	1/2 S	7/8 S	10.7	10.5	9.1	10	10	9.1	9.7	9.7	14.05	20	40	219
XFAM-022Z-CFV	ZS15KAE-PFV	1	16.7	40.5	33.1	1/2 S	7/8 S	10.7	10.5	9.1	10	10	9.1	9.7	9.7	20.68	35	40	220
XFAM-022Z-TFC	ZS15KAE-TF5	1	16.7	40.5	33.1	1/2 S	7/8 S	10.7	10.5	9.1	10	10	9.1	9.7	9.7	14.3	20	40	219
XFAM-030Z-CFV	ZS21KAE-PFV	1	16.7	40.5	33.1	1/2 S	7/8 S	10.7	10.5	9.1	10	10	9.1	9.7	9.7	30.05	50	40	236
XFAM-030Z-TFC	ZS21KAE-TF5	1	16.7	40.5	33.1	1/2 S	7/8 S	10.7	10.5	9.1	10	10	9.1	9.7	9.7	20.05	30	40	236
XFAM-045Z-CFV	ZS33KAE-PFV	2	16.7	40.5	48.9	1/2 S	7/8 S	15.7	15.5	13.4	14.8	14.7	13.4	14.2	14.3	37.35	60	40	285
XFAM-045Z-TFC	ZS33KAE-TF5	2	16.7	40.5	48.9	1/2 S	7/8 S	15.7	15.5	13.4	14.8	14.7	13.4	14.2	14.3	29.98	50	40	280
XFAM-050Z-CFV	ZS38K4E-PFV	2	16.7	40.5	48.9	1/2 S	7/8 S	15.7	15.5	13.4	14.8	14.7	13.4	14.2	14.3	41.85	70	40	292
XFAM-050Z-TFC	ZS38K4E-TF5	2	16.7	40.5	48.9	1/2 S	7/8 S	15.7	15.5	13.4	14.8	14.7	13.4	14.2	14.3	28.85	45	40	292
XFAM-060Z-TFC	ZS45K4E-TF5	2	16.7	40.5	48.9	1/2 S	7/8 S	15.7	15.5	13.4	14.8	14.7	13.4	14.2	14.3	31.98	50	40	299
XFAP-015Z-CFV	ZS09KAE-PFV	1	16.7	40.5	33.1	1/2 S	7/8 S	10.7	10.5	9.1	10	10	9.1	9.7	9.7	13.55	20	40	233
XFAP-015Z-TFC	ZS09KAE-TF5	1	16.7	40.5	33.1	1/2 S	7/8 S	10.7	10.5	9.1	10	10	9.1	9.7	9.7	11.05	15	40	234
XFAP-017Z-CFV	ZS11KAE-PFV	1	16.7	40.5	33.1	1/2 S	7/8 S	10.7	10.5	9.1	10	10	9.1	9.7	9.7	16.8	25	40	234
XFAP-017Z-TFC	ZS11KAE-TF5	1	16.7	40.5	33.1	1/2 S	7/8 S	10.7	10.5	9.1	10	10	9.1	9.7	9.7	14.05	20	40	234
XFAP-022Z-CFV	ZS15KAE-PFV	1	16.7	40.5	33.1	1/2 S	7/8 S	10.7	10.5	9.1	10	10	9.1	9.7	9.7	20.68	35	40	235
XFAP-022Z-TFC	ZS15KAE-TF5	1	16.7	40.5	33.1	1/2 S	7/8 S	10.7	10.5	9.1	10	10	9.1	9.7	9.7	14.3	20	40	234
XFAP-030Z-CFV	ZS21KAE-PFV	1	16.7	40.5	33.1	1/2 S	7/8 S	10.7	10.5	9.1	10	10	9.1	9.7	9.7	30.05	50	40	251
XFAP-030Z-TFC	ZS21KAE-TF5	1	16.7	40.5	33.1	1/2 S	7/8 S	10.7	10.5	9.1	10	10	9.1	9.7	9.7	20.05	30	40	251
XFAP-045Z-CFV	ZS33KAE-PFV	2	16.7	40.5	48.9	1/2 S	7/8 S	15.7	15.5	13.4	14.8	14.7	13.4	14.2	14.3	37.35	60	40	300
XFAP-045Z-TFC	ZS33KAE-TF5	2	16.7	40.5	48.9	1/2 S	7/8 S	15.7	15.5	13.4	14.8	14.7	13.4	14.2	14.3	29.98	50	40	295
XFAP-050Z-CFV	ZS38K4E-PFV	2	16.7	40.5	48.9	1/2 S	7/8 S	15.7	15.5	13.4	14.8	14.7	13.4	14.2	14.3	41.85	70	40	307
XFAP-050Z-TFC	ZS38K4E-TF5	2	16.7	40.5	48.9	1/2 S	7/8 S	15.7	15.5	13.4	14.8	14.7	13.4	14.2	14.3	28.85	45	40	307
XFAP-060Z-TFC	ZS45K4E-TF5	2	16.7	40.5	48.9	1/2 S	7/8 S	15.7	15.5	13.4	14.8	14.7	13.4	14.2	14.3	31.98	50	40	314

Generator Requirements: In situations or locations where an electrical power generator is used for backup, the Copeland Scroll Outdoor Refrigeration Unit requires a supply voltage of **186-253 VAC**.

4. Installation/Piping Instructions

A clearance of 8 inches from the wall (or the next unit) is required from the unit's left and rear panel; a clearance of 20 inches is required from the unit's right, top and front panels. (See diagrams in section covering Physical and Installation Requirements) Ensure that the hot discharge air from one unit does not circulate to another unit.

The unit is designed to mount on the ground, on a roof, or on a wall. For ground mounting, the units should be placed on a level solid concrete slab with rubber strips

between the feet and concrete, or other raised support structure. For wall mounting, use a wall bracket system designed for mounting condensing units or universal metal framing strut and follow the manufacturer's instructions. All mounting options must follow local zoning and building codes.

Pipes should be sized for optimum performance and good oil return, and for the full capacity range through which this particular unit will need to operate. Follow the ASHRAE guidelines for proper piping practice.

5. Quick Setup Guide

1 Set the clock

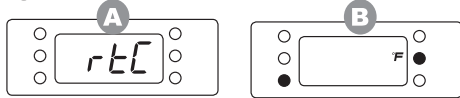

The unit will flash **rtc** the first time power is applied or if the clock has lost its setting.

Press and hold ∇ + SET until **F** flashes.

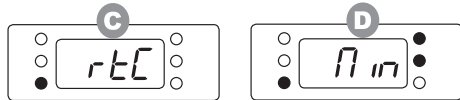

Press SET to select the **rtc** menu.

Use SET and Δ ∇ buttons to select and adjust clock parameters.

Clock Parameters

Par.	Description	Value Range
min	Minute	0-59
hr	Hour	0-23
day	Day	1-31
mon	Month	1-12
year	Year	0-99

2 Set pressure controls

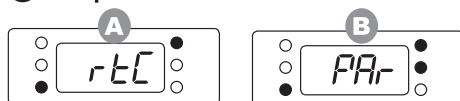

Press SET and Δ to exit the **rtc** menu. If SET and Δ are held, the control will exit program mode. Use ∇ and SET to return to program mode.

Use the Δ or ∇ buttons to find the **PAR** menu, then press SET to select.

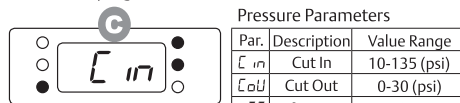

Use SET and Δ ∇ buttons to select and adjust pressure parameters.

Pressure Parameters

Par.	Description	Value Range
cin	Cut In	10-135 (psi)
cout	Cut Out	0-30 (psi)
ref	Refrigerant	22, 134, 404, (4)07A, (4)07C, 507 (may vary by model)

3 Set defrost parameters and schedule

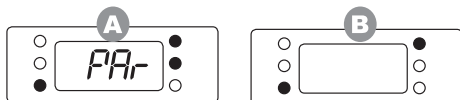

From the **PAR** menu, use SET and Δ ∇ buttons to select and adjust defrost parameters.

Press and hold SET and Δ to exit program mode.

Defrost Parameters

Par.	Description	Value Range
idf	Interval between defrost	0-120 (hours)
ndf	Max duration	0-255 (minutes)
edf	Defrost mode	nU (off), in (interval), rtc (clock)
ld1	1st start time	nU (not used), 0-23:50
ld2	2nd start time	
ld3	3rd start time	
ld4	4th start time	
ld5	5th start time	
ld6	6th start time	

2015ECT-41 (10/15) - 052-7289-02

IMPORTANT BEFORE PROGRAMMING - DETERMINE DESIRED DEFROST MODE

- Press and Hold SET + DOWN for 3 seconds
- Using arrows scroll to RTC and select by pressing SET
- Press UP or DOWN and select EdF
- Press SET and select interval mode (in), real time clock mode (rtc), or not used (nU)
- Press SET to confirm section then proceed to step 6 if (in) selected, or step 8 if (rtc) selected

Interval Mode (in) - Interval between defrost cycles
RTC Mode (rtc) - Real time clock based defrost schedule
Not Used Mode (nU) - Defrost not used

IF USING INTERVAL DEFROST MODE (in)

- Scroll through options and select (idf) by pressing SET. Scroll to desired defrost interval (hours) and confirm by pressing SET.
- Scroll through options and select (Ndf) by pressing SET. Scroll to desired defrost duration (minutes) and confirm by pressing SET.

IF USING TIME OF DAY DEFROST MODE (rtc)

- Scroll to Ld1 and confirm by pressing SET. Set desired defrost time (0.1 = 12:10AM, 13.5 = 1:50PM) and confirm by pressing SET
- Scroll to Ld2-Ld6 and repeat step 8 for each desired time of day. Set all unneeded options to (nU)

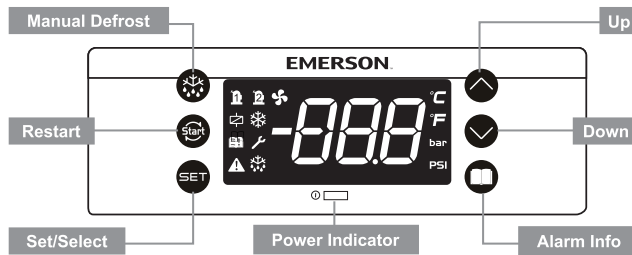

Navigation

Enter program mode* ∇ + SET 3 seconds (F flash)

Cycle through options/adjust values Δ ∇

Select function/store function SET

Exit program mode Δ + SET

*Program mode will terminate after 60 seconds of inactivity.

View Values and Set Points

From main screen, press and release	Δ
Cycle through parameters	Δ ∇
Select value	SET
Go to next parameter	SET
Exit menu	Δ + SET

*Program mode will terminate after 60 seconds of inactivity.

Values and Set Points

Par	Description	Par	Description
P1P	Suction Pressure	oPP	EXV %
P2t	Cond. Temp.	L1.5	NA
P2P	NA	Roo	Fan Speed %
P3t	DLT	d5a	NA
P4t	Vapor Inlet	Lt	NA
P5t	Vapor Outlet	Ht	NA
P6t	Ambient Temp	Hr	RTC Menu
P7t	Liquid Line Temp	5td	Dynamic Fan Set Point
5H	NA		

Code	Description	Code	Description
01	A11	27	Over voltage
02	A12	28	Compressor Build-in protector trip
03	A13	29	Power frequency (manual)
04	A14	40	High pressure switch
05	A15	41	Low pressure switch
06	A16	42	High pressure
07	A17	43	Low pressure
08	Battery	44	Discharge line temperature
09	Current sensor 1	46	High condenser temperature
10	Current sensor 2	47	EXV full open in EVI
11	Voltage sensor 1	48	Refrigerant shortage error in EVI
12	Voltage sensor 2	49	Pump down alarm
13	Voltage sensor 3	50	High side flood back
20	Lost phase	80	RTC warning, date not correct
21	Phase sequence	81	RTF warning, communication with clock
22	Phase Imbalance	82	Probe configuration
23	Over current	83	DI configuration
24	Open run circuit	84	Compressor configuration
25	Open start circuit	85	Injection probe configuration
26	Under voltage	86	EEPROM R/W (manual)

E-Error L= Lockout

6. User Interface









The controller display is shown below along with the function of each light. The controller displays the current suction pressure to three digits in pounds per square inch gage (psig). The controller uses a 7-segment display for digits and the following alpha characters:

The 7-segment alphabet and Roman equivalent:









A	b	C	d	E	F	H	i	L	M	n	o	P	q	r	S	T	U	Y	0	1	2	3	4	5	6	7	8	9
A	b	C	d	E	F	H	i	L	M	n	o	P	q	r	S	T	U	Y	0	1	2	3	4	5	6	7	8	9

The letters G, J, K, Q, V, W, X and Z are not used on the 7-segment display.









LED	MODE	FUNCTION
	ON	Compressor enabled
	Flashing	Anti-short cycle delay enabled
	ON	Condensing fans enabled
	ON	Display temperature value in degrees F
	Flashing	Programming mode
	ON	Display pressure value in PSI
	ON	Browsing service menu
	Flashing	Fast access menu (Viewing set points and measured values)
	ON	Browsing the alarm menu
	Flashing	New alarm occurred
	ON	An alarm is occurring
	ON	In defrost or evap fan drip time when ON
	ON	Evaporator fans enabled

6.1. Button Descriptions and Key Combinations

	(SET) Select a parameter or confirm an operation when in programming mode.
	(RESTART) Hold for 5 seconds to reset any lockouts if the current state of the controller allows for reset. Allows a manual restart and a “dead band reset”.
	(UP) View current measured values (Fast Access Menu); in programming mode or any menu to browse the parameter codes or increase the displayed value.
	(DOWN) in programming mode or any menu to browse the parameter codes or decrease the displayed value.
	(SERVICE) To enter the service and alarm menu.
	Hold for 3 seconds to start a manual defrost
	Press and hold for about 3 sec to lock (Pon) or unlock (PoF) the keyboard.
	Press together to exit from programming mode or from menu; on submenus to return to previous level.
	Press together for 3 sec to access to first level of programming mode.

6.2. Changing a Parameter Value

To change a parameter value:





1. Hold down **SET +**  keys for 3 seconds or until the 'F' LED starts blinking to enter the module's programming menu.
2. Use  or  to select the rtC or PAr menu
3. Press **SET** to enter the menu.
4. Use  or  to select the required parameter.
5. Press the **SET** key to display its value.
6. Use  or  to change its value.
7. Press **SET** to store the new value.

TO EXIT: Press **SET +**  or wait 60 seconds without pressing a key.

NOTE: The set value is stored even when the procedure is exited by waiting for the time-out to expire.

NOTE: If a menu does not have any parameters available, noP will be displayed

6.3. Entering the Advanced Options Menu

1. Hold down **SET +**  keys for 3 seconds or until the F LED starts blinking to enter the module's programming menu.
2. Use  or  to select the PAr menu
3. Press **SET** to enter the PAr menu
4. Use  or  to select the PAS parameter
5. Press **SET** to select PAS
6. The blinking PAS label will be showed for a few seconds
7. Will be showed 0 - - with blinking 0: insert the password [321] using the keys UP and DOWN and confirming with SET key.



6.4. Moving Parameters Between the Programming Menu and the Advanced Options Menu

While in the advanced options menu, certain parameters will have a (.period) in between the 2nd and 3rd character, for example Ci.n. These parameters are in the Programming Menu as well as the Advanced Options Menu.



To add or remove a parameter from the programming menu, press the **SET +**  keys together while the parameter name is on the display in the advanced options menu. The (.period) between the 2nd and 3rd parameter will either be added or removed.

TO EXIT: Press **SET +**  or wait 60 seconds without pressing the keys.

6.5. Locking the Keypad

1. Press the  +  keys for 3 seconds.
2. The POF message will be displayed and the keyboard will be locked. The Fast Access Menu will remain accessible while the keyboard is locked.
3. If a key is pressed more than 3 seconds the POF message will be displayed.

6.6. Unlocking the Keypad

Press the  +  keys for 3 seconds until the Pon message is displayed.

6.7. Changing Clock Setting

1 Set the clock

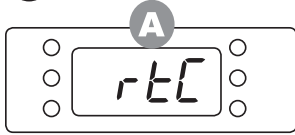

The unit will flash *rEtC* the first time power is applied or if the clock has lost its setting.

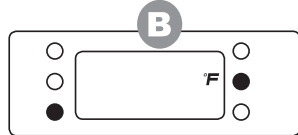

Press and hold ∇ + SET until *F* flashes.

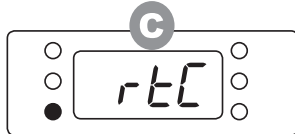

Press SET to select the *rEtC* menu.



Use SET and \triangle ∇ buttons to select and adjust clock parameters.

Clock Parameters

Par.	Description	Value Range
<i>Pi n</i>	Minute	0-59
<i>Hr</i>	Hour	0-23
<i>PdY</i>	Day	1-31
<i>Pbn</i>	Month	1-12
<i>yEr</i>	Year	0-99

6.8. Refrigerant Selection

Using parameter REF set the refrigerant as follows (refer to nameplate for approved refrigerants):

Refrigerant	rEF
R-404A	404
R-507	507
R-134A	134
R-22	r22
R-407C	07C
R-407A	07A
R-407F	07F
R-448A	48A
R-449A	49A

6.9. Fast Access Menu

This menu allows viewing measured values from various probes and view some outputs resulting from these measurements. The values nP or noP stand for probe not present or value not evaluated. Err means the value is out of range, probe is damaged, not connected, or incorrectly configured.

Press \triangle to enter the Fast Access Menu.

Use \triangle or ∇ arrows to select an entry, then press SET to see the value or to go on with other value.







TO EXIT: Press SET + \triangle or wait 60 seconds without pressing the keys.

6.9.1. List of Fast Access Parameters:

<i>PiP</i>	P1P	Suction pressure
<i>P2t</i>	P2t	Condenser temperature
<i>P2P</i>	P2P	Not Used
<i>P3t</i>	P3t	Discharge line temperature
<i>P4t</i>	P4t	EVI heat exchanger vapor inlet temperature (XFAL only)
<i>P5t</i>	P5t	EVI heat exchanger vapor outlet temperature (XFAL only)
<i>P6t</i>	P6t	Ambient temperature
<i>P7t</i>	P7t	Liquid line temperature (XFAL only)
<i>5H</i>	5H	Not used
<i>oPP</i>	oPP	Percentage of liquid injection (XFAP/ XFAM) or vapor injection (XFAL) valve opening.
<i>LLS</i>	LLS	Not used
<i>Std</i>	Std	Current condenser temperature target for fan speed control
<i>A00</i>	A00	Fan speed percent
<i>d5o</i>	d5o	Not used
<i>Lt</i>	Lt	Not used
<i>Ht</i>	Ht	Not used
<i>tU1</i>	tU1	Line voltage (1-phase)
<i>tU2</i>	tU2	Line voltage (3-phase)
<i>tU3</i>	tU3	Line voltage (3-phase)
<i>tA1</i>	tA1	Current (1-phase)
<i>tA2</i>	tA2	Current (3-phase)
<i>tA3</i>	tA3	Current (3-phase)
<i>HM</i>	HM	Menu

6.10. Alarm Menu

The controller time-stamps and stores the last 50 alarms. See Section 11 for alarm codes.

Action	Button	Notes
Enter alarm menu		Push and release alarm key (Displays SEC when alarm menu is active)
Enter alarm list	SET	Press SET to confirm
Scroll through active and recorded alarm list	 Or 	Scroll the list of alarms and see the list of active alarms with the number of the alarm (Letter+Number, A01-A50). Push Down key and see the alarm Name or Code. Push Down key and see the next active alarm
Select the alarm to see the date and time	SET	Enter the sub menu with alarm time details
Scroll through alarm information data	 Or 	Successive presses of the down arrow button will display the clock data label (hour, minute, day, month, year) followed by the value of the preceding label. The up arrow will reverse this order and show the value followed by the label. The displayed values record the start time of an alarm.
Exit menu	SET + 	Press SET and UP together or wait about 10 seconds.

6.11. How to Program a HOT-KEY From the Controller (UPLOAD TO OVERWRITE HOT-KEY)

Caution: Overwrites hot key. When the controller is ON, insert the HOT-KEY into the 5-PIN receptacle (labeled H-K) and push the  button; the **UPL** message appears followed a by a flashing **End** label.

Push SET button and the **End** will stop flashing.

Turn OFF the controller, remove the HOT-KEY and then turn the controller ON again.

NOTE: the **Err** message appears in case of a failed programming operation. In this case push the  again if you want to restart the upload again or remove the HOT-KEY to abort the operation.

6.12. How to Program a Controller Using a HOT-KEY (Download)

A hot key is included with each unit for factory reset and replacement control programming. Remove power from the unit.

Insert a pre-programmed HOT-KEY into the 5-PIN receptacle (labeled H-K) and reapply power to the unit.

The parameter list of the HOT-KEY will be automatically downloaded into the controller memory. The **doL** message will blink followed by a flashing **End** label.

After 10 seconds the controller will restart and begin

working with the new parameters.

Remove the HOT-KEY

NOTE: The message **Err** is displayed for failed programming. In this case turn the unit off and then on if you want to restart the download again or remove the HOT-KEY to abort the operation.

6.13. Manual Stepper Control Mode for Vapor Injection (Low Temp) or Liquid Injection (Medium Temp)

For troubleshooting purposes, the stepper setting can temporarily be manually adjusted.

From the standard display screen, pressing SET and SERVICE/ALARM key for 3 seconds will enter a manual stepper control mode.

In the manual stepper control mode, the display shows the current step count of the valve.

In manual stepper control mode, all algorithms controlling the stepper valve are suspended, but the rest of the functions operate normally

The up and down arrows on the keypad open and close the valve, with the display showing the updated step count

If the controller is left untouched for 60 seconds or the set and up button are pressed together to exit, the controller will resume normal operation.

Condensing Unit Operational Control

The X-Line control module operates the condensing unit and ensures the system remains in correct operating conditions. It controls the follow items:

- Compressor
- Condenser Fan Motor(s)
- Crank Case Heater
- Receiver Heater
- Defrost Heater (If connected)

The X-line Unit will protect the system from the following fault conditions (See Sections 6.23 through 6.31 for further details):

- Discharge Line Temperature Protection
- Over-Current Protection
- Incorrect Phase Sequence Protection (3 Phase Only)
- Loss of Phase Protection - Current (3 Phase Only)
- Open Run Circuit (Single Phase Only)
- Open Start Circuit (Single Phase Only)
- Over/ Under Voltage Protection
- Phase Imbalance (3 Phase Only)
- Compressor Internal Thermal Protection
- Fixed High Pressure Control

In addition, the X-Line unit has protection features that will prevent it from reaching a fault condition. For example, when the low temperature unit experiences an extremely hot day, the control module decides to switch from vapor-injection-optimization to discharge gas temperature control to allow the compressor to run safely and pass the extreme weather hours.

6.14. Controller Startup

At initial power up, the controller display will display the following information:

All LEDs will light up for approximately 2 seconds.

For 3 seconds, the controller will display the firmware version (EX: 1.0, 1.1, etc.)

For three seconds the controller will display the program number (EX: 100, 101, 200, etc.)

The controller will then wait 6 seconds before turning on the compressor or any other device.

Once the controller calls for the compressor to run and there are no active alarms, the controller will then turn on the compressor utilizing bump start (if needed per Section 6.15) and control the fans and compressor.

6.15. Bump Start Control Operation

If the ambient temperature sensor reads less than 95°F when the controller is first turned on or after the compressor has been off for 4 hours and now is being turned on, the compressor will initiate a bump start. If the ambient temperature sensor is not functioning, the mid-coil temperature sensor will determine if the unit will initiate a bump start or not.

The compressor and fans will run for 2 seconds then turn off for 15 seconds three times. Once this sequence is completed, the unit resumes normal operation.

The crank case heater will remain off during the bump start sequence.

If liquid injection, vapor injection, or a system EXV is present, the stepper valve will remain closed until the bump start has finished.

In the event of a power loss, the controller can be programmed to enter a defrost at power up if **dPo** is set to **YES**. It is turned off by default, but is adjustable from the advanced options menu.

6.16. Compressor Stop Program

When the compressor needs to turn off, either based on an error or loss of demand, the following items will occur:

- Liquid or Vapor Injection Only: If a non-error shutdown occurs, compressor runs for 5 seconds before turning off to allow the liquid or vapor injection valves to fully close.
- Compressor turns off
- Condenser fans turn off

Crankcase heater turned on (See Section 6.17)

NOTE: During the pump down process with the 5 second delay the compressor may run down into a vacuum. There are no reliability issues in this application.

6.17. Crankcase Heater

The crankcase heater is energized when the ambient temperature is below 50°F and the compressor is off. If an ambient sensor fails, the crankcase heater is energized when the compressor is off.

6.18. Suction Pressure Control

The compressor is operated based on the suction pressure cut-in (**Cin**) and cut-out (**CoU**). If the suction pressure rises above the cut-in, the compressor is turned on using the startup procedure (See Section 6.14). If the suction pressure then falls below the cut-out, it turns the compressor off using the shutdown procedure (See section 6.16).

The compressor remains off for a minimum 120 seconds (**2oF**) after shutdown, which is adjustable in the advanced options menu (See section 6.3).

If the suction pressure transducer fails, the compressor will run in limp along mode. The compressor will stay off for 3 minutes (**CoF**) then run for 3 minutes (**Con**). These values are adjustable from the advanced options menu (See section 6.3).

The cut-in and cut-out settings are adjustable between 0 PSIG and 135 PSIG.

IMPORTANT: At initial power up, depending on the suction pressure transducer, the suction pressure could be higher than the rating of the transducer. For 15 minutes after power up, any over pressure errors generated by the suction pressure transducer should be ignored, and the display will flash 135. If the transducer is still in an error state after the time has expired, the control will alarm that the suction pressure transducer signal is lost, and go into limp along mode.

6.19. Fan Control

The X-line uses variable speed PSC condenser fan motors to maintain the head pressure values that allow the system to operate within the compressor operating envelope and maintain the minimum pressure differential across the expansion device to allow it to operate properly.

The controller uses a Proportional-Integral (PI) control algorithm to determine the fan speed. The fans will not run any slower than 40% before turning off. When a fan first turns on it will run for 3 seconds at full speed before it begins modulating. Fans will run for at least

10 seconds before turning off and stay off for at least 10 seconds before being turned back on.

Since the X-Line controller knows the current suction pressure, the controller can determine the minimum condensing point for the condition the unit is actually running, and will adjust the fan control set point to maintain that temperature or higher.

The XFAP/XFAM and XFAL models have different compressors and different refrigerant options. Therefore, during commissioning, it is important to identify the selected refrigerant so the controller will operate the fans properly.

Low ambient operation

The condensing unit can operate in outdoor ambient temperatures as low as -40°F. The unit will automatically adjust condenser fan speed to maintain head pressure. At extremely low ambient temperature the condenser fan might not run, but the condenser coil is still discharging heat. Parameter LAS sets the ambient temperature required to initiate low ambient on time. The default value is -20°F. Parameter LMO sets the low ambient minimum on time. The default value is 6 seconds. Below -20°F ambient, when the condensing unit runs it will run for a minimum of 6 seconds.

IMPORTANT NOTE: To fully utilize low condensing options below 70°F condensing, an electronic expansion valve (EXV) is normally required to handle the larger variation in mass flows. As a result, the unit is shipped with a default minimum condensing override value of 70°F (80°F for XFAL). The fans will still follow the map of the selected refrigerant, but the map will not be allowed to run below the override value. If you have a system with an EXV installed, you can adjust the value by changing parameter MCS in the advanced options menu.

6.19.1. Fan Overrides and Error Handling

If the discharge line temperature is above 205°F the fans will run at full speed.

If the condenser mid-coil temperature sensor fails, the fan speed is determined by outdoor ambient. If both the outdoor ambient sensor and the condenser mid-coil temperature sensor fail, all fans will run at full speed.

6.20. Defrost Controls.

3 Set defrost parameters and schedule

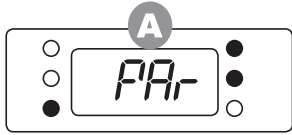

From the *PRF* menu, use **SET** and Δ ∇ buttons to select and adjust defrost parameters.

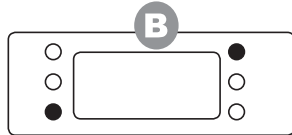

Press and hold **SET** and Δ to exit program mode.

Defrost Parameters

Par.	Description	Value Range
<i>rdF</i>	Interval between defrost	0-120 (hours)
<i>ndF</i>	Max duration	0-255 (minutes)
<i>EdF</i>	Defrost mode	<i>nU</i> (off), <i>n</i> (interval), <i>rtc</i> (clock)
<i>ld1</i>	1st start time	<i>nU</i> (not used), 0-23:50
<i>ld2</i>	2nd start time	
<i>ld3</i>	3rd start time	
<i>ld4</i>	4th start time	
<i>ld5</i>	5th start time	
<i>ld6</i>	6th start time	

2015ECT-41 (10/15) - 052-7289-02

6.20.1. Holiday Defrosts

If you are using real time clock mode (*rtc*), holiday defrosts can be set in the advanced options menu. To set a holiday, change *Hd1* from *nU* to whatever day of the week you would like to have a different defrost schedule. (An example would be if a store is closed on Sundays and needs less defrosts). You can set a second holiday by changing *Hd2*. The defrosts for the set holidays are controlled by parameters *5d1* through *5d6*.

6.20.2. Defrost Functionality

During a defrost the controller will display *dEF*.

To manually initiate a defrost, press and hold the defrost button for 3 seconds.



The controller will terminate defrost after 45 minutes *MDF* (*Pr1* parameter) or after the defrost termination input (Terminal 'X') is closed.

6.20.3. Liquid Line Solenoid Control

By default, the unit assumes that a liquid line solenoid is used to pump down the system during a defrost. When the unit enters a defrost, the evaporator power (Connection 3 on the terminal strip) will turned off, turning off the liquid line solenoid as well. The unit will then run until the suction pressure drops below the cut out value, then turn off the compressor. When the defrost is complete, the unit will apply power to the evaporator, opening the solenoid and the compressor will start running once the suction pressure is above the cut in.

If a pump down solenoid is not present or the unit should not pump down when entering a defrost, parameter *tLS* should be set to *no*. *TLS* is set to *YES* by default.

6.21. Enhanced Vapor Injection (EVI) For Low Temperature Units

The injection valve is a key part of the EVI system. It regulates vapor injection flow to optimize the performance of system and cool the scroll set. When the compressor first calls for power, the injection valve opens a preset amount before the compressor turns on. After startup, the EVI injection valve is controlled using a proportional-integral (PI) algorithm to control the differential between the vapor inlet temperature and the vapor outlet temperature. The differential is 9°F for R404A, R507, R134a, and R22. It is 18°F for other approved refrigerants. The PI algorithm for the EVI injection valve control is auto-adaptive, so it does not need to be adjusted.

6.21.1. Low Temp EVI Discharge Line Temperature Protection Mode

If during normal operation the DLT temperature reaches 225°F the control changes to act as a liquid injection valve to control the DLT temperature. Once the DLT temperature falls below 200°F, normal vapor injection control resumes.

If the discharge temperature goes above 250°F, the compressor trips off and the control displays an *E44* error. The compressor cannot turn back on until the temperature drops below 170°F and has been off for 3 minutes.

If the compressor trips more than 4 times per hour (dLn), the controller will lock out the compressor, requiring a manual reset or the controller power to be reset. The controller will display **L44** showing the compressor has tripped on high DLT and locked out. If parameter dLn, which is available in the advanced options menu, is set to 0, the unit will always automatically reset.

6.21.1.1. Low Temp EVI Discharge Line Temperature Protection Error Handling

In case of DLT failure, the injection valve operates based on the mid coil and ambient sensor.

If the DLT sensor fails and a mid-coil temperature sensor is available, the injection valve will be opened based on the mid coil temperature. If the mid coil sensor fails in addition to the DLT sensor, the injection valve is controlled by the ambient temperature.

6.21.2. EVI System Checks (XFAL units only)

An E47 warning code means that the injection valve has been fully open longer than 3 minutes. An E48 warning code means that the temperature difference across the EVI heat exchanger is higher than expected for 3 minutes. These are only warnings, but are likely due to loss of refrigerant charge or undercharge

6.21.3. Constant Liquid Temperature Mode For Low Ambient EVI Injection

Subcooling is generally good, but liquid refrigerant that is too cold can create sizing problems for TXVs. If the ambient is below 30°F, discharge temperature is generally well under control and so the controller disables vapor injection to operate in constant liquid temperature mode. The low ambient temperature will generate enough subcooling for the system without the need for injection. Emerson recommends a balanced port TXV (or EXV) for low ambient operation.

6.21.4. Low Temperature Units With EVI TXV Selection

For use with low temperature units with EVI, Emerson recommends a balanced port TXV because it offers a wider operating range for floating liquid temperatures. In addition, the unit liquid line should be insulated since the liquid line temperature will be lower than the ambient temperature.

See the table on page 28 for specifics regarding balanced port sizing recommendations. Applied with the low temp units it is recommended that a balanced port expansion valve be used along with a complete review of the distributor and nozzle (orifice) that is supplied with the evaporator coil being matched with the applicable condensing unit. Typically nozzles are selected for standard TXV sizing using 100°F liquid, with the low temperature X-Line units those typical selections could be grossly oversized. See the table on page 28 for the liquid correction safety factors when selecting those components.

6.22. Medium Temperature DLT Protection

Medium Temperature units have liquid injection through the suction line to prevent compressor overheat during extreme ambient operations. The liquid injection will keep discharge temperatures below 235°F.

If the discharge temperature goes above 255°F, the compressor trips and the controller shows an **E44** error. The compressor cannot turn back on until the discharge line temperature drops below 170°F and has been off for at least 3 minutes.

If the compressor trips more than 4 times in an hour (dLn) on DLT, the controller will lock out the compressor, requiring a manual reset or the controller power to be reset. The controller will display **L44** showing the compressor has tripped on high DLT and is locked out. If parameter dLn, which is available in the advanced options menu, is set to 0, the unit will always automatically reset.

See Section 12 for 86k Thermistor probe resistance values. Discharge line sensor is 86k, all other temperature sensors on this unit are 10k.

6.22.1. Medium Temperature DLT Protection Error Handling

In case of DLT sensor failure, injection is determined by the mid coil and ambient sensor.

If the DLT sensor fails and a mid-coil temperature sensor is available, the injection valve will be opened based on the mid coil temperature. If the mid coil sensor fails in addition to the DLT sensor, the injection is determined by the ambient temperature.

6.23. Over-Current Protection

Current is measured using the two current transducers installed on the controller. If the current exceeds the compressor MCC, the controller will stop the compressor for 3 minutes and signal error **E23**. A separate parameter **MC2** is available to allow adjust the maximum current value down, but not up, in the advanced options menu.

To avoid any fault triggering during the compressor startup period caused by the high inrush current, current sensing is not processed by the controller until 6 seconds after compressor startup.

If the compressor trips more than 5 times in an hour (default) on high current, the controller will lock out the compressor and display an **L23** lockout, requiring a manual reset or the controller power to be reset. If the parameter **oCn**, which is available in the advanced options menu, is set to 0, then the unit will always reset.

6.24. Incorrect Phase Sequence Protection (3 Phase Only)

The controller determines whether the sequence of three phase supply lines is proper or not. The voltage sensing terminals are connected to the 3-phase supply of the compressors. If an incorrect phase (L1, L2, and L3) is detected, the controller will trip compressor immediately and display an **L21** lockout code. The compressor will not restart until the power to the unit is turned off and L1 and L2 are switched. The reset button will not work with this error.

6.25. Loss of Phase Protection - Current (3 Phase Only)

The unit controller detects whether or not all the three phase supplies are available. If a phase is missing, the controller will shut down the compressor and display an **E20** error code and prevent the compressor from restarting for 3 minutes. If the unit is shut down more than 5 times in an hour (default), then unit will lock out and display an **L20** lockout code. If the parameter (**PEn**) is set to 0, the unit will always automatically reset.

6.26. Open Run Circuit (Single Phase Only)

After the compressor is started and runs for 6 seconds, if there is no run circuit current and the start current is still greater than 1 amp, the controller will display an **E24** error for open run circuit and shut down the compressor. The compressor will not restart for 3 minutes in the event of a trip.

If the unit is shut down more than 5 times in an hour (**oCn**), then the unit locks out and display a **L24** lockout code. If the parameter (**oCn**) is set to 0, the unit will always automatically reset.

6.27. Open Start Circuit (Single Phase Only)

Immediately after startup, if there is no start current for the first 500ms and the run current is greater than 1 amp, the controller will display an **E25** error for open start circuit and shut down the compressor. The compressor will not restart for 3 minutes in the event of a trip. If the unit is shut down more than 5 times in an hour (**oCn**), then the units locks out and display an **L25** lockout code. If the parameter (**oCn**) is set to 0, the unit will always automatically reset.

6.28. Over/ Under Voltage Protection

If the voltage drops below 10% of the minimum rated voltage or above 10% of the maximum rated voltage for 1 second, the controller will shut off the compressor and display an **E26** (under voltage) or **E27** (over voltage) error code until the voltage is back within acceptable range and the compressor has been off for 3 minutes (**oCn**).

If the compressor trips more than 5 times per hour (Default), the controller will lock out the compressor, requiring a manual reset or the controller power to be reset. If the parameter (**PEn**) is set to 0, then the unit will always reset. The controller will display an **L26** (lockout, under voltage) or **L27** (lockout over voltage).

6.29. Phase Imbalance (3 Phase Only)

If the voltage in a given leg drops below 5% of the average voltage of the 3 legs for 1 second, the controller will display **E22** and shut the unit down (based on a parameter **PiC**) for 5 minutes and until the phase imbalance is corrected.

6.30. Compressor Internal Thermal Protection

If the compressor's internal thermal protector trips, the contactor fails, or the contactor is miswired, the controller will detect the loss of current and display an **E28** warning code. This happens if both of the current transducers do not sense current for 1 second when the controller sends a compressor run signal. To avoid any fault triggering during the compressor startup period caused by the high inrush current, current sensing is not processed by the controller until 6 seconds after compressor startup.

6.31. Fixed High Pressure Control

The high pressure control is a nonadjustable pressure switch that opens at 440 +/- 10 psig and resets at 348psig in the event of high discharge pressure. If the high pressure switch is open, the compressor shuts off immediately, ignoring any overrides. As long as the high pressure switch is open, the compressor will not run. The compressor will stay off for 3 minutes regardless of when the pressure switch resets. **E40** will be displayed while the unit is shut down.

If the compressor trips more than 5 times per hour, the controller will lock out the compressor, requiring a manual reset or the unit power to be reset. Error code **L40** means the compressor tripped on high pressure and is locked out. If the parameter **HPn** is set to 0, the unit will always automatically reset.

6.32. Alarm Contact

The alarm contact (A1 and A2 on terminal block) is a dry contact that can be wired to an external warning device such as a buzzer or light. This relay has a 5 Amp limit, up to 250V. The alarm contact will close in the event of an alarm or lockout.

6.33. Anti-Flood Back Warning

System Liquid Flood Back Warning Logic:

High-side superheat is the discharge line temperature minus the mid-coil temperature. If high-side superheat is less than 18°F for longer than 30 minutes during the last 45 minutes, the controller will display **E50**, but continue running the system. When the high-side superheat climbs above 18°F for 30 minutes, then the warning signal stops.

6.34. High Condensing Temperature Warning

An **E46** warning means the condensing temperature exceeded 150°F. The fans will run at full speed but the compressor does not shut down. The warning clears when the temperature drops below 140°F.

7. Local and Remote Displays and Communication

The controller can communicate with Modbus RTU RS485 supervisory controllers. An optional remote display is available. The display can be mounted up to 30 feet from the unit. To connect and configure the remote display, follow the instructions included with the remote display

8. Physical and Installation Requirements

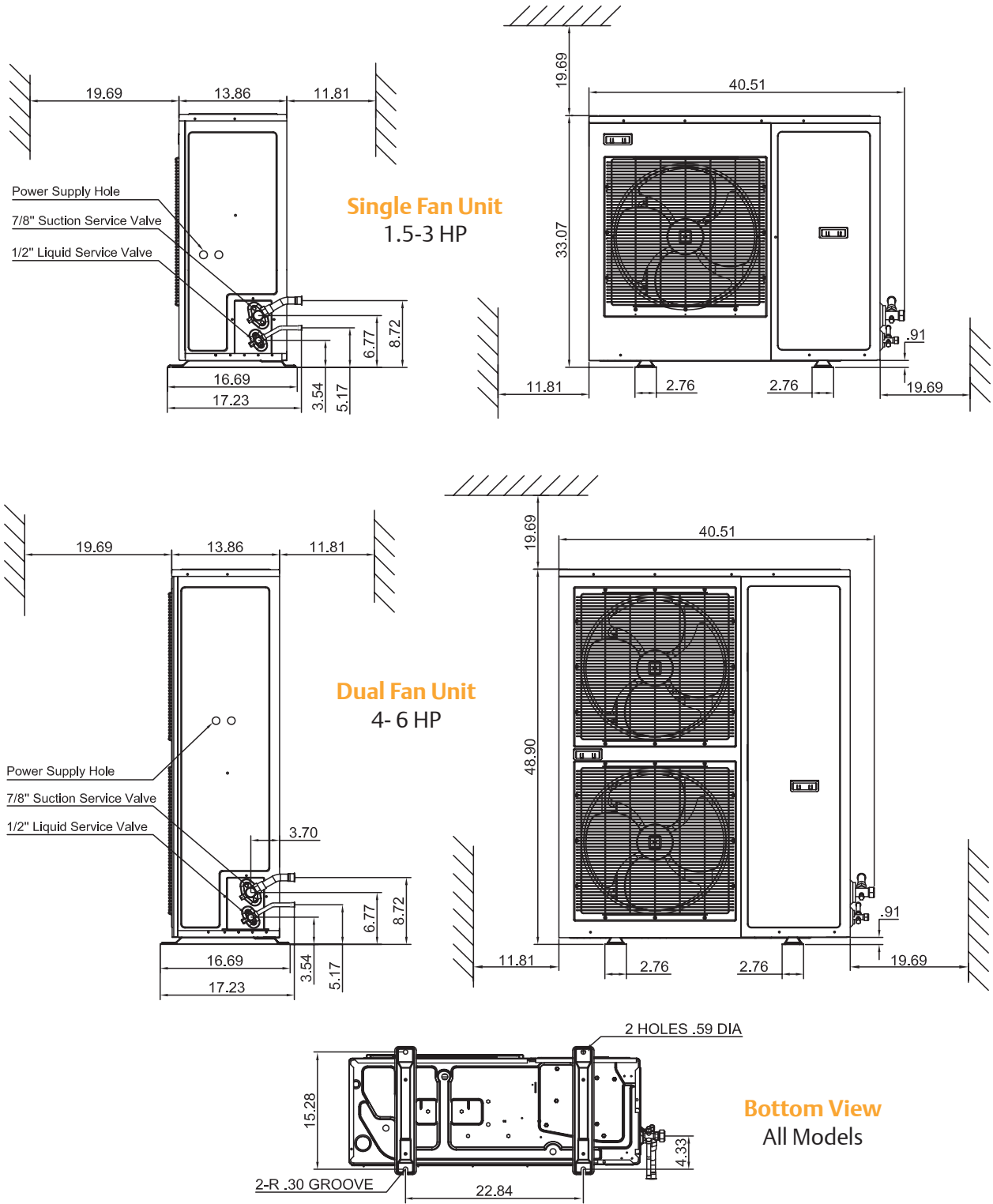

Figure 1

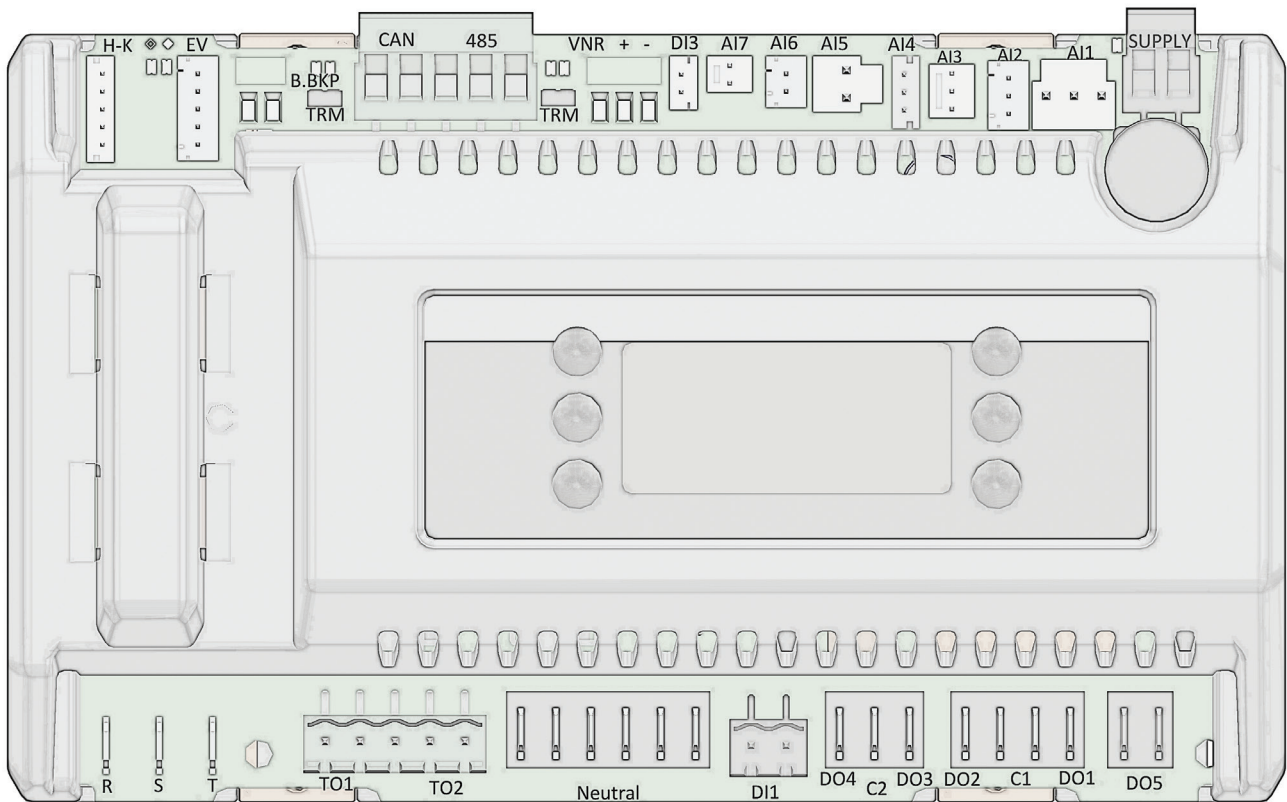

Figure 2 – Controller

NOTE: There is no field wiring to this controller except for communications. The transformer wired in the unit is for the controller only. Do not tap off the transformer to power any other devices. When removing a connector, do not pull on the wire.

High Voltage Connections

Label	Connector(s)	Electrical Limit (250VAC Max)	Function
C1	¼" Spade Connectors (2)	25A Max Current (16A Max Each Spade)	Provides Power for Defrost Heater and Evaporator Fan Relays
D01	¼" Spade Connector	16A Relay	Operates 40A Evaporator Fan Relay
D02	¼" Spade Connector	16A Relay	Operates 40A Defrost Heater Relay
C2	¼" Spade Connector	16A Max Current	Provides Power to Compressor Relay and CCH/RH Relays
D03	¼" Spade Connector	5A Relay	Operates Compressor Contactor
D04	¼" Spade Connector	8A Relay	Powers Crankcase Heater and Receiver Heater
D05	¼" Spade Connectors (2)	5A Relay	Dry (Switch Only) Alarm Contact
DI1		250VAC Max	Left Terminal – Defrost Termination Input Right Terminal – L2

High Voltage Connections (continued)

Label	Connector(s)	Electrical Limit (250VAC Max)	Function
Neutral	1/4" Spade Connectors (6)	25A Max Current (16A Max Each Spade)	L1 Common Terminal Strip
R	1/4" Spade Connector	480V Max	L1 Voltage Sensing
S	1/4" Spade Connector	480V Max	L2 Voltage Sensing
T	1/4" Spade Connector	480V Max	L3 Voltage Sensing (3 Phase Only)
SUPPLY		24VAC, 40VA	Controller Power Supply
T01		2A Wave Form Chopping Triac	Variable Speed PSC Fan Motor Control
T02		Not Used	For Future Use

Sensor Connections

Label	Function	Type
A11	Suction Pressure Transducer	0.5 to 4.5 VDC Ratio metric
A12	Condenser Temperature Sensor	10k NTC (See Section 12 for values)
A13	Discharge Line Temperature Sensor	86k NTC (See Section 12 for values)
A14	EVI Heat Exchanger Inlet Vapor Temperature Sensor (Low Temp Only)	10k NTC (See Section 12 for values)
A15	EVI Heat Exchanger Outlet Vapor Temperature Sensor (Low Temp Only)	10k NTC (See Section 12 for values)
A16	Ambient Temperature Sensor	10k NTC (See Section 12 for values)
A17	Liquid Line Temperature Sensor (Low Temp Only)	10k NTC (See Section 12 for values)
D13	Future Use	Future Use
EV	Liquid or Vapor Injection Valve	12VDC Stepper

Other Connections

Label	Functions
VNR	Remote Display Connection
Connect + to + and – to -	
RS485	RS-485 Communications
CANBUS	Future Use
B.BKP	Future Use
H-K	Hotkey programming (use with part # 043-0171-01 to reset control)

9. Wiring Diagrams

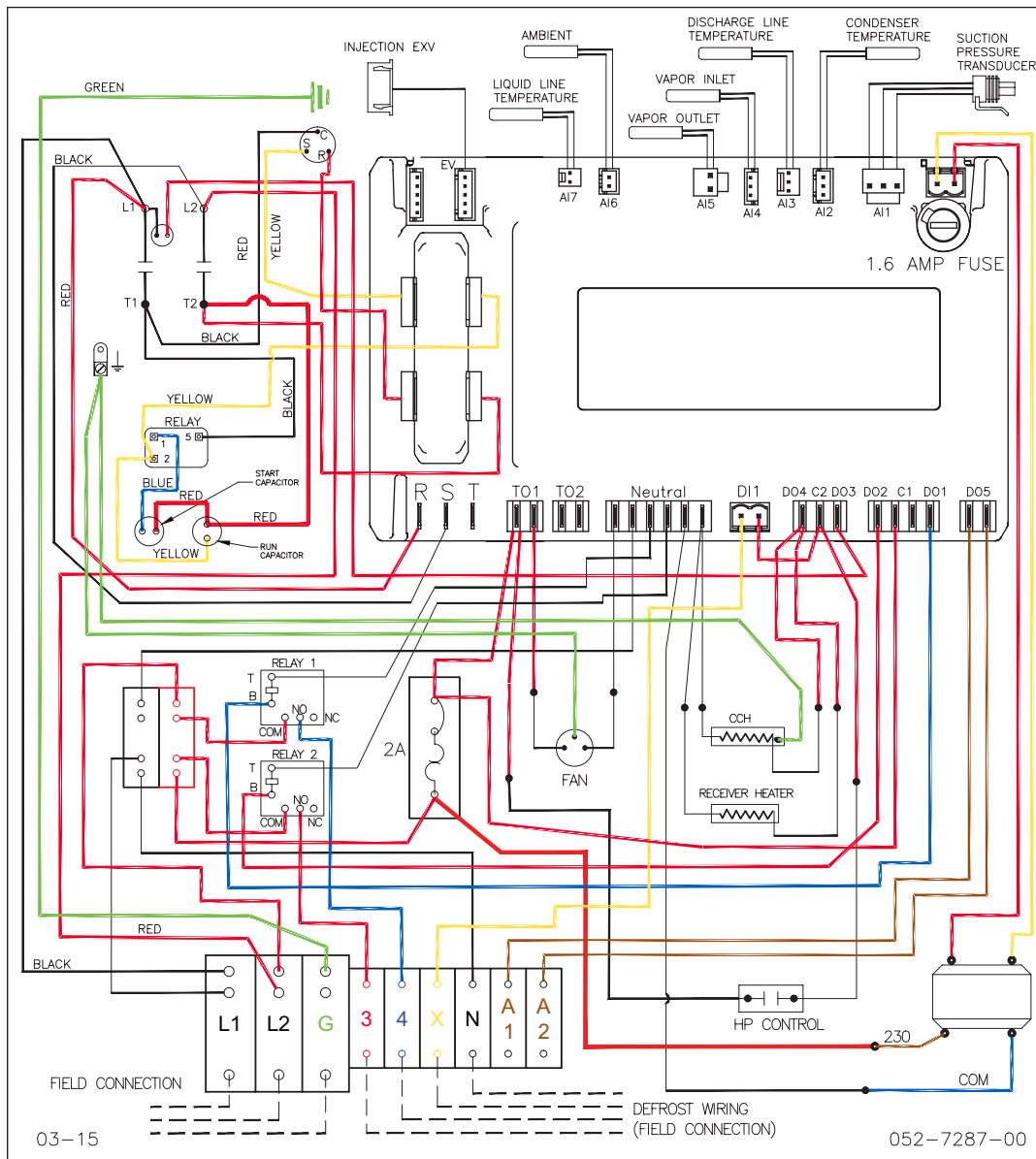

052-7287-00
Low Temp 1-Phase 2.0-3.5 HP
1 Condenser Fan

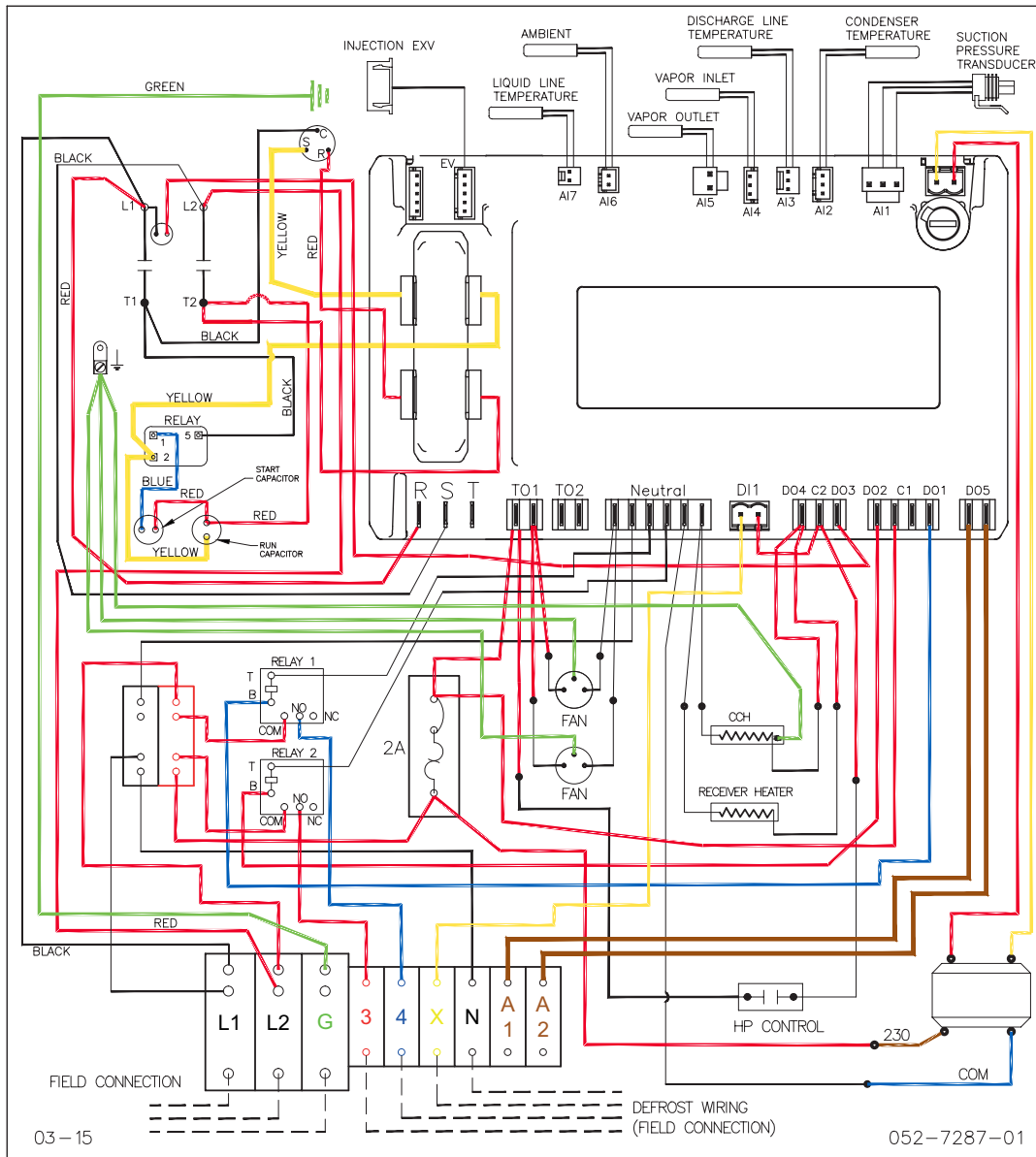

052-7287-01
Low Temp 1-Phase 4-5 HP
2 Condenser Fans

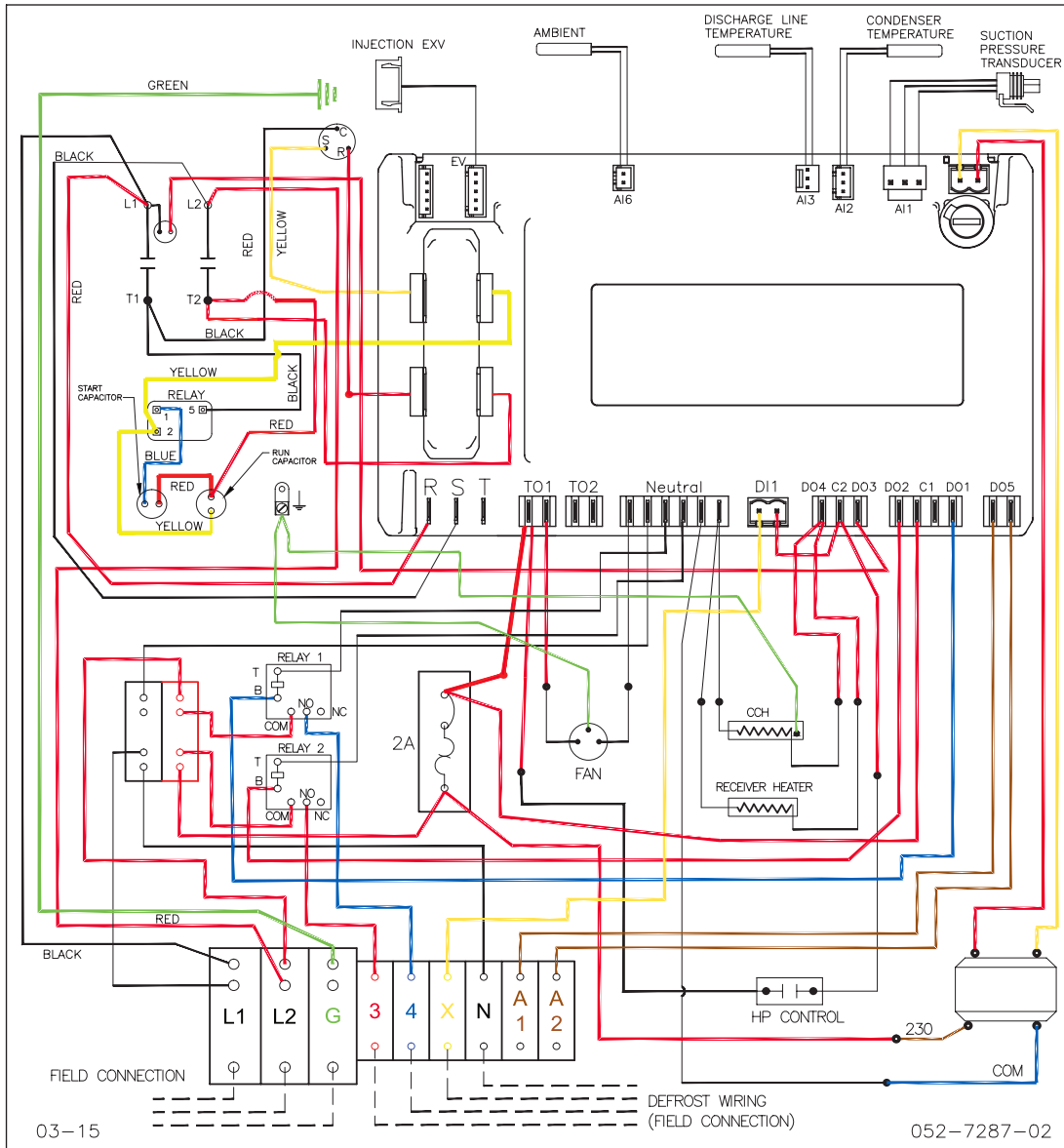

052-7287-02
Medium Temp 1-Phase 1.5-3 HP
1 Condenser Fan

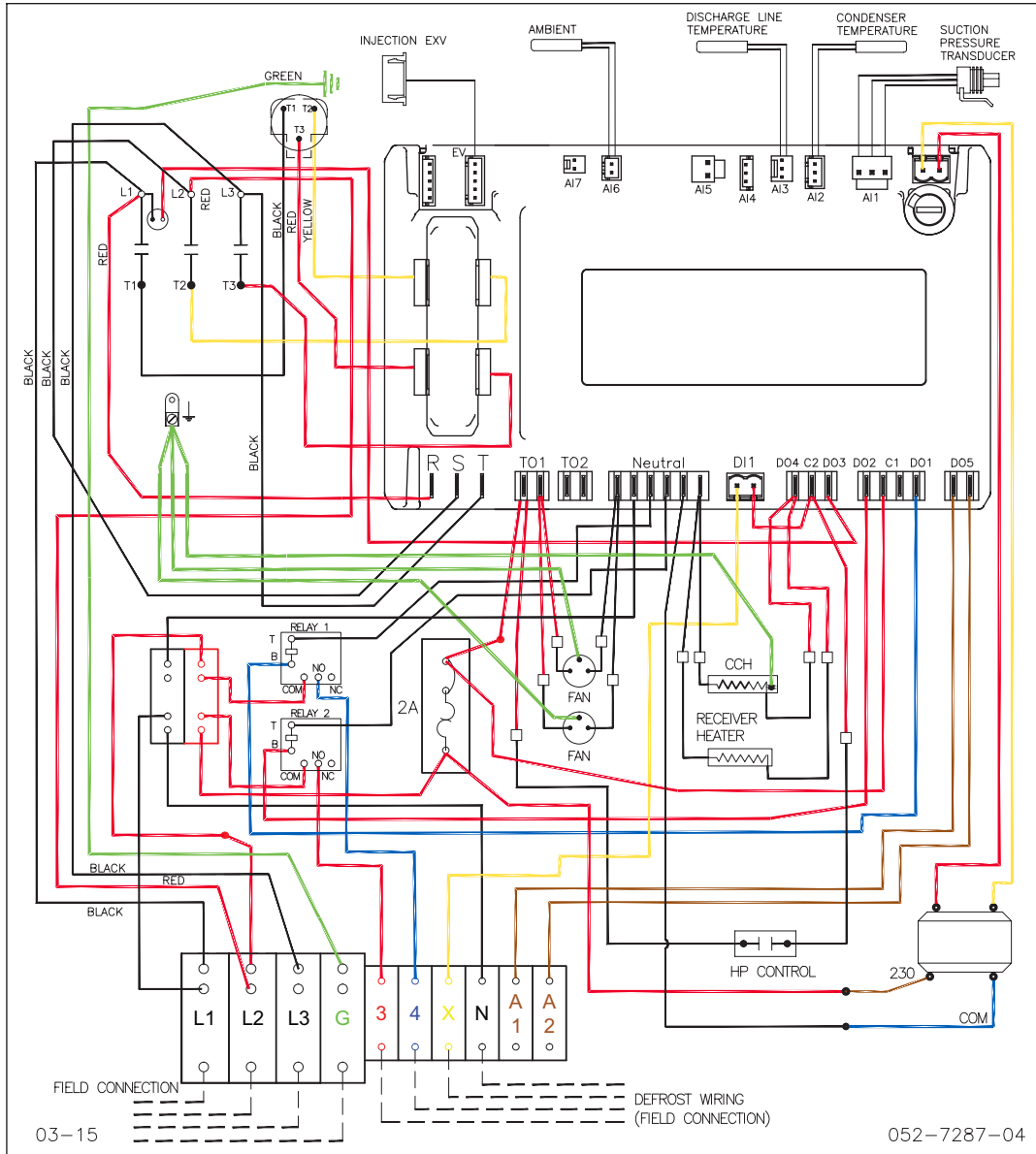

052-7287-04
Medium Temp 3-Phase 4.5-6 HP
2 Condenser Fans

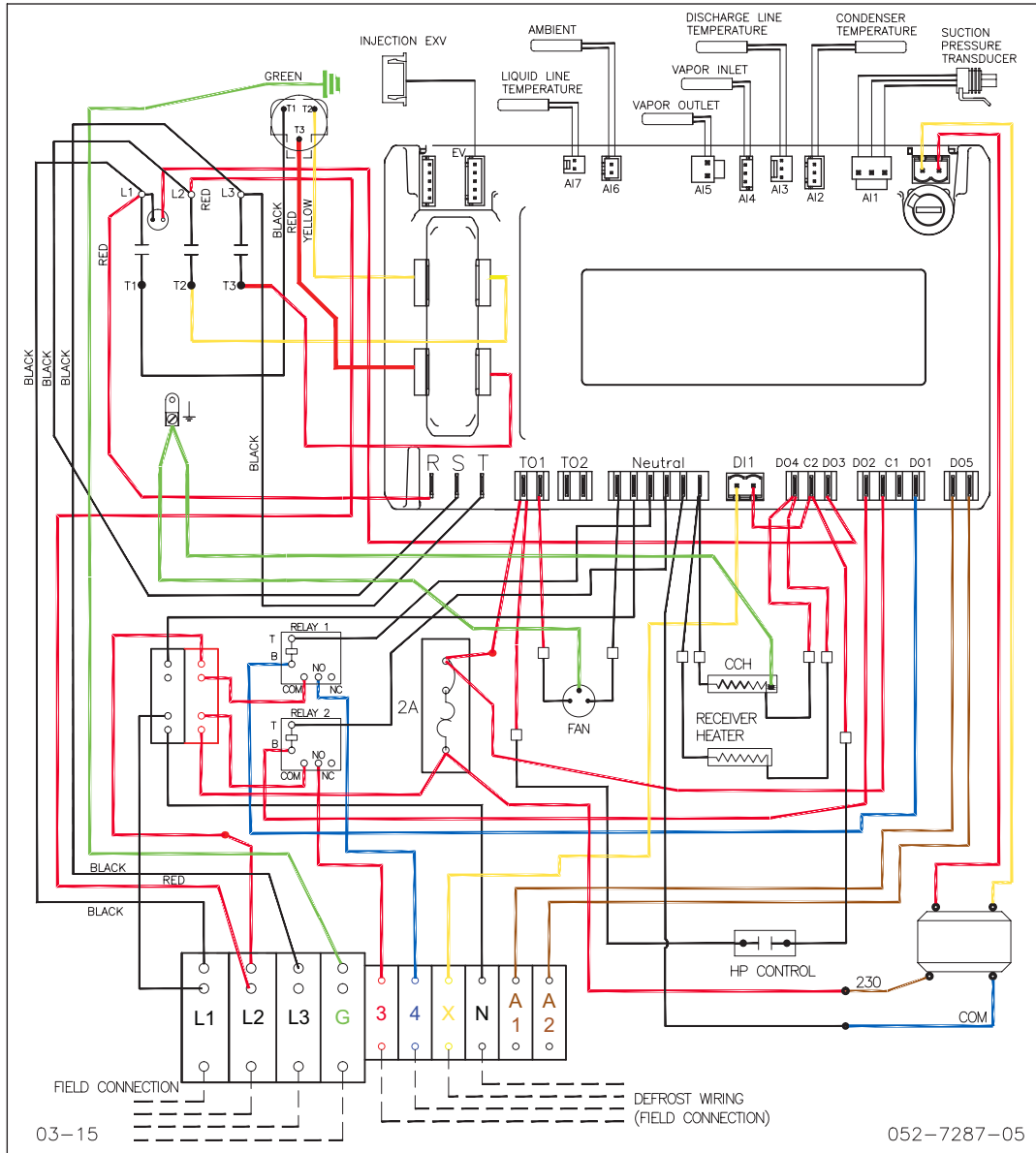

052-7287-05
Low Temp 3-Phase 2-3 HP
1 Condenser Fans

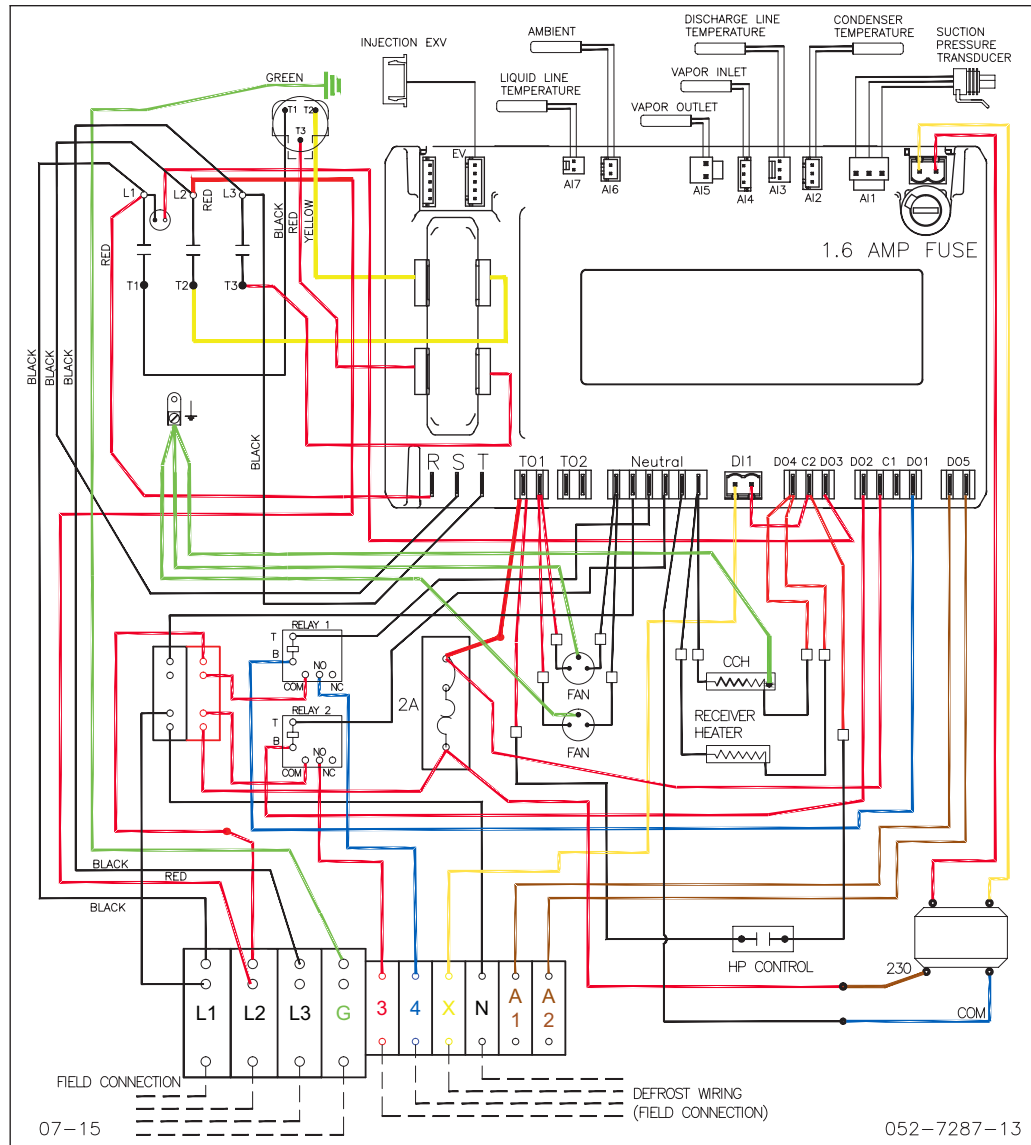

052-7287-13
Low Temp 3-Phase 4-6 HP
2 Condenser Fans

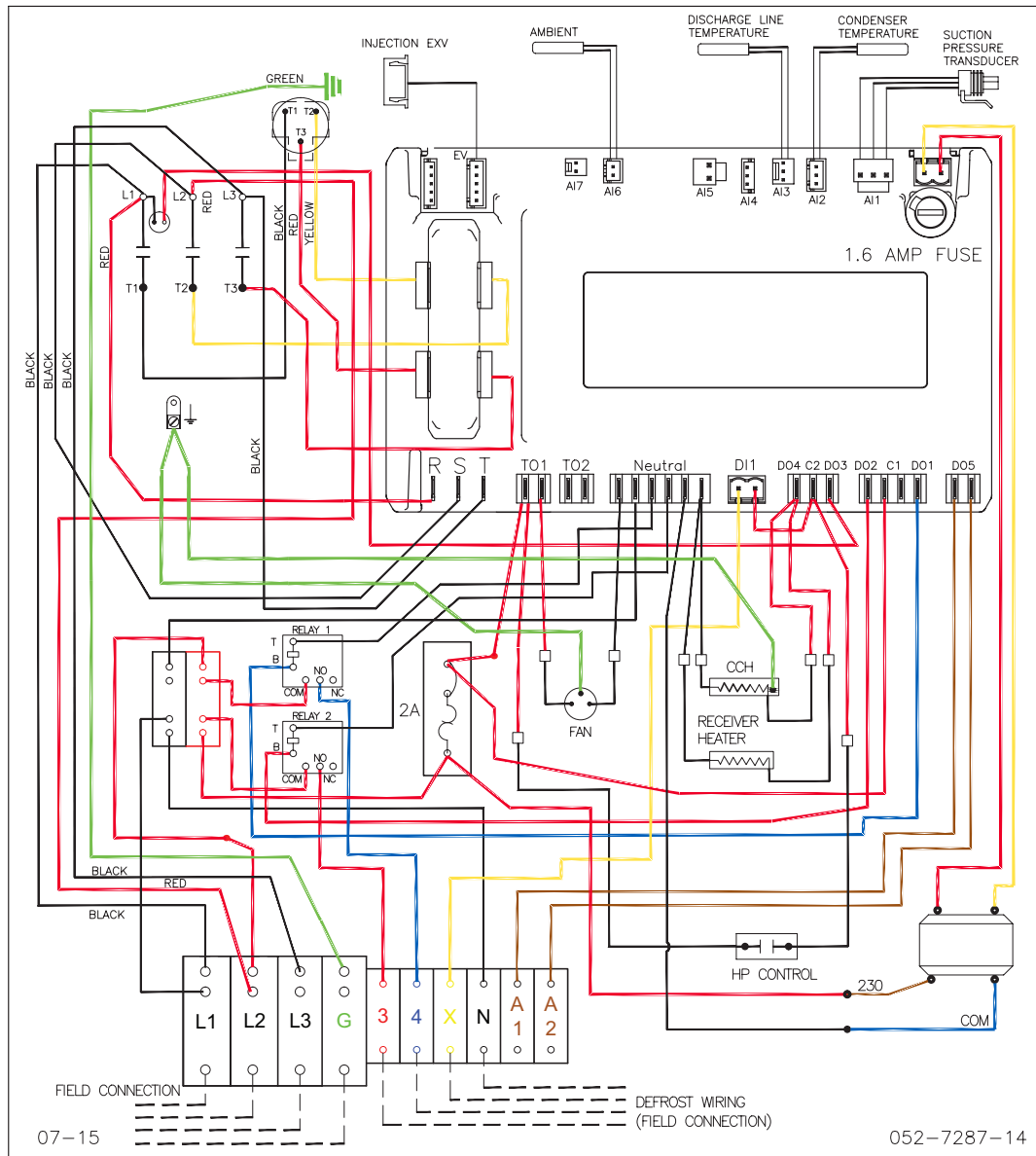

052-7287-14
Medium Temp 3-Phase 1.5-3 HP
1 Condenser Fan

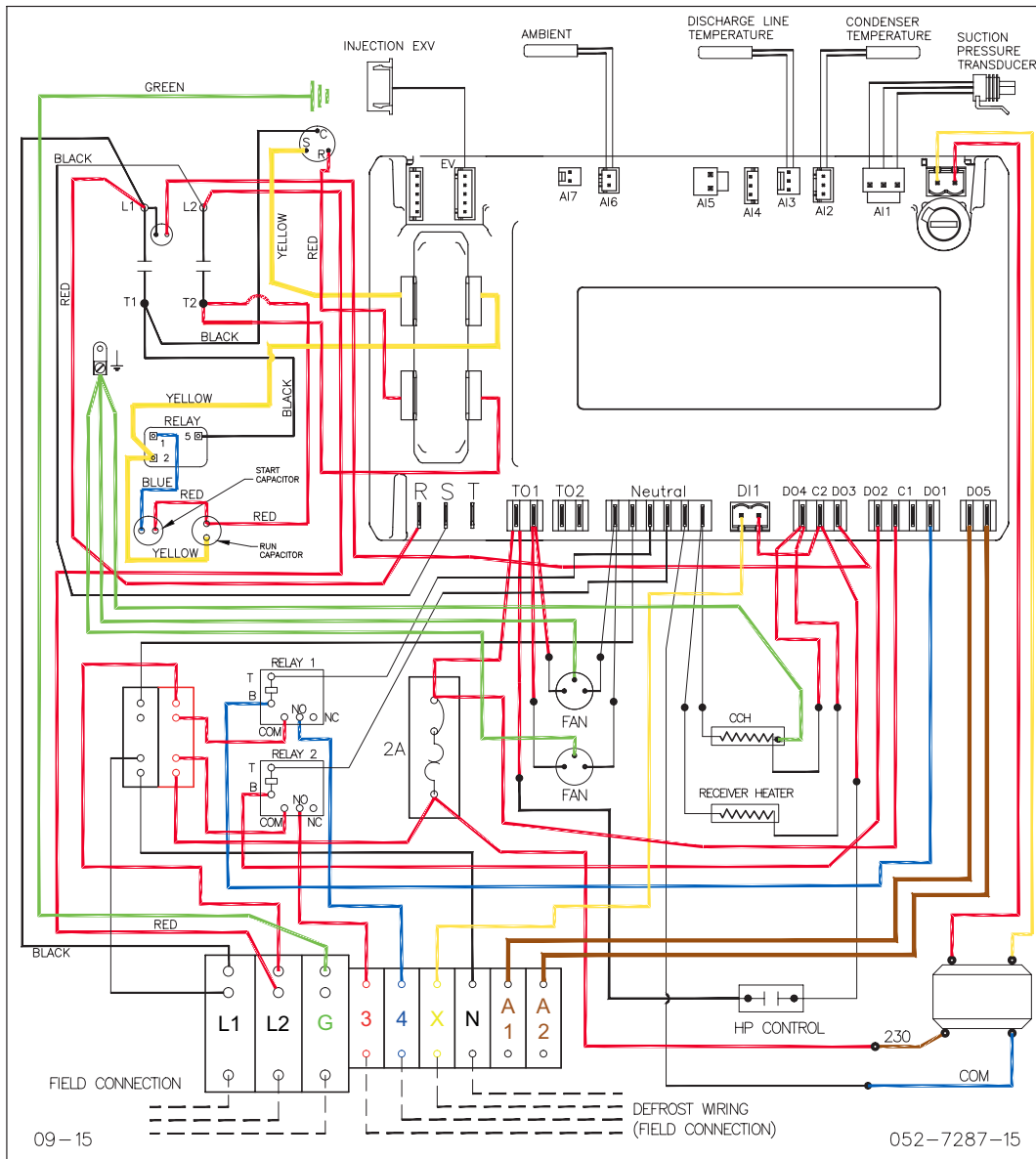

052-7287-15
Medium Temp 1-Phase 4.5-5 HP
2 Condenser Fans

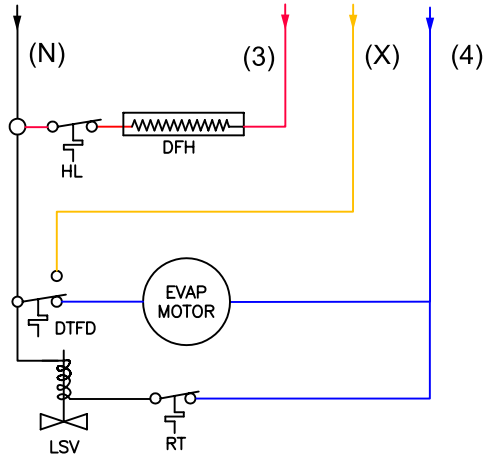

**Evaporator Wiring
Typical Unit Cooler**

10. Refrigerant Liquid Temperature Valve Capacity Multiplier Correction Factors

	Refrigerant Liquid Temperature Entering TXV														
	0	10	20	30	40	50	60	70	80	90	100	110	120	130	140
R-22	1.56	1.51	1.45	1.40	1.34	1.29	1.23	1.17	1.12	1.06	1.00	0.94	0.88	0.82	0.76
R-404A	2.00	1.90	1.80	1.70	1.60	1.50	1.40	1.30	1.20	1.10	1.00	0.90	0.80	0.70	0.50
R-507	2.00	1.90	1.80	1.70	1.60	1.50	1.40	1.30	1.20	1.10	1.00	0.90	0.80	0.70	0.50
R-134a	1.70	1.63	1.56	1.49	1.42	1.36	1.29	1.21	1.14	1.07	1.00	0.93	0.85	0.78	0.71
R-407A	1.75	1.68	1.61	1.53	1.46	1.39	1.31	1.24	1.16	1.08	1.00	0.92	0.84	0.76	0.68
R-407C	1.69	1.62	1.55	1.49	1.42	1.35	1.28	1.21	1.14	1.07	1.00	0.93	0.86	0.79	0.72

These factors include corrections for liquid refrigerant density and net refrigerating effect and are based on an average evaporator temperature of 0°F. However, they may be used for any evaporator temperature from - 40°F to + 40°F since the variation in the actual factors across this range is insignificant.

11. Alarm Codes

Code	Description	Alarm Level	Diagnostic Resolution	Possible Fix
E01	Suction pressure transducer error	Alarm	Check wire connection to the top of the controller (A1) Check to ensure suction pressure is below 135 PSIG	Replace faulty suction pressure transducer
E02	Condenser temperature sensor error	Alarm	Check wire connection to the top of the controller (A2)	Replace faulty temperature sensor
E03	Discharge line temperature sensor error	Alarm	Check wire connection to the top of the controller (A3)	Replace faulty temperature sensor
E04	EVI heat exchanger vapor inlet temperature error (XFALs only)	Alarm	Check wire connection to the top of the controller (A4)	Replace faulty temperature sensor
E05	EVI heat exchanger vapor outlet temperature error (XFALs only)	Alarm	Check wire connection to the top of the controller (A5)	Replace faulty temperature sensor
E06	Ambient temperature sensor error	Alarm	Check wire connection to the top of the controller (A6)	Replace faulty temperature sensor
E07	Liquid line temperature sensor error (XFALs only)	Alarm	Check wire connection to the top of the controller (A7)	Replace faulty temperature sensor
E09-E10	Current sensor error	Alarm	Check wires are properly routed through controller current transducers per wiring diagram	Replace faulty controller
E11-E13	Voltage sensor error	Alarm	Check wires are connected to voltage sensing connections (R, S, T) per wiring diagram	Replace faulty controller
E20 L20	Lost phase error/ lockout (Three phase only)	Alarm Lockout	Check power to unit	Check wires are connected to voltage sensing connections (R, S, T) per wiring diagram
E21 L21	Phase sequence error / lockout (Three phase only)	Alarm Lockout	Reverse two phases incoming power to unit	Check wires are connected to voltage sensing connections (R, S, T) per wiring diagram
E22	Phase imbalance (Three phase only)	Alarm	Check incoming electrical power	Correct incoming voltage supply
E23 L23	Over current error/ lockout	Alarm Lockout	Confirm system operation to find out what is causing the compressor to pull excessive current	
E24 L24	Open run circuit error/ lockout	Alarm Lockout	Check run capacitor	Check start component wiring per diagram Check wires are properly routed through controller current transducers per wiring diagram

Code	Description	Alarm Level	Diagnostic Resolution	Possible Fix
E25 L25	Open start circuit error/ lockout	Alarm Lockout	Check start capacitor	Check start component wiring per diagram Check wires are properly routed through controller current transducers per wiring diagram
E26 L26	Under voltage alarm/ lockout	Alarm Lockout	Check incoming power	
E27 L27	Over voltage alarm/ lockout	Alarm Lockout	Check incoming power	
E28	Compressor protector trip	Warning	Check to see if compressor is tripped on protector	Check to see if contactor is functioning properly Check contractor control circuit wiring per wiring diagram
E40 L40	High pressure switch trip/ lockout	Alarm Lockout	Check system cause of high pressure trip Check if circuit breaker is tripped (It provides power to the high pressure switch)	Ensure wiring to terminal C2 of the controller is correct per the wiring diagram and C2 is receiving power. Verify high pressure switch is working properly or needs replaced
E44 L44	Discharge line temperature alarm/ lockout	Alarm Lockout	Check system cause of high DLT	Faulty temperature sensor. Check sensor values versus section 12.
E46	High condenser temperature alarm	Alarm	Check to see what is causing the system to run at a higher condensing temperature	Faulty temperature sensor. Check sensor values versus section 12.
E47	Over injection (XFALs only)	Warning		
E48	Refrigerant shortage (XFALs only)	Warning	Check refrigerant charge	EVI injection valve may not be clogged or blocked
E50	High side flood back alarm	Warning	Check to see if proper superheat is being maintained	
E80	Rtc warning, date not correct	Warning	Set the real time clock	
E81	Rtf warning, communication error	Warning	Reload factory settings with the hotkey and reset the real time clock	Replace faulty controller
E82-E85	Configuration Errors	Alarm	Reload factory settings with the hotkey	Replace faulty controller
L86	EEPROM Memory Error	Lockout	Reload factory settings with the hotkey	Replace faulty controller

12. Sensor Values

Discharge Line
Temperature Sensor Resistance

°F	Resistance (kOhms)
-40	2889.60
-31	2087.22
-22	1522.20
-13	1121.44
-4	834.72
5	627.28
14	475.74
23	363.99
32	280.82
41	218.41
50	171.17
59	135.14
68	107.44
77	86.00
86	69.28
95	56.16
104	45.81
113	37.58
122	30.99
131	25.68
140	21.40
149	17.91
158	15.07
167	12.73
176	10.79
185	9.20
194	7.87
203	6.77
212	5.85
221	5.09
230	4.45
239	3.87
248	3.35
257	2.92
266	2.58
275	2.28
284	2.02
293	1.80
302	1.59
311	1.39
320	1.25
329	1.12
338	1.01
347	0.92
356	0.83

Temperature Sensor Resistance
(Excludes DLT)

°F	Resistance (kOhms)
-55	302.2
-50	254.9
-45	221.7
-40	188.5
-35	160.2
-30	140.4
-25	120.2
-20	105.7
-15	90.8
-10	80.3
-5	69.4
0	61.5
5	53.4
10	46.5
15	41.5
20	36.3
25	32.4
30	28.5
35	25.6
40	22.5
45	20.3
50	18.0
55	15.9
60	14.4
65	12.8
70	11.6
75	10.4
80	9.46
85	8.47

°F	Resistance (kOhms)
90	7.73
95	6.94
100	6.25
105	5.73
110	5.17
115	4.75
120	4.30
125	3.96
130	3.59
135	3.32
140	3.02
145	2.75
150	2.55
155	2.33
160	2.16
165	1.98
170	1.84
175	1.69
180	1.58
185	1.45
190	1.34
195	1.25
200	1.15
205	1.08
210	0.998
215	0.937
220	0.868
225	0.816
230	0.758

13. Parameters

Label	Description	Default	Range
Default Display Value			
	Current Suction Pressure (PSIG)		
Adjustable in Programming Menu			
Compressor			
Cin / $\bar{C}in$	Compressor cut in pressure set point (PSIG)	25.0	Cou - 135
CoU / $\bar{C}oU$	Compressor cut out pressure set point (PSIG)	15.0	0 - Cin
rEF / $\bar{r}EF$	Refrigerant Selection for Regulation	R404A	All unit Refs
Low Side Control			
idF / $\bar{i}dF$	interval between defrost cycles (hour)	8	0 - 120
MdF / $\bar{M}dF$	Maximum length for defrost (min)	45	0 - 255
EdF / $\bar{E}dF$	Defrost interval mode	in	nu, in, RTC
Ld1 / $\bar{L}d1$	Workday defrost start 1 (hour)	6:00	nu, 0:00 - 23:50
Ld2 / $\bar{L}d2$	Workday defrost start 2 (hour)	13:00	nu, 0:00 - 23:50
Ld3 / $\bar{L}d3$	Workday defrost start 3 (hour)	21:00	nu, 0:00 - 23:50
Ld4 / $\bar{L}d4$	Workday defrost start 4 (hour)	nu	nu, 0:00 - 23:50
Ld5 / $\bar{L}d5$	Workday defrost start 5 (hour)	nu	nu, 0:00 - 23:50
Ld6 / $\bar{L}d6$	Workday defrost start 6 (hour)	nu	nu, 0:00 - 23:50
Real Time Clock			
Min / $\bar{M}in$	Current minute		0 - 59
Hr / $\bar{H}r$	Current hour		0 - 23
MdY / $\bar{M}dY$	day of month		1 - 31
Mon / $\bar{M}on$	month		1 - 12
YEr / $\bar{Y}Er$	year		0 - 99
Password			
PAS / $\bar{P}AS$	Enter into PR2 level	321	(blank)
Adjustable from Advanced Options Menu			
Probe Configuration			
P1F / $\bar{P}1F$	Probe P1 calibration (PSIG)	0.0	-12.0 - 12.0
Display			
Lod / $\bar{L}od$	Remote Display visualization	P1	P1 - P7
Compressor			
LAS / $\bar{L}AS$	Ambient temperature required to initiate low ambient on time (°F)	-20	-40 - 230
LMO / $\bar{L}MO$	Low ambient minimum on time (sec)	6	0 - 255



Label	Description	Default	Range
Compressor Safety			
odS / odS	Output delay at start up (sec)	6	0 - 255
Con / Con	Compressor On time with faulty probe (min)	3	0 - 255
CoF / CoF	Compressor OFF time with faulty probe (min)	3	0 - 255
2oF / 2oF	Compressor Minimum Off Time (sec)	120	1 - 900
HPn / HPn	Number of high pressure switch activation before compressor lock	5	0 - 15
bMP / bMP	Bump start enable	YES	no, yes
dLn / dLn	Number of activation of DLT in a hour to lock compressor	4	0 - 15
Condenser Fan			
MCS / MCS	Minimum Condenser set point (°F)	70 - XFAP 80 - XFAL	-40 - 230
Low Side Control			
dFd / dFd	Display during defrost	dEF	DEF, Setpoint, Initial Pressure, End Pressure
Fdt / Fdt	Drip time (min)	0	0 - 120
dPo / dPo	Defrost at power-on	NO	no, yes
Sd1 / Sd1	Holiday defrost start 1 (hour)	6:00	nu, 0:00 - 23:50
Sd2 / Sd2	Holiday defrost start 2 (hour)	13:00	nu, 0:00 - 23:50
Sd3 / Sd3	Holiday defrost start 3 (hour)	21:00	nu, 0:00 - 23:50
Sd4 / Sd4	Holiday defrost start 4 (hour)	nu	nu, 0:00 - 23:50
Sd5 / Sd5	Holiday defrost start 5 (hour)	nu	nu, 0:00 - 23:50
Sd6 / Sd6	Holiday defrost start 6 (hour)	nu	nu, 0:00 - 23:50
Hd1 / Hd1	First Weekly holiday	nu	Sun - Sat
Hd2 / Hd2	second weekly holiday	nu	Sun - Sat
FnC / FnC	Fans operating mode	on	cn, on, cy, oy
Compressor Protection			
MC2 / MC2	Adjustable current limit before trip (Amps)	MCA	0 - MCA
oCn / oCn	Over Current Trips before lockout	5	0 - 15; 0 = always automatic restart
PEn / PEn	loss of phase trips number before lockout	5	0 - 15; 0 = always automatic restart
Utn / Utn	compressor trips before lockout	5	0 - 15; 0 = always automatic restart
PiC / PiC	Generate warning or shut the regulation when phase imbalance	Trip	Warning, Trip
Serial Address			
Adr / Adr	Serial address	1	1 - 247

The contents of this publication are presented for informational purposes only and are not to be construed as warranties or guarantees, express or implied, regarding the products or services described herein or their use or applicability. Emerson Climate Technologies, Inc. and/or its affiliates (collectively "Emerson"), as applicable, reserve the right to modify the design or specifications of such products at any time without notice. Emerson does not assume responsibility for the selection, use or maintenance of any product. Responsibility for proper selection, use and maintenance of any Emerson product remains solely with the purchaser or end user.