

Bosch BVA Series Air Handler

2-3-4-5 Ton Capacity

R410A



BOSCH

Installation Instructions



Table of Contents

1. SAFETY	2
2. GENERAL	3
3. APPLICATIONS	5
4. ELECTRICAL WIRING	7
5. AIRFLOW PERFORMANCE	9
6. DUCTWORK	10
7. REFRIGERANT CONNECTIONS	10
8. AIR FILTER (not factory-installed)	11
9. FILTER INSTALLATION DIMENSIONS	12
10. WIRING	13

Explanation Of Symbols

Warnings



Warnings in this document are identified by a warning triangle printed against a grey background. Keywords at the start of a warning indicate the type and seriousness of the ensuing risk if measures to prevent the risk are not taken.

The following keywords are defined and can be used in this document:

- ▶ **DANGER** indicates a hazardous situation which, if not avoided, will result in death or serious injury.
- ▶ **WARNING** indicates a hazardous situation which, if not avoided, could result in death or serious injury.
- ▶ **CAUTION** indicates a hazardous situation which, if not avoided, could result in minor to moderate injury.
- ▶ **NOTICE** is used to address practices not related to personal injury.

Important information



Important information in cases where there is no risk of personal injury or material losses is identified by the symbol shown on the left. It is bordered by horizontal lines above and below the text.



DANGER:

- These instructions are intended as an aid to qualified licensed service personnel for proper installation, adjustment and operation of this unit. Read these instructions thoroughly before attempting installation or operation. Failure to follow these instruction may result in improper installation, adjustment, service or maintenance possibly resulting in fire, electrical shock, property damage, personal injury or death.

This document is customer property and is to remain with this unit. These instructions do not cover all the different variations systems nor does it provide for every possible contingency to be met in connection with installation.

All phases of this installation must comply with NATIONAL STATE AND LOCAL CODES. If additional information is required please contact your local distributor.

1. SAFETY

	WARNING
<p>Disconnect all power to unit before installing or servicing. More than one disconnect switch may be required to de-energize the equipment. Hazardous voltage can cause severe personal injury or death.</p>	

	WARNING
<p>If removal of the blower assembly is required, all disconnect switches supplying power to the equipment must be de-energized and locked (if not in sight of unit) so the field power wires can be safely removed from the blower assembly. Failure to do so can cause electrical shock resulting in personal injury or death.</p>	

	WARNING
<p>Because of possible damage to equipment or personal injury, installation, service, and maintenance should be performed by a trained, qualified service personnel. Consumer service is recommended only for filter cleaning / replacement. Never operate the unit with the access panels removed.</p>	

	WARNING
<p>These instructions are intended as an aid to qualified, licensed service personnel for proper installation, adjustment and operation of this unit. Read these instructions thoroughly before attempting installation or operation. Failure to follow these instructions may result in improper installation, adjustment, service or maintenance possibly resulting in fire, electrical shock, property damage, personal injury or death.</p>	

	WARNING
<p>The unit must be permanently grounded. Failure to do so can result in electrical shock causing personal injury or death.</p>	

	WARNING
<p>PROPOSITION 65: This appliance contains fiberglass insulation. Respirable particles of fiberglass are known to State of California to cause cancer.</p> <p>All manufacturer products meet current federal OSHA Guidelines for safety. California Proposition 65 warnings are required for certain products, which are not covered by the OSHA standards.</p> <p>California's Proposition 65 requires warnings for products sold in California that contain or produce any of over 600 listed chemicals known to the State of California to cause cancer or birth defects such as fiberglass insulation, lead in brass, and combustion products from natural gas.</p> <p>All "new equipment" shipped for sale in California will have labels stating that the product contains and /or produces Proposition 65 chemicals. Although we have not changed our processes, having the same label on all our products facilitates manufacturing and shipping. We cannot always know "when, or if" products will be sold in the California market.</p> <p>You may receive inquiries from customers about chemicals found in, or produced by, some of our heating and air-conditioning equipment, or found in natural gas used with some of our products. Listed below are those chemicals and substances commonly associated with similar equipment in our industry and other manufacturers.</p> <ul style="list-style-type: none">Glass Wool (Fiberglass) InsulationCarbon Monoxide (CO).FormaldehydeBenzene <p>More details are available at the websites for OSHA (Occupational Safety and Health Administration), at www.osha.gov and the State of California's OEHHA (Office of Environmental Health Hazard Assessment), at www.oehha.org. Consumer education is important since the chemicals and substances on the list are found in our daily lives. Most consumers are aware that products present safety and health risks, when improperly used, handled and maintained.</p>	



CAUTION

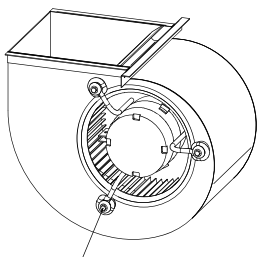

Make sure the blower motor support is tight(3-motor mount bolts) then check to see if wheel is secured to motor shaft before operating unit.

BLOWER MOTOR SHIPPING BOLT



WARNING

The first 6 inches of supply air plenum and ductwork must be constructed of sheet metal as required by NFPA 90B. The supply air plenum or duct must have a solid sheet metal bottom directly under the unit with no openings, registers or flexible air ducts located in it. If flexible supply air ducts are used they may be located only in the vertical walls of rectangular plenum, a minimum of 6 inches from the solid bottom. Metal plenum or duct may be connected to the combustible floor base, if not, it must be connected to the unit supply duct exposed to the supply air opening from the downflow unit. Exposing combustible (non-metal. material to the supply opening of a downflow unit can cause a fire resulting in property damage, personal injury or death.

Exception warning to downflow:

Installations on concrete floor slab with supply air plenum and ductwork completely encased must be not less than 2 inches of concrete (See NFPA 90A).

2. GENERAL

The unit can be positioned for bottom return air in the upflow position, left and right return in the horizontal position, top return in downflow position.

This Air Handler provides the flexibility for installation in any upflow or downflow horizontal application. The direct drive motors provides a selection of air volume to match any application. 5-Speed motors provide selections of air flow to meet desired applications.

Top and side power and control wiring, accessible screw terminals for control wiring all combine to make the installation easy, and minimize installation cost. See fig.1.

To ensure the proper installation, select a solid and level site. Ensure enough space maintained for installation and maintenance.

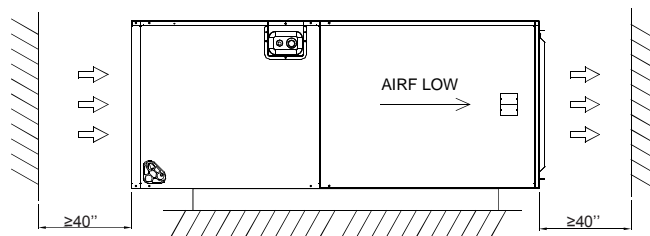

Clearances in the Horizontal Position

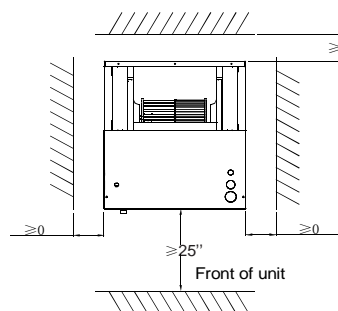

Clearances in the Vertical Position

2.1 UNIT DIMENSIONS

NOTE: 25" CLEARANCE IS REQUIRED IN THE FRONT OF THE UNIT FOR FILTER AND COIL MAINTENANCE.

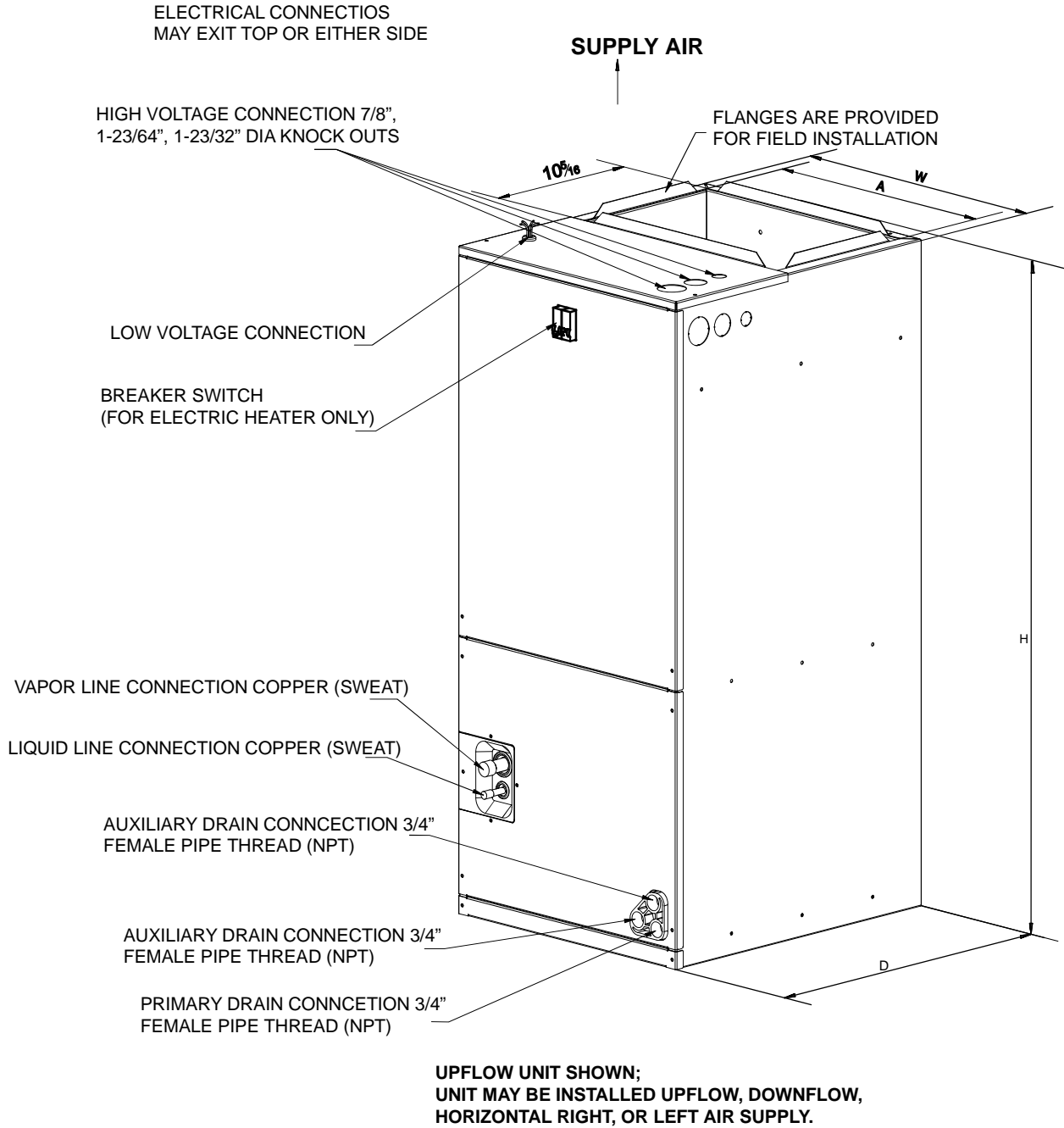

Fig.1 DIMENSIONS

DIMENSIONAL DATA

MODEL SIZE	Dimensions inch [mm]				
	UNIT HEIGHT "H" IN. [mm]	UNIT WIDTH "W" IN. [mm]	UNIT LENGTH "D" IN. [mm]	SUPPLY DUCT "A"	LIQUID LINE / VAPOR LINE
24	46-1/2"[1180]	19-5/8"[500]	21-5/8"[550]	18"[456]	3/8" / 3/4" [9.5]/[19]
36	54-1/2"[1385]	22"[560]	24"[610]	19-1/2"[496]	3/8" / 3/4" [9.5]/[19]
48	54-1/2"[1385]	22"[560]	24"[610]	19-1/2"[496]	3/8" / 7/8" [9.5]/[22]
60	54-1/2"[1385]	22"[560]	24"[610]	19-1/2"[496]	3/8" / 7/8" [9.5]/[22]

3 APPLICATIONS

3.1 VERTICAL UPFLOW

- Vertical Upflow configuration is the factory set on all models (see Fig 1).
- If return air is to be ducted, install duct flush with floor. Use fireproof resilient gasket 1/8 to 1/4 in. thick between the ducts, unit and floor. Set unit on floor over opening.

IMPORTANT NOTE

Torque applied to drain connections should not exceed 15.ft.lbs.(see Fig.1&2)

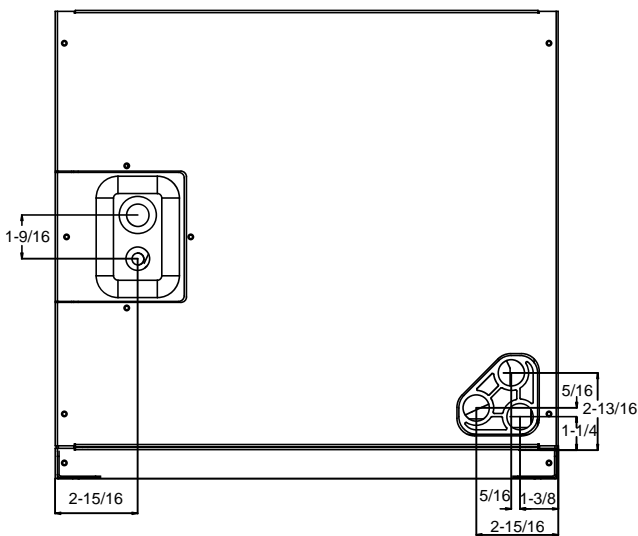

Fig.2 DIMENSIONS FOR FRONT CONNECT COIL

3.2 VERTICAL DOWNFLOW

Conversion to Vertical Downflow: A vertical upflow unit may be converted to vertical downflow. Remove the door and indoor coil and reinstall 180° from original position. See Fig 3.

IMPORTANT: To comply with certification agencies and the National Electric Code for downflow application, the circuit breaker(s) on field-installed electric heater kits must be re-installed per procedure below so that the breaker switch “on” position and marking is up and, “off” position and marking is down.

- To rotate breaker(s): Rotate one breaker set (circuit) at a time starting with the one on the right. Loosen both lugs on the load side of the breaker. (Make sure that wires are identified and are reinstalled into proper breaker). Wires are bundles with wire ties, one bundle going to the right lug and one bundle going to the left lug.

- Using a screwdriver or pencil, lift white plastic tab with hole away from breaker until breaker releases from mounting opening.
- With breaker held in hand, rotate breaker so that “on” position is up, “off” position is down with unit in planned vertical mounting position. Insert right wire bundle into top right breaker lug, ensuring all strands of all wires are inserted fully into lug, and no wire insulation is in lug.
- Tighten lug as tight as possible while holding circuit breaker. Check wires and make sure each wire is secure and none are loose. Repeat for left wire bundle in left top circuit breaker lug.
- Replace breaker by inserting breaker mounting tab opposite white pull tab in opening, hook mounting tab over edge in opening.
- With screwdriver or pencil, pull blue tab with hole away from breaker while setting that side of breaker into opening. When breaker is in place, release tab, locking circuit breaker into location in opening.
- Repeat above operation for remaining breaker(s) (if more than one is provided).
- Replace single point wiring jumper bar, if it is used, on line side of breaker and tighten securely.
- Double check wires and lugs to make sure all are secure and tight. Check to make sure unit wiring to circuit breaker load lugs match that shown on the unit wiring diagram.

	CAUTION
When using the unit with electrical heater, the switch is used only for electrical heater on the front of panel.	

3.3 HORIZONTAL

Horizontal right is the default factory configuration for the units.

Conversion to Horizontal left: A vertical upflow unit may be converted to horizontal left by removing indoor coil assembly and reinstalling coil as shown for left hand air supply.

- Rotate unit into the downflow position, with the coil compartment on top and the blower compartment on bottom. See Fig. 3
- Reinstall the indoor coil 180° from original position. Ensure the retaining channel is fully engaged with the coil rail. See Fig. 3.
- Secondary drain pan kits are recommended when the unit is configured for the horizontal position over a finished ceiling and/or living space.

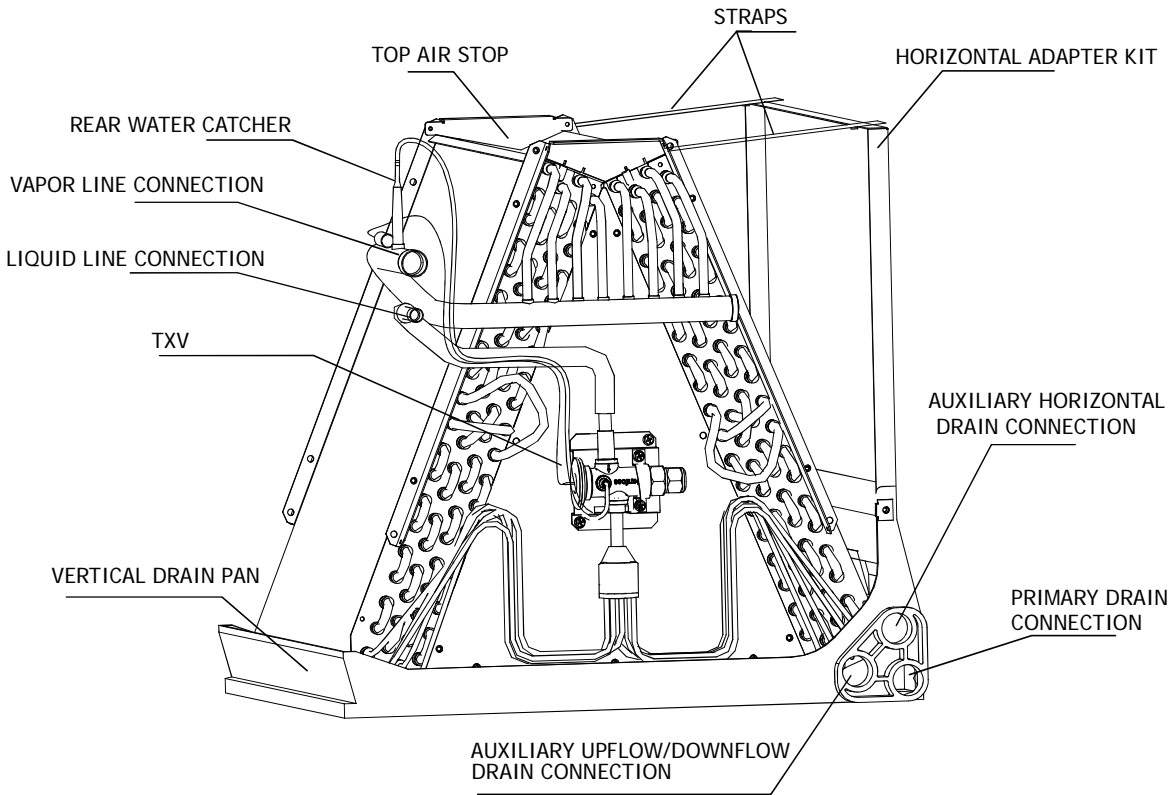
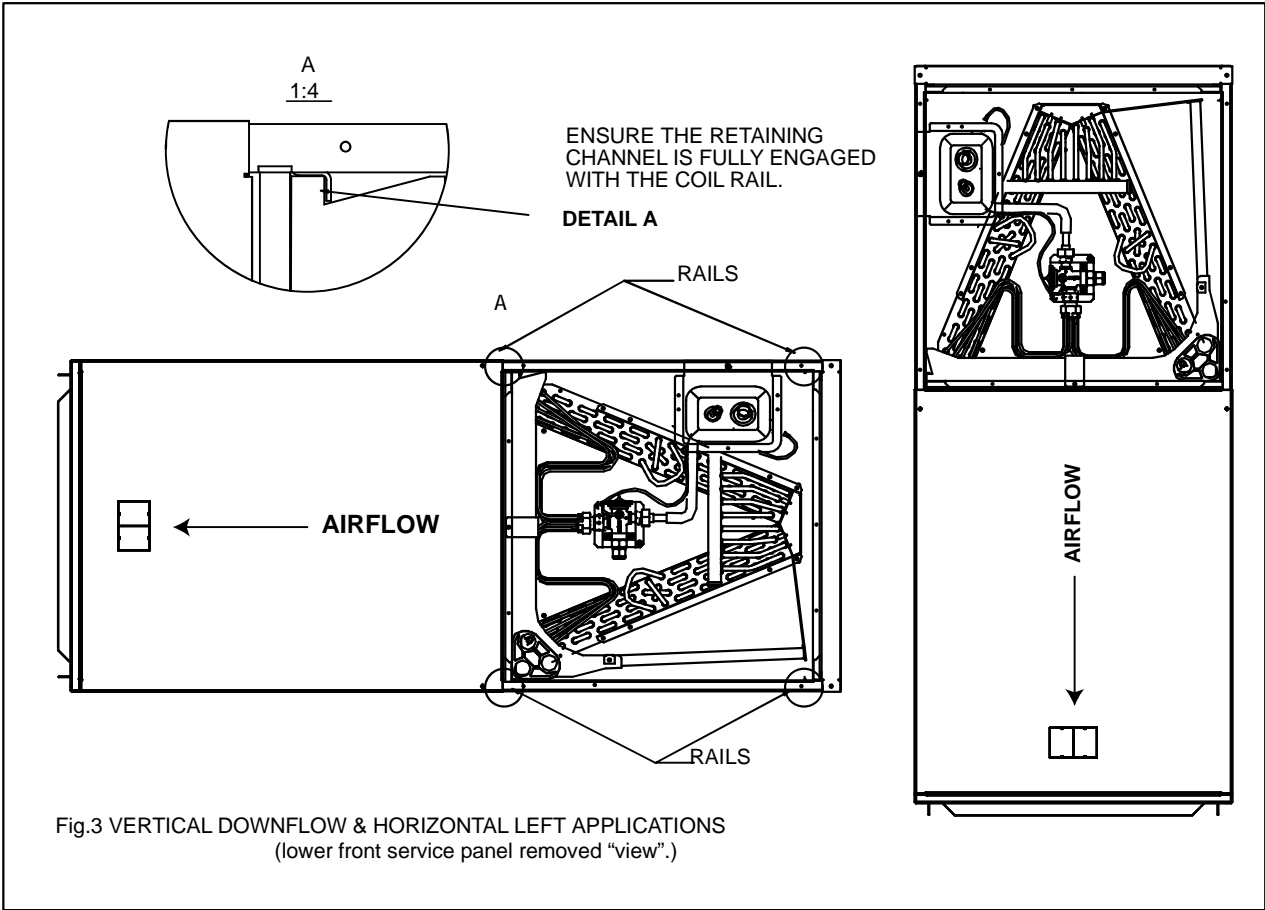



CAUTION

Horizontal units must be configured for right hand air supply or left hand air supply. Horizontal drain pan must be located under indoor coil. Failure to use the drain pan can result in property damage.

3.4 INSTALLATION IN AN UNCONDITIONED SPACE

IMPORTANT: There are two pairs of coil rails in the air handler for default and counter flow application. If the air handler is installed in an unconditioned space, the two unused coil rails should be removed to minimize air handler surface sweating. The coil rails can be easily removed by taking off the 6 mounting screws from both sides of the cabinet.

4. ELECTRICAL WIRING

Field wiring must comply with the National Electric Code (C.E.C. in Canada) and any applicable local ordinance.



WARNING

Disconnect all power to unit before installing or servicing. More than one disconnect switch may be required to de-energize the equipment. Hazardous voltage can cause severe personal injury or death.

4.1 POWER WIRING

It is important that proper electrical power is available for connection to the unit model being installed. See the unit nameplate, wiring diagram and electrical data in the installation instructions.

- If required, install a branch circuit disconnect of adequate size, located within sight of, and readily accessible to the unit.
- **IMPORTANT:** After the Electric Heater is installed, units may be equipped with one or two 30-60 amp. circuit breakers. These breaker(s) protect the internal wiring in the event of a short circuit and serve as a disconnect. Circuit breakers installed within the unit do not provide over-current protection of the supply wiring and therefore may be sized larger than the branch circuit protection.
- Supply circuit power wiring must be 75°C minimum copper conductors only. See Electrical Data In this section for ampacity, wire size and circuit protector requirement. Supply circuit protective devices may be either fuses or "HACR" type circuit breakers.

- Power wiring may be connected to either the right, left side or top. Three 7/8", 1-3/8", 1-3/4" dia. concentric knockouts are provided for connection of power wiring to unit.
- Power wiring is connected to the power terminal block in unit electric cabinet.

4.2 CONTROL WIRING

IMPORTANT: Class 2 low voltage control wiring should not be run in conduit with main power wiring and must be separated from power wiring, unless class 1 wire of proper voltage rating is used.

- Low voltage control wiring should be 18 Awg. color-coded. For lengths longer than 100 ft., 16 Awg. wire should be used.
- Low voltage control connections are made to low voltage pigtailed within air handler control box.

See wiring diagrams attached to indoor and outdoor sections to

- be connected.

Make sure, after installation, separation of control wiring and

- power wiring has been maintained.

4.3 GROUNDING



WARNING

The unit must be permanently grounded. Failure to do so can result in electrical shock causing personal injury or death.

- Grounding may be accomplished by grounding metal conduit when installed in accordance with electrical codes to the unit cabinet.
- Grounding may also be accomplished by attaching ground wire(s) to ground lug(s) provided in the unit wiring compartment.
- Use of multiple supply circuits require grounding of each circuit to lug(s) provided in unit.

4.4 ELECTRICAL DATA

MODEL	VOLTAGE	HERTZ	HP	SPEEDS	CIRCUIT AMPS.	MAXIMUM CIRCUIT PROTECTOR
24	208/230	60	1/3	5	3.5	15(A)
36	208/230	60	1/2	5	5.1	15(A)
48	208/230	60	3/4	5	7.5	15(A)
60	208/230	60	3/4	5	7.5	15(A)

4.5 ELECTRIC KIT MCA/MOP DATA

Heat Kit Model	Air Handler Model	(kW)Electric Heat	MIN. Circuit Ampacity		MAX.Fuse or Breaker (HACR) Ampacity		Fan speed				
			230	208	230	208	1	2	3	4	5
EHK05A	24	5	27.2	24.6	30	25	●	●	●	●	●
EHK08A		7.5	40.8	36.9	45	40	X	X	●	●	●
EHK10A		10	54.4	49.2	60	50	X	X	●	●	●
EHK05A	36	5	27.2	24.6	30	25	●	●	●	●	●
EHK08A		7.5	40.8	36.9	45	40	X	●	●	●	●
EHK10A		10	54.4	49.2	60	50	X	X	●	●	●
EHK15B		15	81	74	90	80	X	X	●	●	●
EHK05A	48	5	27.2	24.6	30	25	●	●	●	●	●
EHK08A		7.5	40.8	36.9	45	40	●	●	●	●	●
EHK10A		10	54.4	49.2	60	50	X	●	●	●	●
EHK15B		15	81	74	90	80	X	X	●	●	●
EHK20B		20	108	98	110	100	X	X	X	●	●
EHK05A	60	5	27.2	24.6	30	25	X	X	●	●	●
EHK08A		7.5	40.8	36.9	45	40	X	X	●	●	●
EHK10A		10	54.4	49.2	60	50	X	X	●	●	●
EHK15B		15	81	74	90	80	X	X	●	●	●
EHK20B		20	108	98	110	100	X	X	X	●	●

* Heat kit suitable for AHU 4-way position installation[● means available. X means not available].

Electric Heater Kits

NO.	Kit#	Description	Ref. Air Handler use
1	EHK05A	5kW Heat Strip,Double Pole Breaker	24,36,48,60
2	EHK08A	7.5kW Heat Strip,Double Pole Breaker	24,36,48,60
3	EHK10A	10kW Heat Strip,Double Pole Breaker	24,36,48,60
4	EHK15B	15kW Heat Strip,Double Pole Breaker	36,48,60
5	EHK20B	20kW Heat Strip,Double Pole Breaker	48,60

5. AIRFLOW PERFORMANCE

Airflow performance data is based on cooling performance with a dry coil and no filter in place. Select performance table for appropriate unit size external static applied to unit allows operation within the minimum and maximum limits shown in table below for both cooling and electric heat operation.

Model Number	Motor Speed		SCFM(Watts)										
			External Static Pressure-Inches W.C.[kPa]										
			0[0]	0.1[.02]	0.16[.04]	0.2[.05]	0.3[.07]	0.4[.10]	0.5[.12]	0.6[.15]	0.7[.17]	0.8[.20]	
24	Tap(5)	SCFM	1016	955	924	914	870	827	790	741	691	657	
		Watts	139	146	156	157	165	174	185	195	202	209	
	Tap(4)	SCFM	955	892	863	853	804	768	729	671	630	---	
		Watts	118	125	134	135	142	152	162	169	178	---	
	Tap(3) -Factory	SCFM	927	829	791	789	739	701	643	597	---	---	
		Watts	109	105	112	113	121	131	137	147	---	---	
	Tap(2)	SCFM	887	766	683	671	631	567	522	465	---	---	
		Watts	97	87	82	83	93	99	108	112	---	---	
	Tap(1)	SCFM	829	698	589	547	366	347	277	234	---	---	
		Watts	81	71	63	60	54	60	64	72	---	---	
	36	Tap(5)	SCFM	1532	1471	1428	1386	1372	1327	1271	1210	1159	1101
			Watts	233	247	262	266	270	275	281	290	298	310
Tap(4)		SCFM	1408	1343	1297	1265	1246	1197	1141	1073	1015	880	
		Watts	197	209	214	219	222	227	238	245	256	273	
Tap(3) -Factory		SCFM	1326	1230	1174	1151	1107	1024	896	828	807	726	
		Watts	148	165	172	175	183	190	202	217	221	225	
Tap(2)		SCFM	1236	1175	1100	1075	1029	963	835	736	661	582	
		Watts	124	130	133	137	142	146	157	168	176	187	
Tap(1)		SCFM	1182	1141	1020	995	944	818	648	553	461	363	
		Watts	124	112	105	103	107	112	124	129	140	149	
48		Tap(5)	SCFM	2072	2013	1970	1935	1923	1878	1830	1783	1736	1688
			Watts	447	464	483	489	497	514	530	545	558	570
	Tap(4)	SCFM	1860	1816	1783	1735	1679	1640	1591	1542	1504	1481	
		Watts	348	364	378	383	395	408	418	429	451	463	
	Tap(3) -Factory	SCFM	1702	1651	1598	1560	1547	1497	1438	1385	1331	1280	
		Watts	268	281	296	304	312	325	337	349	361	375	
	Tap(2)	SCFM	1393	1358	1197	1179	1155	1139	1074	1020	964	896	
		Watts	227	234	248	258	269	270	283	296	313	325	
	Tap(1)	SCFM	1365	1239	1148	1078	1050	965	904	886	831	797	
		Watts	220	226	231	243	264	269	281	293	301	317	
	60	Tap(5)	SCFM	2054	2015	1970	1947	1928	1886	1846	1804	1742	1654
			Watts	470	495	512	518	528	542	553	569	567	548
Tap(4) -Factory		SCFM	1883	1840	1797	1783	1754	1712	1670	1622	1579	1541	
		Watts	367	388	406	411	420	422	445	454	466	479	
Tap(3)		SCFM	1721	1674	1625	1582	1566	1528	1484	1443	1401	1345	
		Watts	289	305	319	327	330	341	353	365	378	387	
Tap(2)		SCFM	1515	1463	1407	1386	1358	1308	1262	1215	1153	1073	
		Watts	205	218	229	235	239	251	263	276	285	301	
Tap(1)		SCFM	1337	1265	1208	1156	1148	1095	984	955	963	789	
		Watts	145	157	167	173	178	186	197	212	225	235	

--- Shaded boxes represent airflow outside the required 300-450 cfm/ton.

NOTES: Airflow based upon cooling performance at 230V with no electric heat and no filter. Airflow at 208V is approximately the same as 230V because the multi-tap ECM motor is a constant torque motor. The torque doesn't drop off at the speeds in which the motor operates.

The air distribution system has the greatest effect on airflow. The duct system is totally controlled by the contractor. For this reason, the contractor should use only industry-recognized procedures.

Heat pump systems require a specified airflow. Each ton of cooling requires between 350 and 450 cubic feet of air per minute (CFM), or 400 CFM nominally.

Duct design and construction should be carefully done. System performance can be lowered dramatically through bad planning or workmanship.

Air supply diffusers must be selected and located carefully. They must be sized and positioned to deliver treated air along the perimeter of the space. If they are too small for their intended airflow, they become noisy. If they are not located properly, they cause drafts. Return air grilles must be properly sized to carry air back to the blower. If they are too small, they also cause noise.

The installers should balance the air distribution system to ensure proper quiet airflow to all rooms in the home. This ensures a comfortable living space.

An air velocity meter or airflow hood can be used to balance and verify branch and system airflow (CFM).

6. DUCTWORK

Field ductwork must comply with the National Fire Protection Association NFPA 90A, NFPA 90B and any applicable local ordinance.



WARNING

Do not, under any circumstances, connect return ductwork to any other heat producing device such as fireplace insert, stove, etc. Unauthorized use of such devices may result in fire, carbon monoxide poisoning, explosion, personal injury or property damage.

Sheet metal ductwork run in unconditioned spaces must be insulated and covered with a vapor barrier. Fibrous ductwork may be used if constructed and installed in accordance with SMACNA Construction Standard on Fibrous Glass Ducts. Ductwork must comply with National Fire Protection Association as tested by U/L Standard 181 for Class I Air Ducts. Check local codes for requirements on ductwork and insulation.

- Duct system must be designed within the range of external static pressure the unit is designed to operate against. It is important that the system airflow be adequate. Make sure supply and return ductwork, grills, special filters, accessories, etc. are accounted for in total resistance. See airflow performance tables in this manual.

- Design the duct system in accordance with “ACCA” Manual “D” Design for Residential Winter and Summer Air Conditioning and Equipment Selection. Latest editions are available from: “ACCA” Air Conditioning Contractors of America, 1513 16th Street, N.W., Washington, D.C. 20036. If duct system incorporates flexible air duct, be sure pressure drop Information (straight length plus all turns) shown in “ACCA” Manual “D” is accounted for in system.
- Supply plenum is attached to the 3/4” duct flanges supplied with the unit. Attach flanges around the blower outlet.
IMPORTANT: If an elbow is included in the plenum close to the unit, it must not be smaller than the dimensions of the supply duct flange on the unit.
- IMPORTANT: The front flange on the return duct if connected to the blower casing must not be screwed into the area where the power wiring is located. Drills or sharp screw points can damage insulation on wires located inside unit.
- Secure the supply and return ductwork to the unit flanges, using proper fasteners for the type of duct used and tape the duct-to-unit joint as required to prevent air leaks.

7. REFRIGERANT CONNECTIONS

Keep the coil connections sealed until refrigerant connections are made. See the Installation Instructions for the outdoor unit for details on line sizing, tubing installation, and charging information.

Coil is shipped with “N2”. Evacuate the system before charging with refrigerant.

Install refrigerant tubing so that it does not block service access to the front of the unit.

Nitrogen should flow through the refrigerant lines while brazing.

Use a wet rag or an approved heat paste to protect the TXV sensing bulb during the braze process.

After the refrigerant connections are made, seal the gap around the connections with pressure sensitive gasket.

7.1 CONDENSATE DRAIN TUBING

Consult local codes for specific requirements.

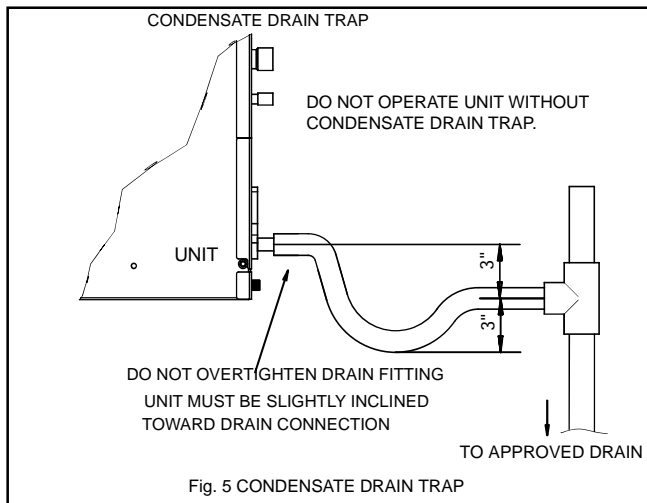

IMPORTANT:

1. When making drain fitting connections to the drain pan, use a thin layer of Teflon paste, silicone or Teflon tape and install, hand tighten.
2. When making drain fitting connections to drain pan, do not overtighten. Over tightening fittings can split pipe connections on the drain pan.

- Install drain lines so they do not block service access to front of the unit. Minimum clearance of 24 inches is required for filter, coil or blower removal and service access.
- Make sure unit is level or pitched slightly toward primary drain connection so that water will drain completely from the pan. (See Fig. 5)
- Do not reduce drain line size less than connection size provided on condensate drain pan.
- All drain lines must be pitched downward away from the unit a minimum of 1/8" per foot of line to ensure proper drainage.
- Do not connect condensate drain line to a closed or open sewer pipe. Run condensate to an open drain or run line to a safe outdoor area.
- The drain line should be insulated where necessary to prevent sweating and damage due to condensate forming on the outside surface of the line.
- Make provisions for disconnecting and cleaning of the primary drain line should it become necessary. Install a 3 inch trap in the primary drain line as close to the unit as possible. Make sure that the top of the trap is below connection to the drain pan to allow complete drainage of pan (See Fig. 5).
- Auxiliary drain line should be run to a place where it will be noticeable if it becomes operational. Homeowner should be warned that a problem exists if water should begin running from the auxiliary drain line.

- Plug the unused drain connection with the plugs provided in the parts bag, using a thin layer of teflon paste, silicone or teflon tape to form a water tight seal.
- Test condensate drain pan and drain line after installation is complete. Pour water into drain pan, enough to fill drain trap and line. Check to make sure drain pan is draining completely, no leaks are found in drain line fittings, and water is draining from the termination of the primary drain line.

8. AIR FILTER (not factory-installed)

External filter or other means of filtration is required. Units should be sized for a maximum of 300 feet/min. air velocity or what is recommended for the type filter installed.

Filter application and placement are critical to airflow, which may affect the heating and cooling system performance. Reduced airflow can shorten the life of the system's major components, such as motor, limits, elements, heat relays, evaporator coil or compressor. Consequently, we recommend that the return air duct system have only one filter location. For systems with a return air filter grill or multiple filter grills, can have a filter installed at each of the return air openings.

If adding high efficiency filters or electronic air filtration systems, it is very important that the air flow is not reduced. If air flow is reduced the overall performance and efficiency of the unit will be reduced. It is strongly recommended that a professional installation technician is contacted to ensure installation of these such filtration systems are installed correctly.

IMPORTANT: DO NOT DOUBLE FILTER THE RETURN AIR DUCT SYSTEM. DO NOT FILTER THE SUPPLY AIR DUCT SYSTEM. THIS WILL CHANGE THE PERFORMANCE OF THE UNIT AND REDUCE AIRFLOW .

	WARNING
<p>Do not operate the system without filters. A portion of the dust entrained in the air may temporarily lodge in the duct runs and at the supply registers. Any circulated dust particles could be heated and charred by contact with the air handler elements. This residue could soil ceilings, walls, drapes, carpets and other articles in the house.</p> <p>Soot damage may occur with filters in place, when certain types of candles, oil lamps or standing pilots are burned.</p>	

9. FILTER INSTALLATION DIMENSIONS

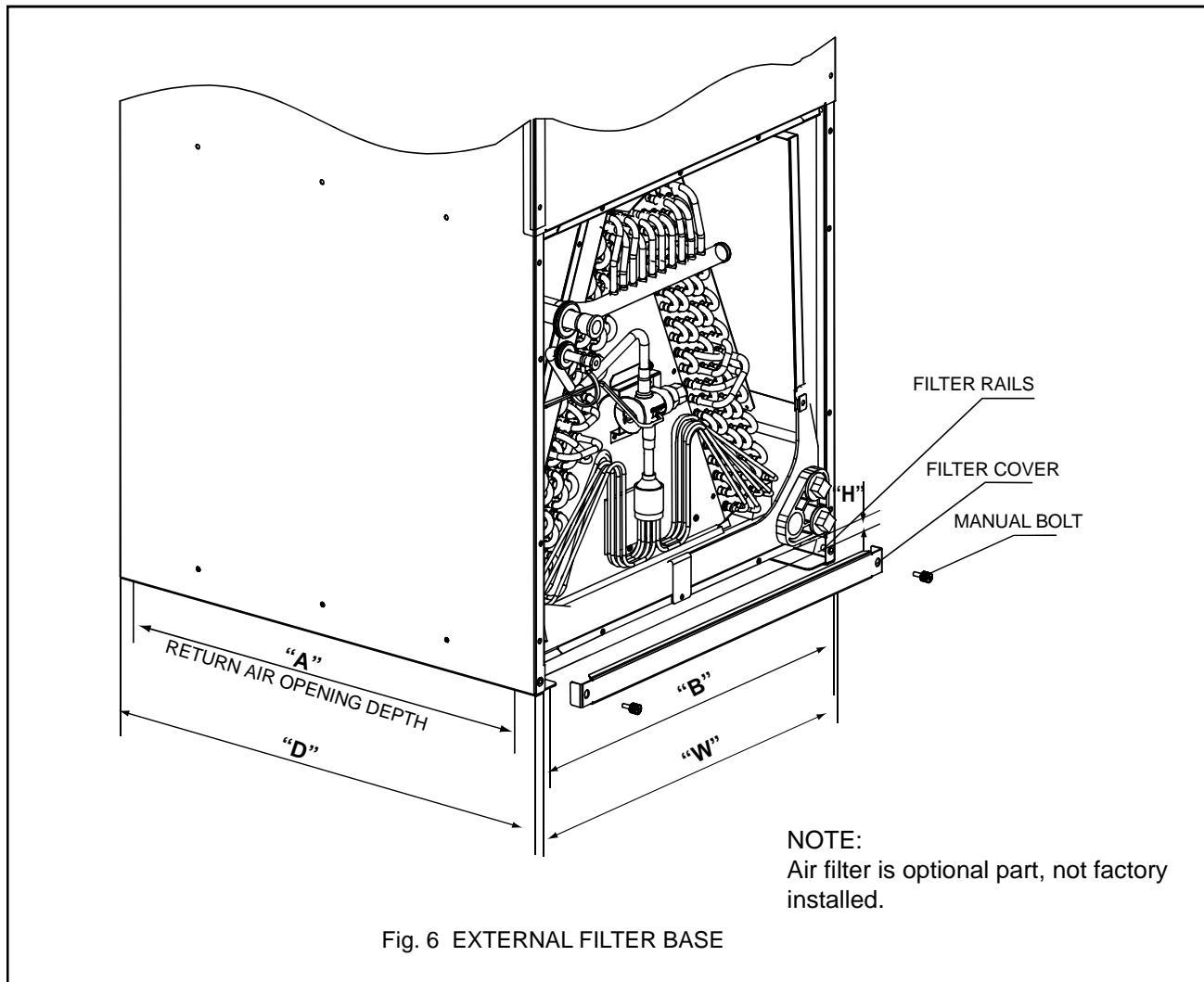

DIMENSIONAL DATA

MODEL	FILTER SIZE IN [mm]	"W" IN [mm]	"D" IN [mm]	"H" IN [mm]	Return width "A" IN	Return length "B" IN
24	18X20[457X508]	18.3[466]	21.6[548]	1[25.4]	20.8	16.3
36/48/60	20X22[508X559]	20.7[526]	23.9[608]	1[25.4]	23	18.8

• AIR FILTER REMOVAL / INSTALLATION

1. Remove bolts manually, remove air filter recover, see in Fig. 6;
2. Hold the edge of the air filter and extract out .
3. Install new filter so that the arrow on the filter is in the same direction as airflow.

10. WIRING DIAGRAM

1. To avoid the electrical shock, please connect the air conditioner with the ground lug. The main power plug in the air conditioner has been joined with the ground wiring, please don't change it freely.
2. The power socket is used as the air conditioner specially.
3. Don't pull the power wiring hard.

4. When connecting the air conditioner with the ground, observe the local codes.
5. If necessary, use the power fuse or the circuit, breaker or the corresponding scale ampere.

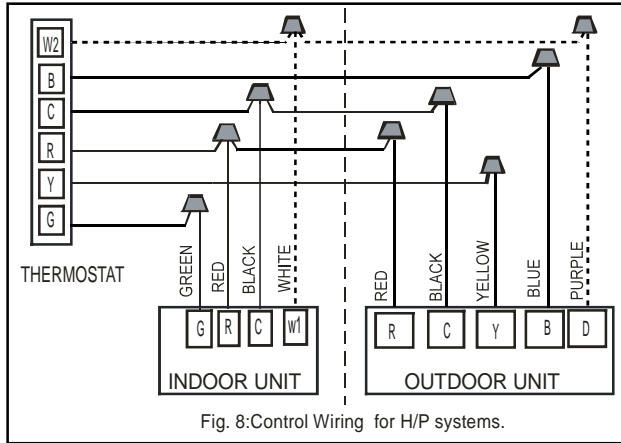

Fig. 8:Control Wiring for H/P systems.

Note: Broken lines means H/P system with electric heating. Wiring please refer to the Owner's Manual of the thermostat.

ELECTRIC WIRING GAUGE for H/P systems

Model(Btu/h)		24	36	48	60	
Power	Phase	Single				
	Voltage/frequency	208/230V, 60Hz				
Lines Gauge	Input Current Fuse	Indoor unit (A)				
	Indoor Unit Power Line	Line Quantity	15A	15A	15A	15A
		Line Diameter(AWG)	3	3	3	3
	Outdoor Unit Power Line	Line Quantity	14	14	14	14
		Line Diameter(AWG)	3	3	3	3
	Outdoor -Indoor Signal Line	Line Quantity	14	12	10	10
		Line Diameter(AWG)	4	4	4	4
	Thermostat Signal Line	Line Quantity	4	4	4	4
Line Diameter(AWG)		18	18	18	18	
Thermostat Signal Line	Line Quantity	5	5	5	5	
	Line Diameter(AWG)	18	18	18	18	

NOTE: If indoor unit has auxiliary heating already installed and a different auxiliary heating unit is required the indoor unit (A) and indoor line diameters will be different.

These units must be wired and installed in accordance with all National and Local Safety Codes.

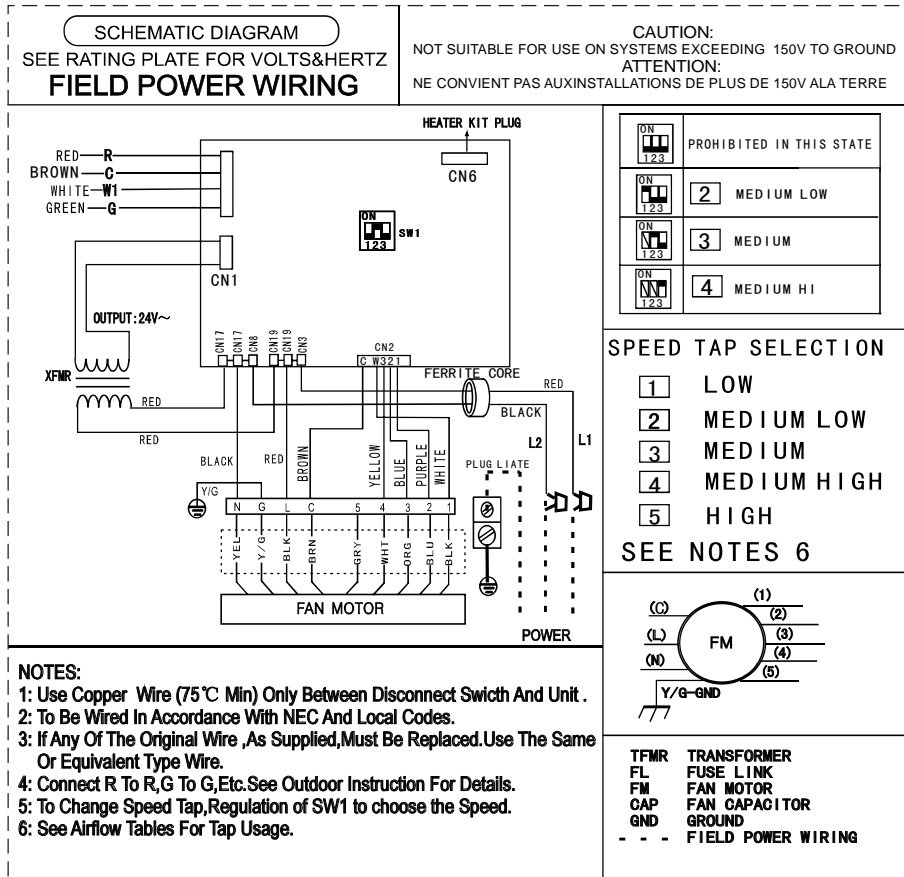

Fig.9: Indoor Unit Wiring Diagram for ECM Motor (24/36/48K).

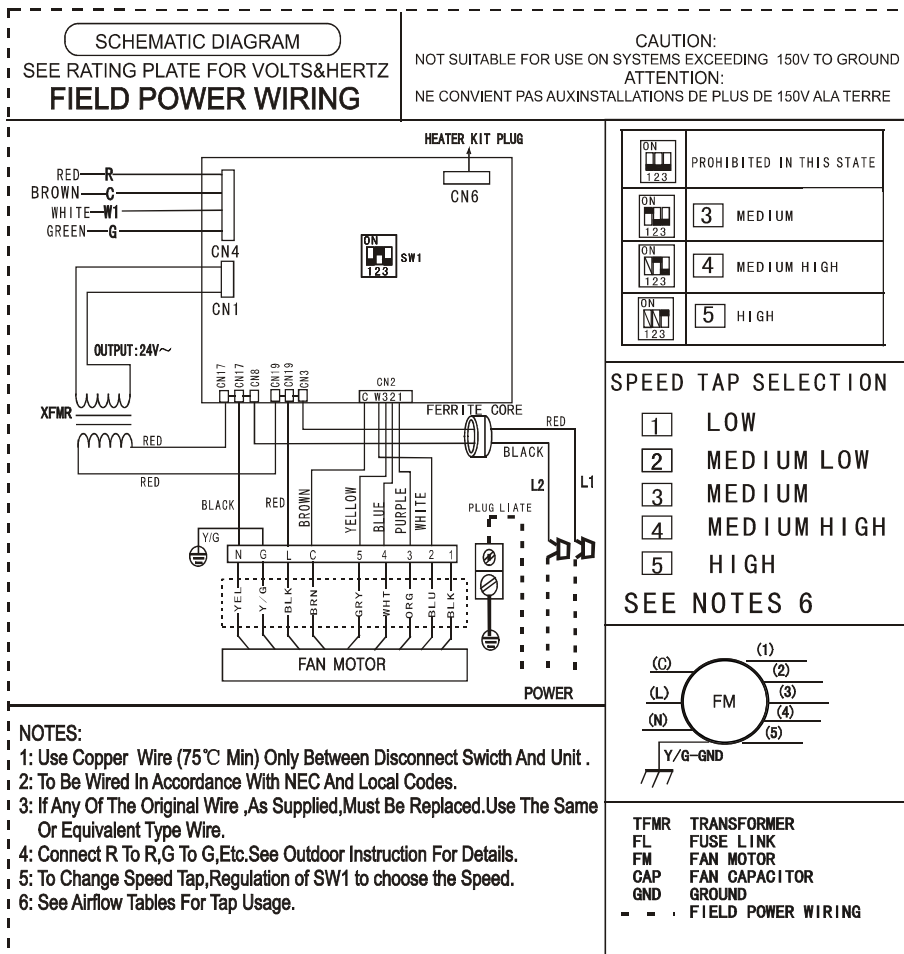

Fig.10: Indoor Unit Wiring Diagram for ECM Motor (60K).

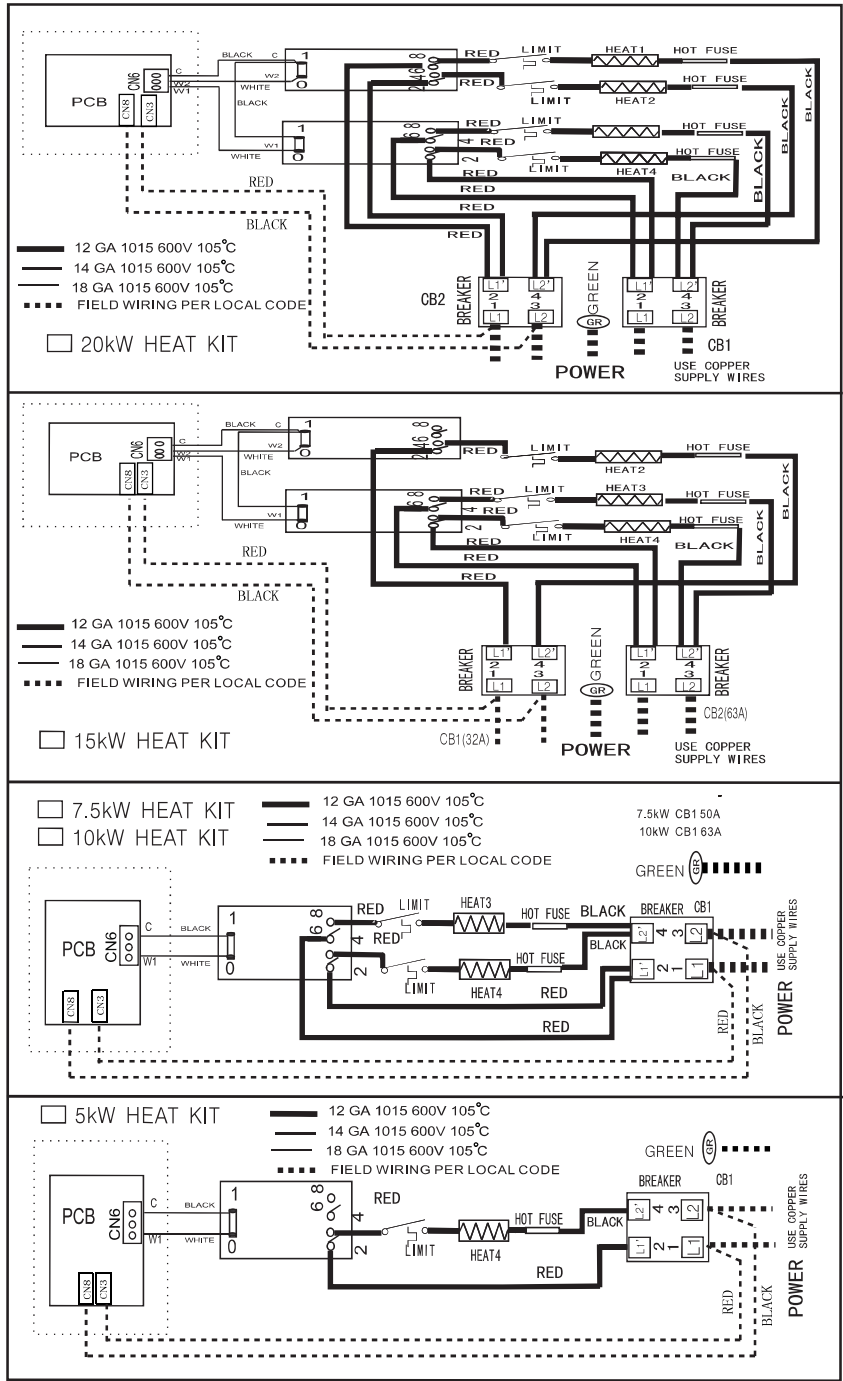

Fig.11: Indoor Unit Wiring Diagram for Electric Heat.

Wiring is subject to change. Always refer to the wiring diagram on the unit for the most up-to-date wiring.

WARNING

High Voltage: Disconnect all power before servicing or installing this unit. Multiple power sources may be present. Failure to do so may cause property damage, personal injury, or death.



WARNING

HIGH VOLTAGE!
DISCONNECT ALL POWER BEFORE SERVICING OR INSTALLING THIS UNIT. MULTIPLE POWER SOURCES MAY BE PRESENT. FAILURE TO DO SO MAY CAUSE PROPERTY DAMAGE, PERSONAL INJURY OR DEATH.



NOTES:

NOTES:

NOTES:

United States and Canada

**Bosch Thermotechnology Corp.
50 Wentworth Avenue
Londonderry, NH 03053**

Tel: 866-305-9974