

Bosch 80% AFUE Gas Furnace BGS80 Model

4-Way Multipoise Category I Fan-Assisted Furnace



BOSCH

Installation, Operation, and Maintenance Manual



Table of Contents

1 Key to Symbols and Safety Instructions	4	10 Electrical Connections	27
1.2 Safety	4	10.1 115V Wiring	27
2 Dimensions	7	10.2 Electrical Connection to J-box	28
3 Introduction	8	10.3 Power Cord Installation in Furnace J-box	28
4 Codes and Standards	9	10.4 BX Cable Installation in Furnace J-box	28
4.1 Safety	9	10.5 24-V Wiring	28
4.2 General Installation	9	10.6 Accessories (Field Supplied)	28
4.3 Combustion and Ventilation Air	9	10.7 Grounding	28
4.4 Duct Systems	9	11 Start-Up, Adjustment, and Safety Check	31
4.5 Acoustical Lining and Fibrous Glass Duct	9	11.1 General	31
4.6 Gas Piping and Gas Pipe Pressure Testing	9	11.2 Start-Up Procedures	31
4.7 Electrical Connections	9	11.3 Furnace Start-Up	31
4.8 Electrical Power Supply	9	11.4 Sequence of Operation	32
4.9 Venting	9	11.5 Gas Manifold Pressure Measurement and Adjustment	33
5 Electrostatic Discharge (ESD) Precautions Procedure	10	11.6 Gas Input Rate Measurement (Natural Gas Only)	34
6 Location	10	11.7 Temperature Rise Adjustment	34
6.1 General	10	11.8 Circulator Blower Speed Adjustment	34
7 Installation	12	12 Operational Checks	35
7.1 Upflow Installation	12	13 Safety Circuit Description	35
7.2 Downflow Installation	12	13.1 General	35
7.3 Horizontal Installation	14	13.2 Integrated Control Module	35
7.4 Furnace Installation Orientations	15	13.3 Chamber Limit Switch - Fixed	35
7.5 Filter Arrangement	17	13.4 Fan Mounted Limit Switch	35
7.6 Air Ducts	18	13.5 Rollout Switch - Resettable	35
8 Vent System	20	13.6 Pressure Switches	35
8.1 Vent Connections	20	13.7 Flame Sensor	35
8.2 Venting	20	14 Troubleshooting	36
8.3 Venting Into a Masonry Chimney	20	14.1 Electrostatic Discharge (ESD) Precautions	36
8.4 Air for Combustion and Ventilation	20	14.2 Troubleshooting Chart	36
8.5 Air Supply Openings and Ducts	22	14.3 Resetting From Lockout	36
8.6 Ventilated Combustion Air	22	15 Service and Maintenance Procedures	40
8.7 Vent and Supply (Outside) Air Safety Check Procedure	22	15.1 Annual Inspection	40
9 Gas Supply and Piping	23	15.2 Filters	40
9.1 General	23	15.3 Induced Draft And Circulating Blower Motors	40
9.2 High Altitude Derate	24	15.4 Flame Sensor (Qualified Service Technicians Only)	40
9.3 Propane Gas (LP) Conversion	24	15.5 Burners	41
9.4 Gas Piping Connections	25	15.6 Inspecting the Heat Exchanger	41
9.5 Gas Piping Checks	26	15.7 Repair and Replacement Parts	41
		16 Before Leaving Installation	41
		17 Wiring Diagrams	43

1 Key to Symbols and Safety Instructions

1.1 Key to Symbols

Warnings



Warnings in this document are identified by a warning triangle printed against a grey background. Keywords at the start of a warning indicate the type and seriousness of the ensuing risk if measures to prevent the risk are not taken.

The following keywords are defined and can be used in this document:

- ▶ **DANGER** indicates a hazardous situation which, if not avoided, will result in death or serious injury.
- ▶ **WARNING** indicates a hazardous situation which, if not avoided, could result in death or serious injury.
- ▶ **CAUTION** indicates a hazardous situation which, if not avoided, could result in minor to moderate injury.
- ▶ **NOTICE** is used to address practices not related to personal injury.

Important information



This symbol indicates important information where there is no risk to people or property.

1.2 Safety

Please read all instruction in the manual and retain all manuals for future reference.



INSTALLER: Use the information in this booklet to install the appliance and affix this booklet adjacent to the appliance after installation.

USER: Keep this booklet of information for future reference. Refer to the User's Information Manual for more information.

SERVICER: Use the information in this booklet to service the appliance and affix the booklet adjacent to the appliance after servicing.



WARNING: FIRE OR EXPLOSION HAZARD

- ▶ Do not store or use gasoline or other flammable vapors and liquids in the vicinity of this or any other appliance.
- ▶ **WHAT TO DO IF YOU SMELL GAS:**
 - Do not try to light any appliance.
 - Do not touch any electrical switch; do not use any phone in your building.
 - Leave the building immediately.
 - Immediately call your gas supplier from a neighbor's phone. Follow the gas supplier's instructions.
 - If you cannot reach your gas supplier, call the fire department.
- ▶ Installation and service must be performed by a qualified installer, service agency, or the gas supplier.



Do not use this furnace if any part has been under water. A flood-damaged furnace is extremely dangerous. Attempts to use the furnace can result in fire or explosion. A qualified service agency should be contacted to inspect the furnace and to replace all gas controls, control system parts, and electrical parts that have been wet, or the furnace if deemed necessary.



WARNING: FIRE OR EXPLOSION HAZARD

- ▶ The furnace is designed and approved for use with Natural Gas and (LP) Propane Gas ONLY.
- ▶ **DO NOT BURN ANY LIQUID FUEL OR SOLID FUEL IN THIS FURNACE.**
- ▶ Burning any unapproved fuel will result in damage to the furnace's heat exchanger, which could result in Fire, Personal Injury, and/or Property Damage.



WARNING:

- ▶ This product can expose you to chemicals including Lead and Lead components, which are known to the State of California to cause cancer and birth defects or other reproductive harm. For more information go to www.P65Warnings.ca.gov.

**WARNING: FOLLOW ALL SAFETY CODES**

- ▶ Wear safety glasses, protective clothing, and work gloves. Have a fire extinguisher available. Read these instructions thoroughly and follow all warnings or cautions included in literature and attached to the unit. Consult local building codes as well as the current editions of the National Fuel Gas Code (NFPA 54/ANSI Z223.1 and the National Electrical Code (NEC) NFPA 70.

**WARNING: FIRE, EXPLOSION, ELECTRICAL SHOCK, AND CARBON MONOXIDE POISONING HAZARD**

- ▶ Failure to follow this warning could result in dangerous operation, serious injury, death, or property damage. Improper installation, adjustment, alteration, maintenance, or use could cause carbon monoxide poisoning, explosion, fire, electrical shock, or other conditions which may cause personal injury or property damage. Consult a qualified service agency, local gas supplier, or your distributor for information or assistance.

**CAUTION: INSTALLATION REQUIREMENTS**

- ▶ Use only with type of gas approved for this furnace. Refer to the furnace rating plate.
- ▶ Install this furnace only in a location and position as specified in Section 6 "Location" of these instructions.
- ▶ Provide adequate combustion and ventilation air to the furnace space as specified in Section 8.4 "Air for Combustion and Ventilation".
- ▶ Combustion products must be discharged outdoors. Connect this furnace to an approved vent system only, as specified in Section 8.2 "Venting" of this manual.
- ▶ When a furnace is installed so that supply ducts carry air circulated by the furnace to areas outside the space containing the furnace, the return air shall also be handled by duct(s) sealed to the furnace casing and terminating outside the space containing the furnace. See Section 7.5 "Air Ducts".
- ▶ A gas-fired furnace for installation in a residential garage must be installed as specified in the warning box in Section 6 "Location".
- ▶ The furnace may be used for construction heat provided that the furnace installation and operation complies with the first CAUTION in Section 6 "Location" of these instructions.

**WARNING:**

- ▶ Always install furnace to operate within the furnace's intended temperature-rise range with a duct system which has an external static pressure within the allowable range, as specified in Section 11 "Start-Up, Adjustments, and Safety Check" or the furnace rating plate.

**WARNING: FIRE HAZARD**

- ▶ The furnaces must be kept free and clear of insulating materials. Inspect surrounding area to ensure insulation material is at a safe distance when installing furnaces or adding insulation materials. Insulation materials may be combustible.
See Section 3, Fig. 2 for required clearances to combustible construction.
Maintain a 1 in. clearance from combustible materials to supply air ductwork for a distance of 36 in. horizontally from the furnace. See NFPA 90B or local code for further requirements.
- ▶ These furnaces SHALL NOT be installed directly on carpeting, tile, or any other combustible material other than wood flooring. In downflow installations, field supplied floor base MUST be used when installed on combustible materials and wood flooring. Special base is not required when this furnace is installed on industry standard Coil Assembly matching correct furnace width.

**CAUTION: FURNACE RELIABILITY HAZARD**

- ▶ Improper installation or misapplication of furnace may require excessive servicing or cause premature component failure. Application of this furnace should be indoors with special attention given to vent sizing and material, gas input rate, air temperature rise, unit leveling, and unit sizing.

**CAUTION: CUT HAZARD**

- ▶ Failure to follow this caution may result in personal injury. Sheet metal parts may have sharp edges or burrs. Use care and wear appropriate protective clothing, safety glasses and gloves when handling parts and servicing furnaces.

**WARNING: FIRE, EXPLOSION**

- ▶ Check entire gas assembly for leaks after lighting this appliance.
- ▶ Never test for gas leaks with an open flame. Use a commercially available soap solution made specifically for the detection of leaks to check all connections, as specified in Section 9 "Gas Supply and Piping" section.

**CAUTION:**

- Before heating season begins, examine the furnace to ensure that:
1. All flue gas carrying areas external to the furnace (i.e. chimney, vent connector) are clear and free of obstructions.
 2. The vent connector is in place, slopes upward and is physically sound without holes or excessive corrosion.
 3. The return-air duct connection(s) is physically sound, is sealed to the furnace casing, and terminates outside the space containing the furnace.
 4. The physical support of the furnace is sound without sagging, cracks, gaps, etc around the base so as to provide a seal between the support and the base.
 5. There are no obvious signs of deterioration of the furnace.
 6. The burner flames are positioned correctly by comparing with pictorial sketches of the main burner flame (see Section 12, Fig 30).

**WARNING: FIRE, EXPLOSION**

- See instructions for lighting/shutdown operation (as shown at the bottom of this page, as well as on a sticker directly on the inside of the furnace panel). Should the gas supply fail to shut off or if overheating occurs, shut off the gas valve to the furnace before shutting off the electrical supply.

**WARNING:**

- Furnace operation requires air for combustion and ventilation. Do not block or obstruct air openings on furnace or spacing around furnace required for supplying sufficient combustion air and ventilation.

Instructions for lighting/shutdown operation:**FOR YOUR SAFETY READ BEFORE OPERATING****WARNING**

If you do not follow these instructions exactly, a fire or explosion may result causing property damage, personal injury or loss of life.

- A.** This appliance does not have a pilot. It is equipped with an ignition device which automatically lights the burner. **Do not** try to light the burner by hand.
- B. BEFORE OPERATING** smell all around the appliance area for gas. Be sure to smell next to the floor because some gas is heavier than air and will settle on the floor.
- FOR YOUR SAFETY
"WHAT TO DO IF YOU SMELL GAS"**
- Do not try to light any appliance.
 - Do not touch any electrical switch; do not use any phone in your building.
 - Immediately call your gas supplier from a neighbors phone. Follow the gas suppliers Instructions.
 - If you cannot reach your gas supplier, call the fire department.
- C.** Use only your hand to push the gas control switch. Never use tools. If the switch will not move by hand, don't try to repair it; call a qualified service technician. Force or attempted repair may result in a fire or explosion.
- D.** Do not use this appliance if any part has been under water. Immediately call a qualified service technician to inspect the appliance and to replace any part of the control system and any gas control which has been under water.

OPERATING INSTRUCTIONS

1. **STOP!** Read the safety information above on this label.
2. Set the thermostat to lowest setting.
3. Turn off all electric power to the appliance.
4. This appliance is equipped with an ignition device which automatically lights the burner. Do not try to light the burner by hand.
5. Remove access panels.
6. Push gas control switch to "OFF".
7. Wait five (5) minutes to clear out any gas. Then smell for gas, including near the floor. If you smell gas, **STOP!** Follow "B" in the safety information above on this label. If you don't smell gas, go to the next step.
8. Push gas control switch to "ON".
9. Replace access panels.
10. Turn on all electric power to the appliance.
11. Set thermostat to desired setting.
12. If the appliance will not operate, follow the instructions "To Turn Off Gas To Appliance" and call your service technician or gas supplier.

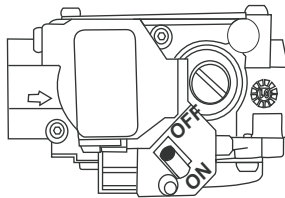

SWITCH SHOWN IN THE "OFF" POSITION

TO TURN OFF GAS TO APPLIANCE

1. Set the thermostat to lowest setting.
2. Turn off all electric power to the appliance if service is to be performed.
3. Remove access panels.
4. Push gas control switch to "OFF".
5. Replace access panels.

202082290022

2 Dimensions

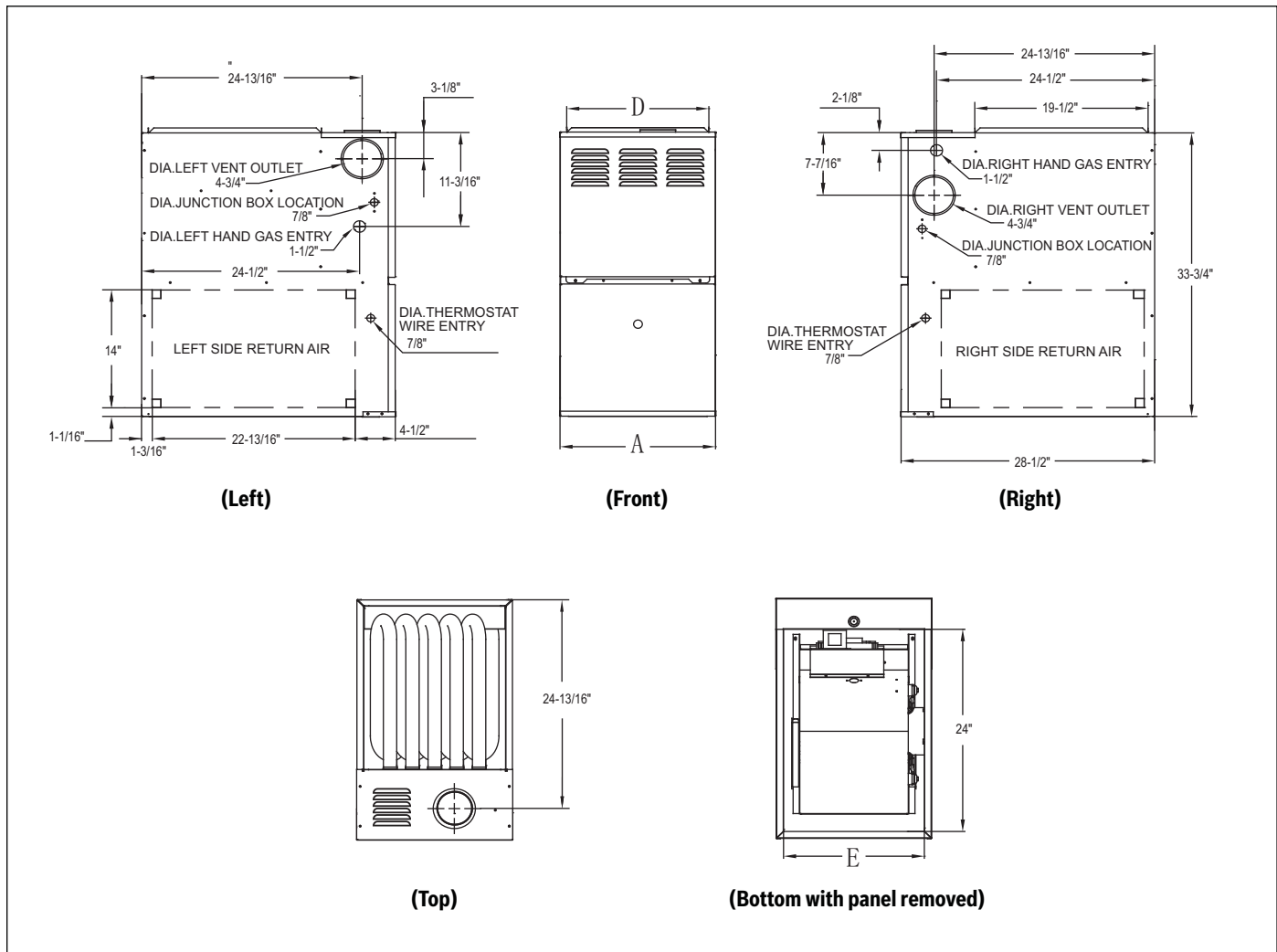

Figure 1 Dimensions

Furnace Model	"A" Cabinet Width	"D" Supply- Air Width	"E" Return- Air Width	Shipping Weight
BGS80M050A3A	14.5	13	12-27/32	137 lbs
BGS80M080B4A	17.5	16	15-27/32	158 lbs
BGS80M100C5A	21	19.5	19-13/32	178 lbs
BGS80M120D5A	24.5	23	22-27/32	180 lbs

Table 1 Dimensions - inch

3 Introduction

This 4-way Multipoise Category I Fan-assisted furnace is AHRI design-certified. A Category I Fan-assisted furnace is an appliance equipped with an integral mechanical means to either draw or force products of combustion through the combustion chamber and/or heat exchanger. This furnace is factory-shipped for use with natural gas.

This furnace is not approved for installation in mobile homes, recreational vehicles, or outdoors. This furnace is designed for minimum continuous return-air temperature of 60°F (16°C) (DBT) or intermittent operation down to 55°F (13°C) (DBT) such as when used with a night setback thermostat. Return-air temperature must not exceed 85°F (29°C) (DBT). Failure to follow these return-air temperature limits may affect reliability of heat exchangers, motors, and controls. (See Section 4.1, Fig. 3).

For accessory installation details, refer to the applicable instruction literature. A Natural Gas to LP conversion kit, supplied by the manufacturer with every furnace unit, shall be used to convert to propane gas (LP).

This furnace is for indoor installation in a building constructed on-site.

This furnace may be installed on combustible flooring in alcove or closet at minimum clearance as indicated by Figure 2.

This furnace may be used with a Type B-1 Vent and may be vented in common with other gas fired appliances.



Remove all shipping brackets and materials before operating the furnace.



WARNING: FIRE, EXPLOSION, ASPHYXIATION HAZARD

- ▶ Improper adjustment, alteration, service, maintenance, or installation can cause serious injury or death.

Read and follow instructions and precautions in User's Information Manual provided with this furnace. Installation and service must be performed by a qualified service agency or the gas supplier.



CAUTION:

▶ **INSTALLATION**

1. This furnace must be installed in accordance with the manufacturer's instructions and local codes. In the absence of local codes, follow the National Fuel Gas Code ANSI Z223.1/ NFPA54.
2. This furnace must be installed so there are provisions for combustion and ventilation air. See manufacturer's installation information provided with this appliance.

▶ **OPERATION**

This furnace is equipped with manual reset limit switch(es) in burner compartment to protect against overheat conditions that can result from inadequate combustion air supply or blocked vent conditions.

1. Do not bypass limit switches.
2. If a limit opens, call a qualified service technician to correct the condition and reset the limit switch.

This furnace is approved for UPFLOW, DOWNFLOW and HORIZONTAL installations.

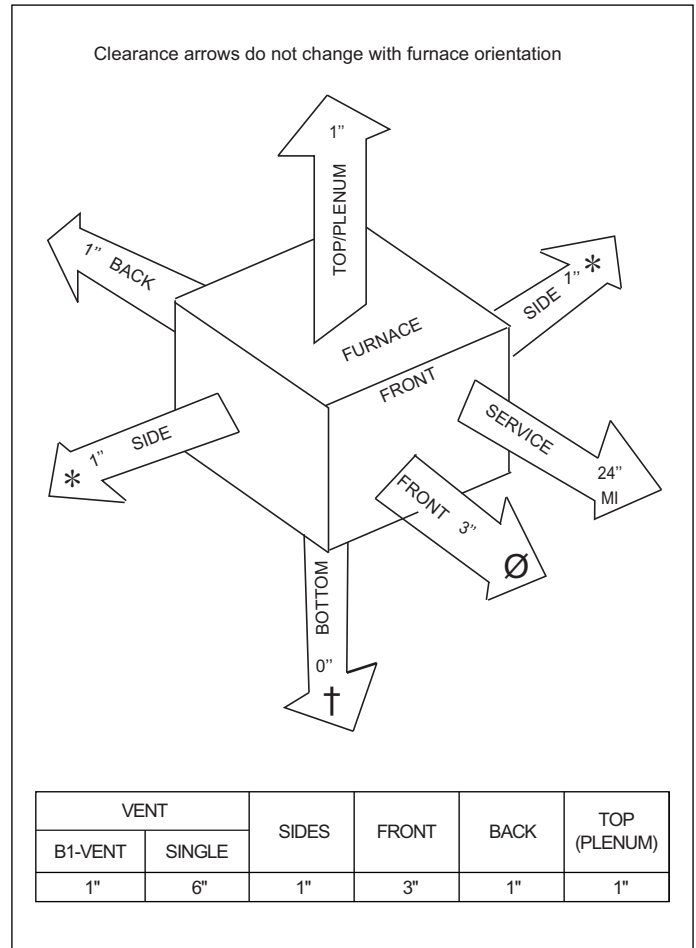

Figure 2 Minimum clearance from combustible construction

Downflow positions:

† Installation on non-combustible floors only. Installation on combustible flooring requires installation on field supplied sub-base.

∅ 18 inches front clearance required for alcove.

Horizontal installation in attic or crawl space

* Indicates supply or return sides when furnace is in the horizontal position. Line contact only permissible between lines formed by intersections of the side and back of the furnace cabinet and building joists, studs or frame.

A special, field supplied base is required for horizontal installations (refer to Section 7.3 "Horizontal Installation").

4 Codes and Standards

Follow all national and local codes and standards in addition to these instructions. The installation must comply with regulations of the serving gas supplier, local building, heating, plumbing, and other codes. In absence of local codes, the installation must comply with the national codes listed below and all authorities having jurisdiction. Follow all codes and standards for the following:

4.1 Safety

- ▶ National Fuel Gas Code (NFGC) NFPA 54-2006/ANSI Z223.1-latest edition and the Installation Standards, Warm Air Heating and Air Conditioning Systems ANSI/NFPA 90B

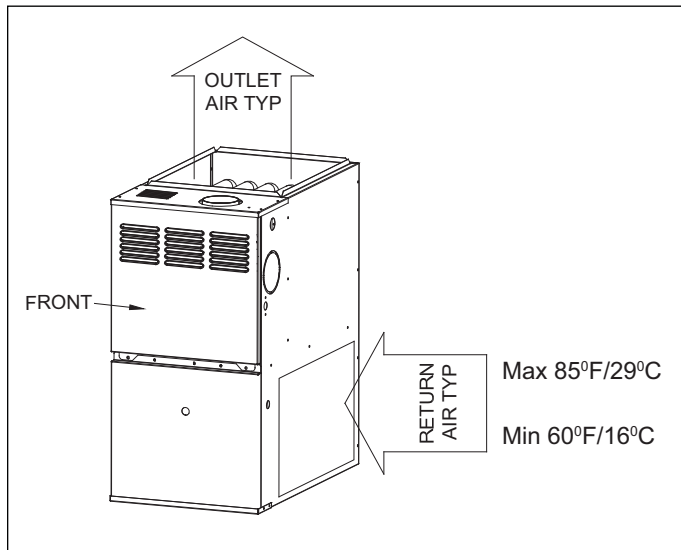

Figure 3 Return Air Temperature

4.2 General Installation

- ▶ Current edition of the NFGC and the NFPA 90B. For copies, contact the National Fire Protection Association Inc., 1 Batterymarch Park, Quincy, MA 02169; (www.nfpa.org) or for only the NFGC, contact the American Gas Association, 400 North Capital Street, NW, Suite 450, Washington, DC 20001 (www.aga.org)

4.3 Combustion and Ventilation Air

- ▶ Section 9.3 of the NFGC, NFPA 54/ANSI Z223.1-latest edition Air for Combustion and Ventilation

4.4 Duct Systems

- ▶ Air Conditioning Contractors Association (ACCA) Manual D, Sheet Metal and Air Conditioning Contractors National Association (SMACNA), or American Society of Heating, Refrigeration, and Air Conditioning Engineers (ASHRAE) 2001 Fundamentals Handbook Chapter 34 or 2000 HVAC Systems and Equipment Handbook Chapters 9 and 16

4.5 Acoustical Lining and Fibrous Glass Duct

- ▶ Current edition of SMACNA and NFPA 90B as tested by UL Standard 181 for Class I Rigid Air Ducts

4.6 Gas Piping and Gas Pipe Pressure Testing

- ▶ NFPA 54/ANSI Z223.1-latest edition Chapters 5,6, 7, and 8 and National Plumbing Codes

4.7 Electrical Connections

- ▶ National Electrical Code (NEC) ANSI/NFPA 70-latest edition

4.8 Electrical Power Supply

- ▶ Voltage: ANSI C84.1- latest edition (104-127 volt)

4.9 Venting

- ▶ NFGC NFPA 54/ANSI Z223.1-latest edition; Chapters 12 and 13

5 Electrostatic Discharge (ESD) Precautions Procedure



CAUTION: FURNACE RELIABILITY HAZARD

- ▶ Improper installation or service of furnace may cause premature furnace component failure.
- ▶ Electrostatic discharge can affect electronic components. Follow the electrostatic discharge precautions procedure listed below during furnace installation and servicing to protect the furnace electronic control. Precautions will prevent electrostatic discharges from personnel and hand tools which are held during the procedure. These precautions will help to avoid exposing the control board to electrostatic discharge by putting the furnace, the control board, and the person at the same electrostatic potential.

1. Disconnect all power to the furnace. Multiple disconnects maybe required. **DO NOT TOUCH THE CONTROL OR ANY WIRE CONNECTED TO THE CONTROL PRIOR TO DISCHARGING YOUR BODY'S ELECTROSTATIC CHARGE TO GROUND.**
2. To discharge your body's electrostatic charge to ground, firmly touch the clean, unpainted, metal surface of the furnace chassis which is close to the control board. Tools held in a person's hand during grounding will be satisfactorily discharged.
3. After touching the chassis, you may proceed to service the control board or connecting wires as long as you do nothing to recharge your body with static electricity (for example; DO NOT move or shuffle your feet, do not touch ungrounded objects, etc.).
4. If you touch ungrounded objects (and recharge your body with static electricity), firmly touch a clean, unpainted metal surface of the furnace again before touching control board or wires.

Use this procedure for installed and uninstalled (ungrounded) furnaces. In the case of control board replacement, before removing the replacement control board from its packaging, discharge your body's electrostatic charge to ground to protect the control from damage. If the control is to be installed in a furnace, follow steps 1 through 4 before bringing the control board or yourself in contact with the furnace. Put all used and new control boards into containers before touching ungrounded objects.

An ESD service kit (field supplied) may also be used to prevent ESD damage.

6 Location

6.1 General

This multipoise furnace is shipped in packaged configuration. Some assembly and modifications are required when used in any of the four applications. This furnace must:

- ▶ Be installed so the electrical components are protected from water.
- ▶ Not be installed directly on any combustible material other than wood flooring. Refer to Section 3 Fig 2. for required clearances.
- ▶ Downflow installation and horizontal installation in attics and crawl spaces have additional requirements. Refer to Section 7.
- ▶ Be located close to the chimney or vent and attached to an air distribution system. Refer to Section 7.6 "Air Ducts".
- ▶ Be provided ample space for servicing and cleaning. Always comply with minimum fire protection clearances shown on the furnace clearance to combustible label. Refer to Section 3, Fig 2.

The following types of furnace installations may require OUTDOOR AIR for combustion due to chemical exposures:

- ▶ Commercial buildings
- ▶ Buildings with indoor pools
- ▶ Laundry rooms
- ▶ Hobby or craft rooms, and
- ▶ Chemical storage areas



WARNING: CARBON MONOXIDE POISONING HAZARD

- ▶ Failure to follow this warning could result in personal injury or death, and unit component damage.
- ▶ Corrosive or contaminated air may cause failure of parts containing flue gas, which could leak into the living space. Air for combustion must not be contaminated by halogen compounds, which include fluoride, chloride, bromide, and iodide. These elements can corrode heat exchangers and shorten furnace life. Air contaminants are found in aerosol sprays, detergents, bleaches, cleaning solvents, salts, air fresheners, and other household products. Do not install furnace in a corrosive or contaminated atmosphere. Make sure all combustion and circulating air requirements are met, in addition to all local codes and ordinances.

If air is exposed to the following substances, it should not be used for combustion air, and outdoor air may be required for combustion:

- ▶ Permanent wave solutions
- ▶ Chlorinated waxes and cleaners
- ▶ Chlorine based swimming pool chemicals
- ▶ Water softening chemicals
- ▶ De-icing salts or chemicals
- ▶ Carbon tetrachloride
- ▶ Halogen type refrigerants
- ▶ Cleaning solvents (such as perchloroethylene)
- ▶ Printing inks, paint removers, varnishes, etc.
- ▶ Hydrochloric acid
- ▶ Cements and glues
- ▶ Antistatic fabric softeners for clothes dryers
- ▶ Masonry acid washing materials

All fuel-burning equipment must be supplied with air for fuel combustion. Sufficient air must be provided to avoid negative pressure in the equipment room or space. A positive seal must be made between the furnace cabinet and the return-air duct to prevent pulling air from the burner area and from draft safeguard opening. Also see Section 7.6 "Air Ducts".

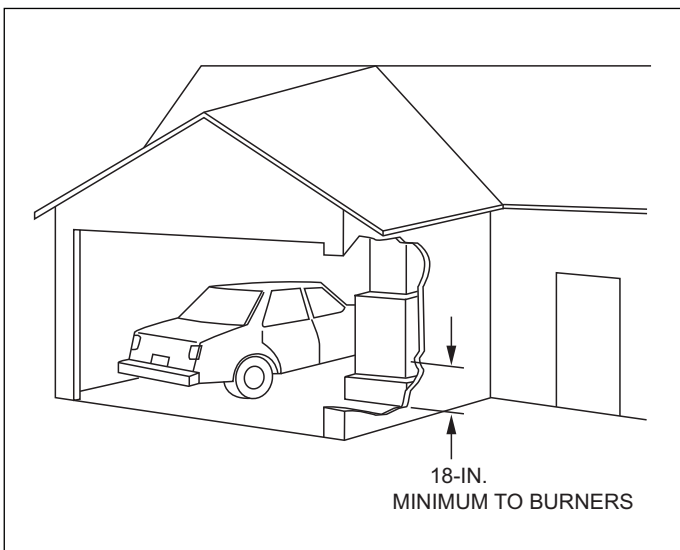

Figure 4 Installation in a garage



WARNING: FIRE, INJURY OR DEATH HAZARD

- ▶ When the furnace is installed in a residential garage, the burners and ignition sources must be located at least 18 inches above the floor. The furnace must be located or protected to avoid damage by vehicles. When the furnace is installed in a public garage, airplane hangar, or other building having a hazardous atmosphere, the furnace must be installed in accordance with the NFPA. (See Fig. 4).



CAUTION: INJURY AND/OR PROPERTY DAMAGE HAZARD

- ▶ Improper use or installation of this furnace may cause premature furnace component failure. This gas furnace may be used for heating buildings under construction provided that:
 - The furnace is permanently installed with all electrical wiring, piping, venting and ducting installed according to these installation instructions. A return air duct is provided, sealed to the furnace casing, and terminated outside the space containing the furnace. This prevents a negative pressure condition as created by the circulating air blower, causing a flame rollout and/or drawing combustion products into the structure.
 - The furnace is controlled by a thermostat. It may not be "hot wired" to provide heat continuously to the structure without thermostatic control.
 - Clean outside air is provided for combustion. This is to minimize the corrosive effects of adhesives, sealers and other construction materials. It also prevents the entrainment of drywall dust into combustion air, which can cause fouling and plugging of furnace components.
 - The temperature of the return air to the furnace is maintained between 60°F (16°C) and 85°F (29°C), with no evening setback or shutdown.
 - The use of the furnace while the structure is under construction is deemed to be intermittent operation per our installation instructions.
 - The air temperature rise is within the rated rise range on the furnace rating plate, and the gas input rate has been set to the nameplate value.
 - The filters used to clean the circulating air during the construction process must be either changed or thoroughly cleaned prior to occupancy.
 - The furnace, ductwork and filters are cleaned as necessary to remove drywall dust and construction debris from all HVAC system components after construction is completed.
 - Verify proper furnace operating conditions including ignition, gas input rate, air temperature rise, and venting according to these installation instructions.

7 Installation

This furnace can be installed in upflow, downflow, or horizontal orientations. (see Section 7.4, Fig 12-18).

7.1 Upflow Installation

Bottom return air inlet

These furnaces are shipped with the bottom closure panel installed in bottom return-air opening. Remove and discard this panel when bottom return air is used. To remove bottom closure panel, perform the following:

1. Tilt or raise furnace and remove the screw holding bottom filler panel. (See Fig. 5.)
2. Remove bottom closure panel.

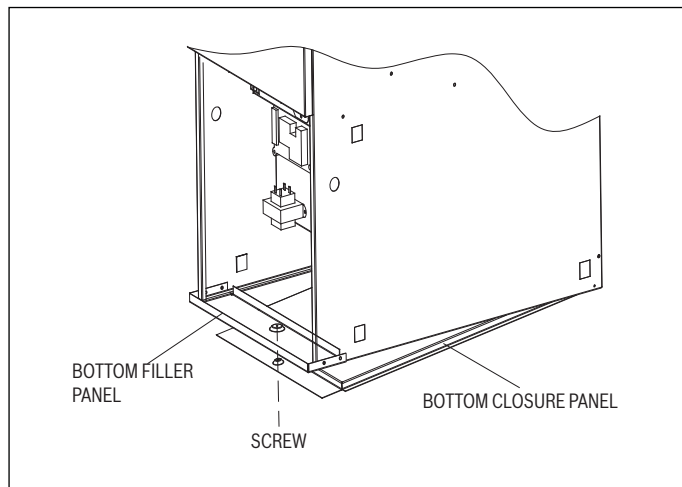

Figure 5 Removing bottom closure panel

Side return air inlet

These furnaces are shipped with bottom closure panel installed in bottom return-air opening. This panel **MUST** be in place if only side return air is used.

i Side return-air openings can be used in UPFLOW and most HORIZONTAL configurations. Do not use side return-air openings in DOWNFLOW configuration.

i These furnaces come standard with knockout holes to aid in right/left return configurations (refer to Fig. 19). To do this, knockout the holes and cut the sheet metal and insulation accordingly.

7.2 Downflow Installation

i For downflow applications, this furnace is approved for use on combustible flooring when any one of the following 3 (field supplied) accessories are used:

- ▶ Subbase
- ▶ Cased Coil Assembly
- ▶ Coil Box

1. Determine specific application being installed from Table 2.
2. Construct hole in floor per Table 2 and Fig. 6.
3. Construct plenum to dimensions specified in Table 2 and Fig. 6.
4. If downflow subbase is used, install as shown in Fig. 7.
5. If Coil Assembly or Coil Box is used, install as shown in Fig. 8.

i It is recommended that the supply-air duct flanges be completely folded over or removed from furnace when installing the furnace on a standard cased coil or coil box. To remove the supply-air duct flange, use wide duct pliers or hand seamers to bend flange. Be careful of sharp edges.

Bottom return air inlet

Do not use side return openings in downflow configuration. These furnaces are shipped with bottom closure panel installed in bottom return-air opening. Remove and discard this panel when bottom return air is used. See 7.1 and Fig. 5 for bottom closure panel removal instructions.

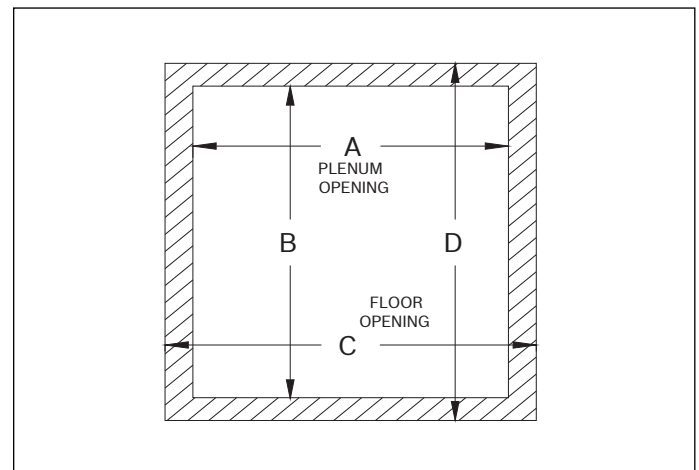

Figure 6 Floor and plenum opening dimensions

FURNACE CABINET WIDTH	APPLICATION	PLENUM OPENING		FLOOR OPENING	
		A*	B*	C*	D*
14-1/2	Downflow applications on noncombustible flooring	13-3/16	19-11/16	13-13/16	20-5/16
	Downflow applications on combustible flooring using subbase	12-3/16	19	13	19-3/4
	Downflow applications on combustible flooring with industry standard (field supplied) coil assembly or coil box	13-3/16	19-3/16	13-13/16	19-13/16
17-1/2	Downflow applications on noncombustible flooring	16-3/16	19-11/16	16-13/16	20-5/16
	Downflow applications on combustible flooring using subbase	15-3/16	19	16	19-3/4
	Downflow applications on combustible flooring with industry standard (field supplied) coil assembly or coil box	16-3/16	19-3/16	16-13/16	19-13/16
21	Downflow applications on noncombustible flooring	19-11/16	19-11/16	20-5/16	20-5/16(
	Downflow applications on combustible flooring using subbase	18-11/16	19	19-1/2	19-3/4
	Downflow applications on combustible flooring with industry standard (field supplied) coil assembly or coil box	19-11/16	19-3/16	20-5/16	19-13/16
24-1/2	Downflow applications on noncombustible flooring	23-3/16	19-11/16	23-13/16	20-5/16
	Downflow applications on combustible flooring using subbase	22-3/16	19	23	19-3/4
	Downflow applications on combustible flooring with industry standard (field supplied) coil assembly or coil box	19-11/16	19-3/16	20-5/16	19-13/16

Table 2 Open dimensions for downflow applications - inch

* As seen in Fig. 6

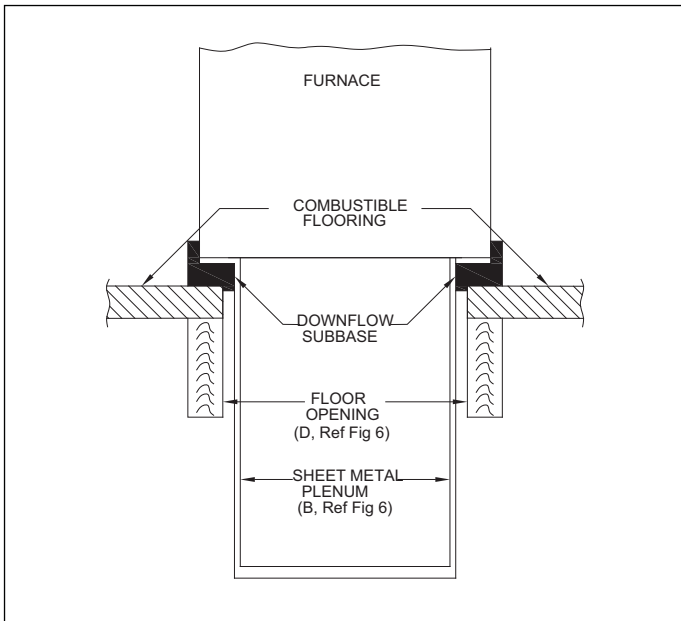

Figure 7 Furnace, plenum, and subbase installed on a combustible floor

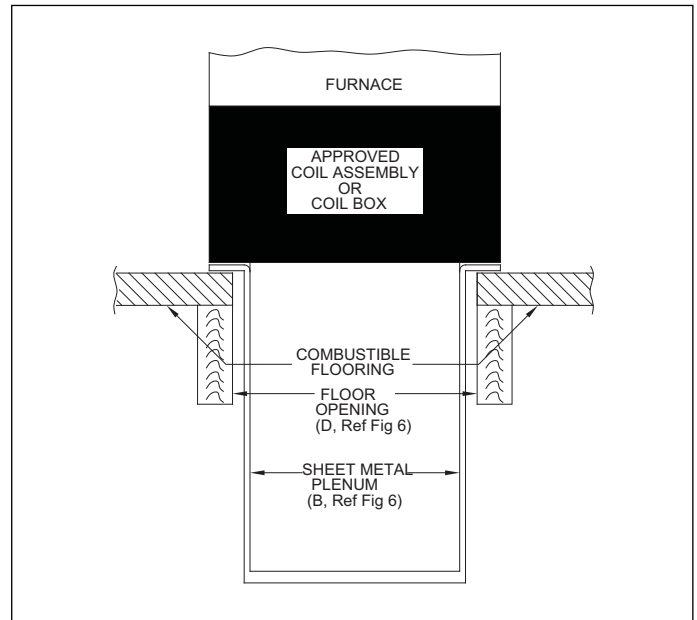

Figure 8 Furnace, plenum, and coil assembly or coil box installed on a combustible floor

7.3 Horizontal Installation



WARNING: FIRE, EXPLOSION, AND CARBON MONOXIDE POISONING HAZARD

- ▶ Do not install the furnace on its back or hang furnace with control compartment facing downward. Safety control operation will be adversely affected. Never connect return-air ducts to the back of the furnace.

The furnace can be installed horizontally in an attic or crawl space on bottom or either the left-hand (LH) or right-hand (RH) side. The furnace can be hung from floor joists, rafters or trusses or installed on a non-combustible platform, blocks, bricks or a pad.

Suspended furnace support

The furnace may be supported under each end with threaded rod, angle iron or metal plumber's strap as shown (See Fig. 9 and 10). Secure angle iron to bottom of furnace as shown. Heavy-gauge sheet metal straps (plumber's straps) may be used to suspend the furnace from each bottom corner. To prevent screws from pulling out, secure 2 #8 x 3/4-inch screws into each side and 2 #8 x 3/4-inch screws in the bottom of the furnace cabinet for each strap (See Fig. 9 and 10). If the screws are attached to ONLY the furnace sides and not the bottom, the straps must be vertical against the furnace sides and does not pull away from the furnace sides, so that the strap attachment screws are not loaded in shear for reliable support.

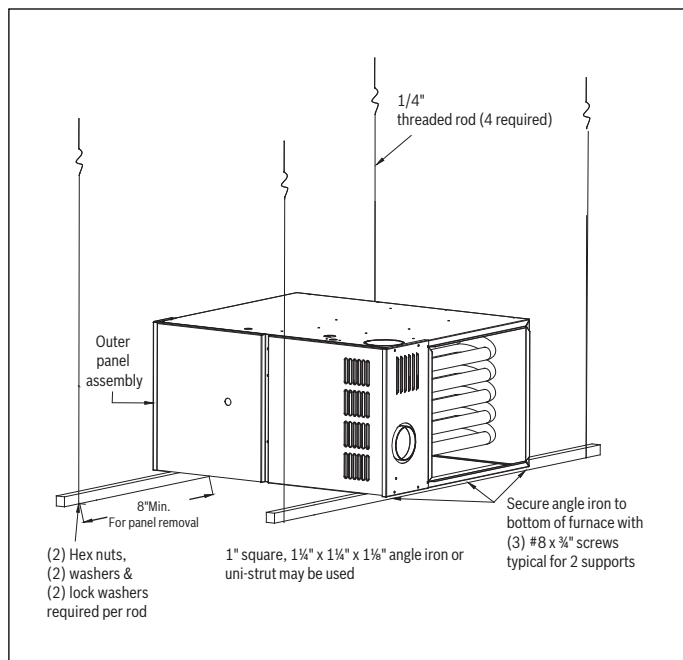

Figure 9 Horizontal unit suspension with angle irons/threaded rods

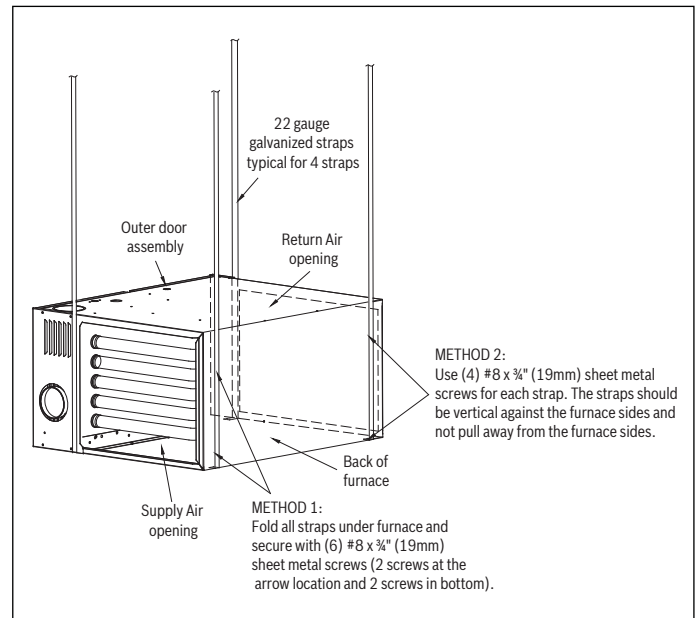

Figure 10 Horizontal suspension with straps

Platform furnace support

Construct working platform at location where all required furnace clearances are met (Section 3, Fig. 2). For furnaces with 1-inch clearance requirement on side, set furnace on noncombustible blocks, bricks or angle irons. For crawl space installations, if the furnace is not suspended from the floor joists, the ground underneath furnace must be level and the furnace set on blocks or bricks.

Roll-out protection

Provide a piece of sheet metal for flame roll-out protection in front of burner area for furnaces closer than 12-inch above the combustible deck or suspended furnaces closer than 12-inch to joists. The sheet metal MUST extend underneath the furnace cabinet by 12-inch with the burner access panel removed.

The bottom closure panel on furnaces of widths 12 inch and larger may be used for flame roll-out protection when bottom of furnace is used for return air connection. See Fig. 11 for proper orientation of roll-out shield.

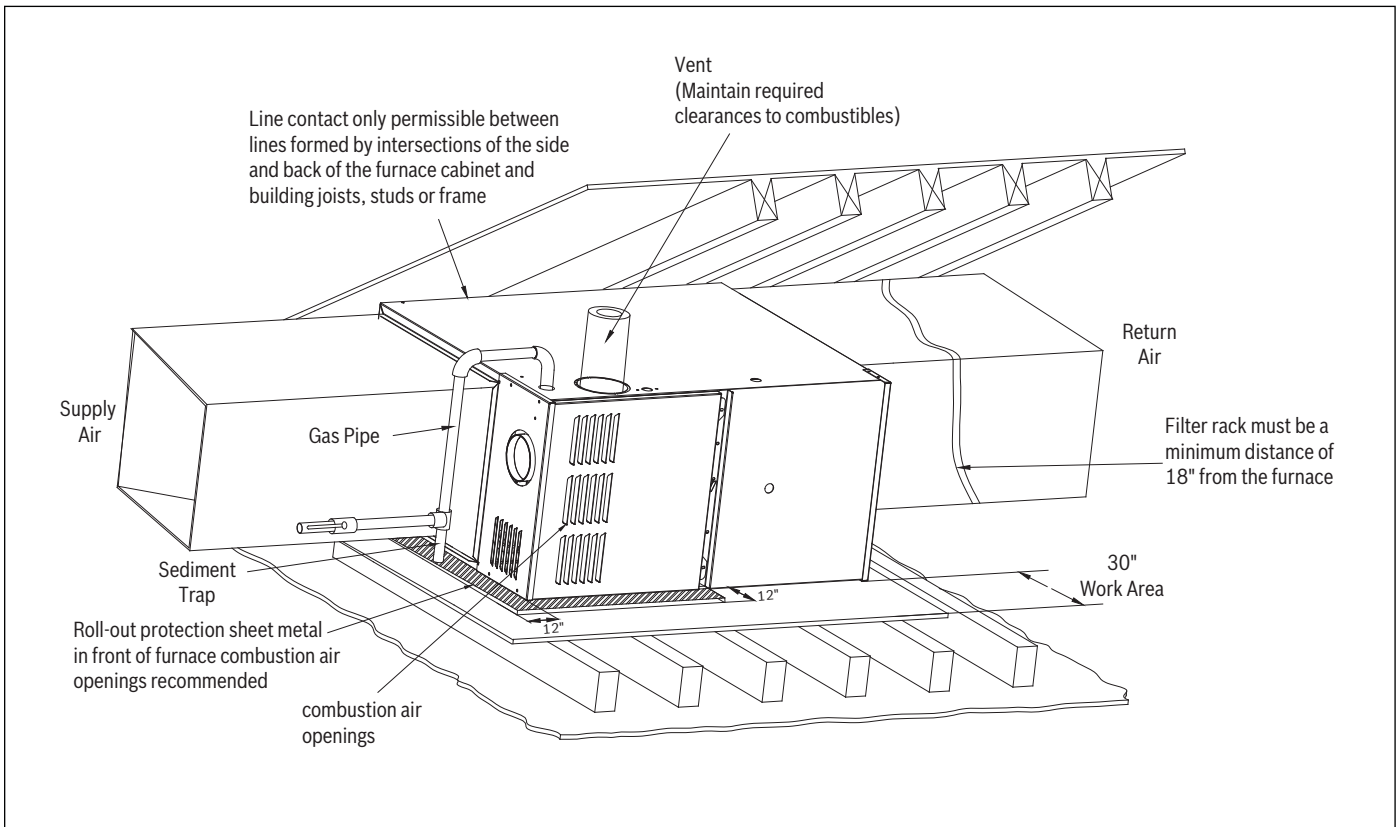

Figure 11 Typical attic or crawl space installation

7.4 Furnace Installation Orientations

Vent the furnace with the appropriate connector as shown in Fig. 12-18.

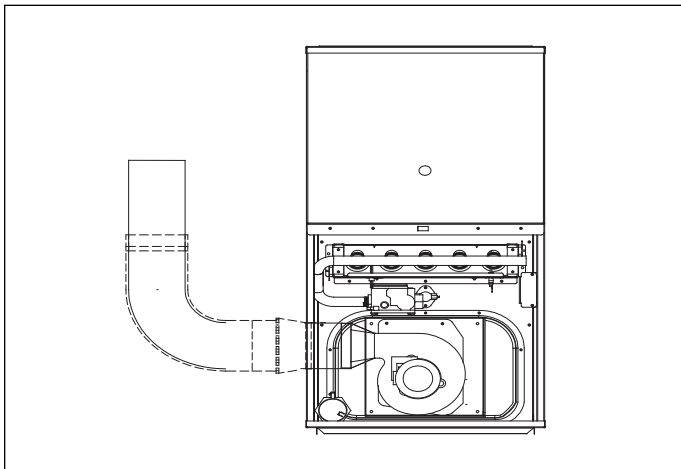

Figure 12 Downflow application - vent elbow up then left

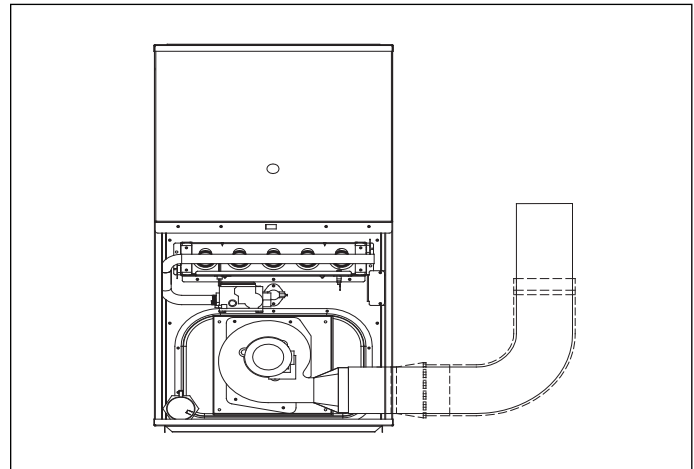

Figure 13 Downflow application - vent elbow up then right

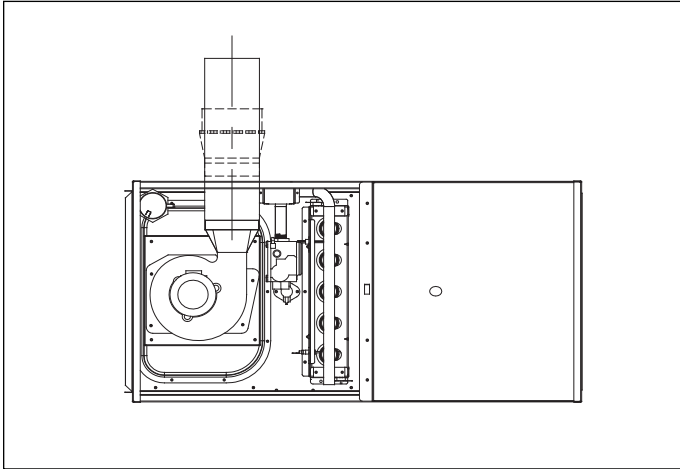

Figure 14 Horizontal left application - vent elbow up

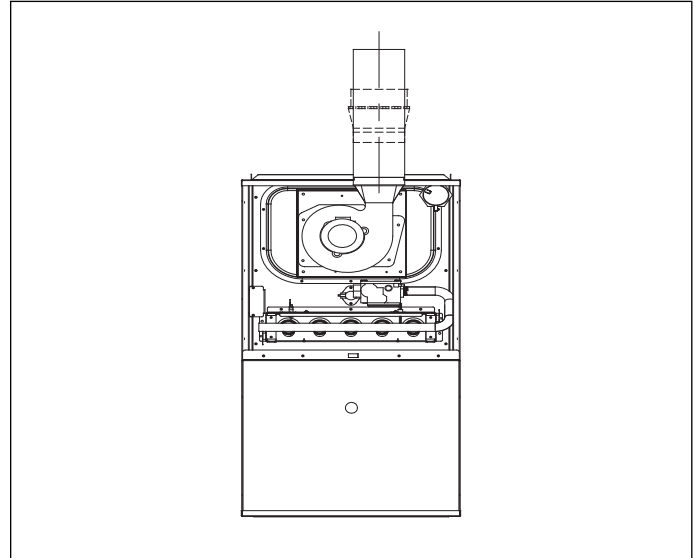

Figure 17 Upflow application - vent elbow up

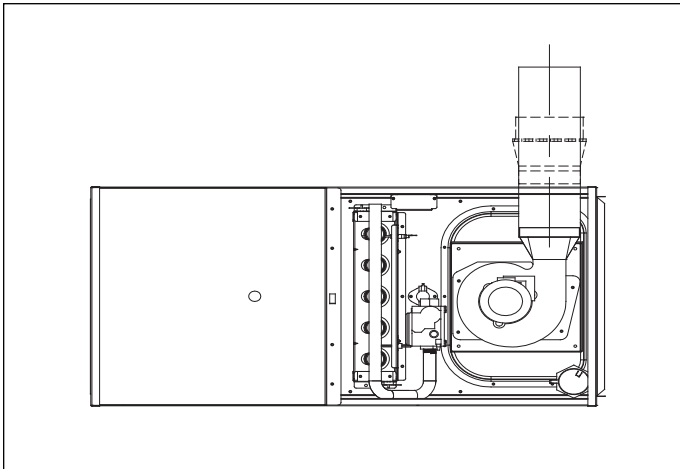

Figure 15 Horizontal right application - vent elbow up

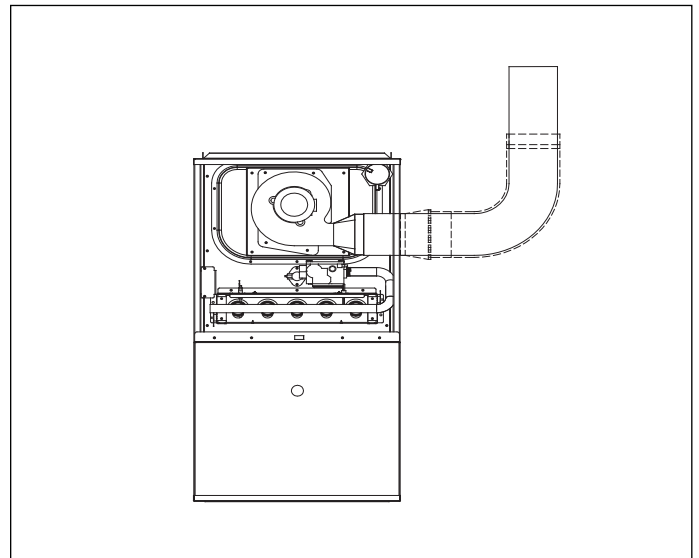

Figure 18 Upflow application - vent elbow right

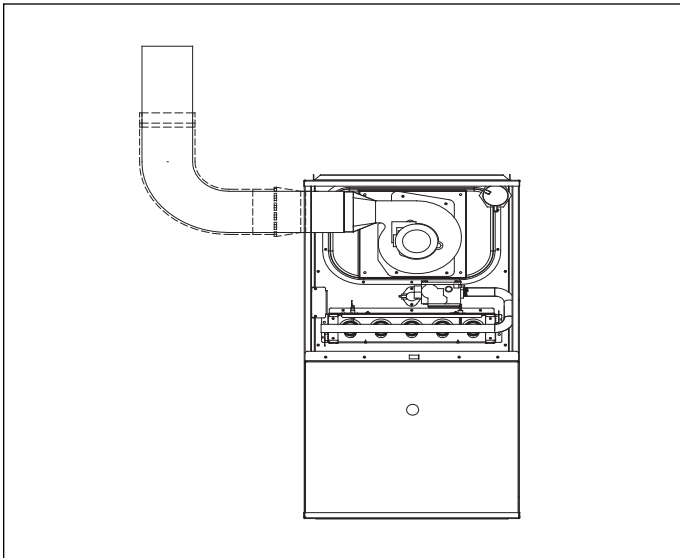

Figure 16 Upflow application - vent elbow left

7.5 Filter Arrangement



CAUTION:

- ▶ Never install a filter on the supply air side. Filters should always be installed on return air side of system.



WARNING: CARBON MONOXIDE AND POISONING HAZARD

- ▶ Never operate a furnace without a filter or with filter access door removed.

Filter size

The Bosch 80% AFUE Gas Furnace BGS80 series does not include a filter from the manufacturer. The filter and filter rack must be field supplied and field installed. A high velocity filter is recommended, see recommended filter size and type in Table 3 on the following page. One of the most common causes of furnace malfunctions is a blocked or dirty filter. The filter must be inspected monthly for dirt accumulation and replaced if necessary.

Filter type

Air velocity through disposable filters may not exceed 300 feet per minute (FPM). All velocities over this require the use of high velocity filters. If a normal speed disposable filter is used and air speed exceeds 300 feet per minute (FPM), two side returns or one side return and the bottom return may be needed. For airflow, refer to Table 4, page 19.



CAUTION:

- ▶ If disposable filters are used, air passage through filters should be increased to twice the size of original air opening by using a transition duct or using two filters in V shape (see Fig. 19) in normal duct size.

Side return

Locate the 4 cutout locations. These indicate the size of the cut-out to be made in the furnace side panel. Refer to Fig 19, "Side Return Cutout Markings".

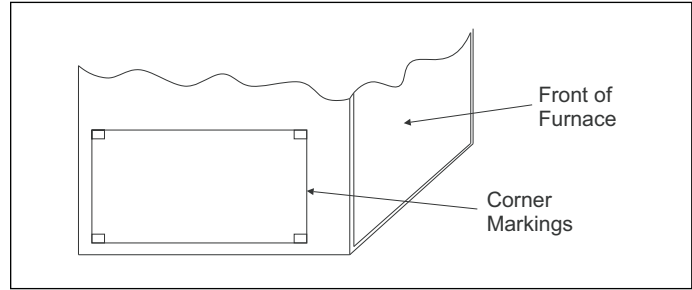

Figure 20 Side return cutout markings

Install the side filter rack (field supplied) following the instructions provided with that accessory. If a filter(s) is provided at another location in the return air system, the duct work may be directly attached to the furnace side panel.



Some field supplied accessories such as electronic air cleaners and pleated media filters may require a larger side opening. Follow the instructions supplied with those accessories for side opening requirements.

Downflow filters

Downflow furnaces typically are installed with the filters located above the furnace, extending into the return air plenum or duct. Any branch duct (rectangular or round duct) attached to the plenum must attach to the vertical plenum above the filter.

Bottom Return filters

Filter(s) may be located in the duct system outside the furnace using an external duct filter box attached to the furnace plenum or at the end of the duct in a return filter grille(s). The use of straps and/or supports is required to support the weight of the external filter box.

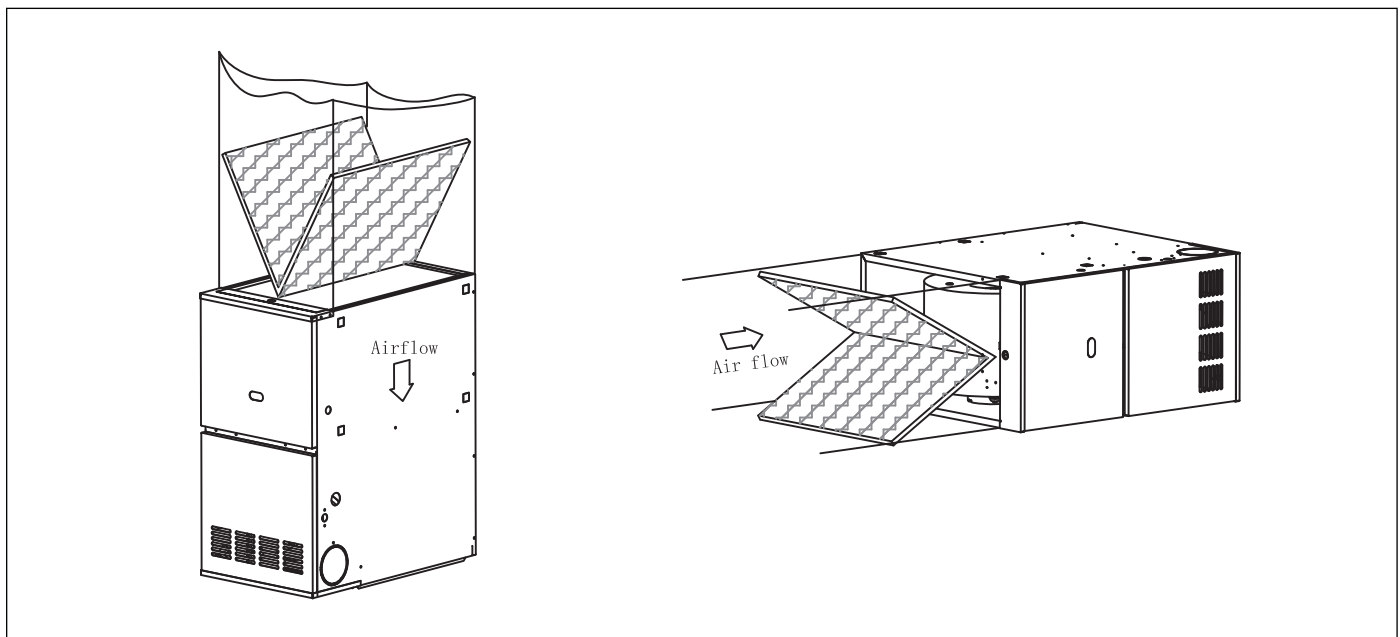

Figure 19

7.6 Air Ducts

General requirements

The duct system should be designed and sized according to accepted national standards such as those published by: Air Conditioning Contractors Association (ACCA), Sheet Metal and Air Conditioning Contractors National Association (SMACNA) or American Society of Heating, Refrigerating and Air Conditioning Engineers (ASHRAE) or consult The Air Systems Design Guidelines reference tables available from your local distributor. The duct system should be sized to handle the required system design CFM at the design external static pressure. The furnace airflow rates are provided in Table 4 "Air Delivery - CFM (Without Filter)".

When a furnace is installed so that the supply ducts carry air circulated by the furnace to areas outside the space containing the furnace, the return air shall also be handled by duct(s) sealed to the furnace casing and terminating outside the space containing the furnace.

Secure ductwork with the proper fasteners for type of ductwork used. Seal supply and return-duct connections to furnace with code approved tape or duct sealer.



Flexible connections should be used between duct work and furnace to prevent transmission of vibration. Duct work passing through unconditioned space should be insulated and sealed to enhance system performance. When air conditioning is used, a vapor barrier is recommended.

Maintain a 1-inch clearance between combustible materials and the supply air ductwork for a distance of 36 inch horizontally from the furnace. See NFPA 90B or local code for further requirements.

Ductwork acoustical treatment



Metal duct systems that do not have a 90 degree elbow and 10 ft. of main duct to the first branch take-off may require internal acoustical lining. As an alternative, fibrous duct work may be used if constructed and installed in accordance with the latest edition of SMACNA construction standard on fibrous glass ducts. Both acoustical lining and fibrous duct work shall comply with NFPA 90B as tested by UL Standard 181 for Class 1 Rigid air ducts.

Supply air connections

For a furnace not equipped with a cased coil, the outlet duct shall be provided with a removable access panel. This opening shall be accessible when the furnace is installed and shall be of such a size that the heat exchanger can be visually checked for possible damage using light assistance or a probe that can be inserted for sampling the airstream. The cover attachment shall prevent leaks.

Upflow and horizontal furnaces

Connect supply-air duct to flanges on furnace supply-air outlet. Bend flange upward to 90° with wide duct pliers. The supply-air duct must be connected to ONLY the furnace supply-outlet-air duct flanges or cased coil cabinet (when used).

NOTICE:

- ▶ DO NOT cut main furnace cabinet side to attach supply air duct, humidifier, or other accessories. All accessories MUST be connected to duct external to main furnace cabinet.



For horizontal applications, the top-most flange may be bent past 90 degrees to allow the evaporator coil to hang on the flange temporarily while the remaining attachment and sealing of the coil are performed.

Downflow furnaces

Connect supply-air duct to supply-air outlet on furnace. Bend flange inward past 90° with wide duct pliers. The supply-air duct must be connected ONLY to the furnace supply outlet or cased coil cabinet (when used). When installed on combustible material, supply-air duct must be connected ONLY to the subbase (field supplied) or a industry standard coil box.

NOTICE:

- ▶ DO NOT cut furnace cabinet casing to attach supply side air duct, humidifier, or other accessories. All accessories MUST be connected to duct external to furnace cabinet.

Furnace cabinet width	Filter size		Filter type
	Side return	Bottom return	
14-1/2	16X25	14X25	High Velocity (600 FPM)
17-1/2	16X25	16X25	High Velocity (600 FPM)
21	16X25	20X25	High Velocity (600 FPM)
24.5	16X25	24X25	High Velocity (600 FPM)

Table 3 Manufacturer recommended high velocity filter sizes - Inch

Furnace size	Return-air inlet	Speed	External static pressure (in. WC)									
				0.2	0.3	0.4	0.5	0.6	0.7	0.8	0.9	1.0
50A	Bottom or Sides	H	1460	1420	1370	1320	1260	1200	1120	1040	950	860
		H-M	1210	1170	1140	1090	1030	970	910	840	760	780
		**M-L	1080	1050	1010	960	960	870	810	750	670	550
		L	780	760	730	700	670	630	580	510	390	----
80B	Bottom or Sides	H	1880	1810	1730	1650	1580	1500	1430	1330	1210	990
		**H-M	1680	1620	1560	1500	1430	1350	1270	1160	1020	800
		M-L	1440	1390	1340	1290	1240	1170	1080	970	810	640
		L	1190	1150	1110	1070	1020	950	870	750	640	530
100C	Bottom or Sides	H	2180	2070	1960	1890	1810	1720	1620	1500	1370	1230
		**H-M	1760	1710	1660	1600	1520	1460	1360	1260	1140	1130
		M-L	1570	1540	1490	1440	1380	1310	1240	1150	1040	910
		L	1410	1370	1340	1310	1250	1200	1130	1040	940	810
120D	Bottom or Sides	H	2320	2240	2160	2060	1980	1890	1780	1670	1540	1360
		**H-M	1790	1750	1700	1660	1610	1540	1460	1360	1220	1060
		M-L	1550	1520	1490	1450	1430	1360	1300	1210	1110	960
		L	1360	1350	1330	1310	1280	1220	1160	1070	960	830

Table 4 Air Delivery - CFM (Without Filter) * **

* A filter is required for each return-air inlet. Airflow performance included 3/4-inch washable filter media such as contained in field supplied accessory filter rack. To determine airflow performance with this filter, assume an additional 0.1 in. WC available external static pressure.

** Manufacturer default speed tap for heating.

8 Vent System

8.1 Vent Connections

Fig. 21 “Combustion Air Inducer” below shows the furnace as it is shipped from the factory. To convert to a horizontal or downflow position, remove the four screws that secure the inducer assembly and rotate 90°, being careful not to damage the gasket. Reinstall screws. Remove knockout from appropriate vent outlet location on the cabinet. Cut insulation in cabinet to the same size as the hole provided.

i In downflow applications, do not block the combustion air inlet. The furnace must be installed on a subbase, cased coil assembly, or coil box to allow combustion air to enter the burner compartment.

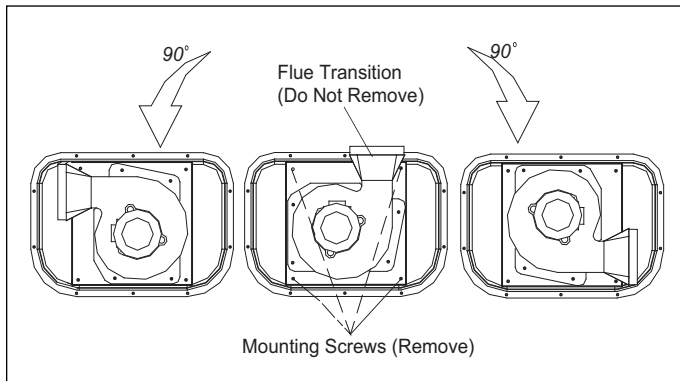

Figure 21 Combustion Air Inducer

CATEGORY 1 - 450 °F. MAX. VENT TEMP.

The venting system must be installed in accordance with Section 5.3 Air for combustion and Ventilation of the National Fuel Gas Code Z223.1/NFPA 54 (latest edition) or National Gas and Propane Codes (latest edition) or applicable provisions of the local building code and these instructions.

The furnace shall be connected to a type B vent connector. The furnace shall not be connected to a chimney flue serving a separate appliance designed to burn solid fuel. Single-wall vent pipe is not allowed.

It is recommended that the appliance be installed in a location where the space temperature is 32° F (0° C) or higher. If the appliance is installed in a location where the temperature is below 32° F (0° C), the combustion byproducts could condense causing damage to the appliance's heat exchanger.

This appliance may be common vented with another gas appliance for residential installations as allowed by the federal and local codes and standards.

8.2 Venting

Category I venting consists of vertically venting one or more appliances in B-vent or B-vent connectors. Type B-vent systems extend in a general vertical direction and do not contain offsets exceeding 45°. A vent system with no more than one 60° offset is permitted.



Category I vent materials are found with older appliances. Single-wall galvanized pipe (26 gauge) is only used as a connector on 70 percent AFUE and lower gas appliances and all oil appliances. Masonry will use vitreous clay liner. In some cases, Transrite has been used, which may contain asbestos and does not meet any venting requirements. “B” vent is double-walled and must be used for installation of this furnace. It is galvanized steel on the outside, with an aluminum inner pipe. B vent is rated only for gas appliances. It is used as a vent connector for all 78 percent and 80 percent AFUE appliances. It may not run outside of the building and may be used as a liner in an existing flue chase.

8.3 Venting Into a Masonry Chimney

If the chimney is oversized, the liner is inadequate, or flue-gas condensation is a problem in your area, consider using the chimney as a pathway or chase for type “B” vent or flexible vent liner. If flexible liner material is used, size the vent using the “B” vent tables, then reduce the maximum capacity by 20%. Masonry Chimney Kit from a qualified supplier or brand may be used with these furnaces (upflow model furnaces only) to allow venting into a masonry chimney. The installation shall be in accordance with codes and the regulations of the local gas company.

8.4 Air for Combustion and Ventilation

8.4.1 Ambient Combustion Air Supply

This furnace will draw the air required for combustion from within the space surrounding the appliance and from areas or rooms adjacent to the space surrounding the appliance. Combustion air may be from the space in a non-confined location or it may be brought into the furnace area from the outdoors through permanent openings or ducts. A single, properly sized pipe from the furnace vent connector to the outdoors must be provided. For upflow models combustion air is brought into the furnace through the unit top panel opening.

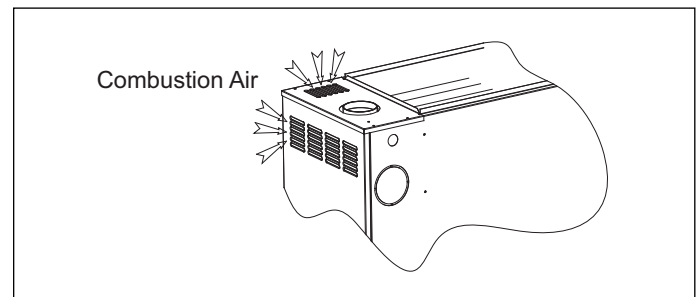

Figure 22 Combustion Airflow Path Through The Furnace Casing to the Burner Box



WARNING:

- ▶ This type of installation requires that the supply air to the appliance(s) be of a sufficient amount to support all of the appliance(s) in the area. Operation of a mechanical exhaust, such as an exhaust fan, kitchen ventilation system, clothes dryer or fireplace may create conditions requiring special attention to avoid unsatisfactory operation of gas appliances. A venting problem or a lack of supply air will result in a hazardous condition, which can cause the appliance to soot and generate dangerous levels of CARBON MONOXIDE, which can lead to serious injury, property damage, and/or death.

An unconfined space is an area with more than 50 cu.ft per 1,000Btu/hr (0.2928 kW) input rating for all of the appliances installed in that area. Rooms communicating directly with the space containing the appliances through openings not furnished with doors, are considered a part of the unconfined space.

In unconfined spaces (see Figure 23) in buildings, infiltration may be adequate to provide air for combustion ventilation and dilution of flue gases. However, in buildings of tight construction (for example, weather stripping, heavily insulated, caulked, vapor barrier, etc.), additional air may need to be provided using the methods described in the "Equipment Located in Confined Spaces" section below.

A confined space is an area with less than 50 cu. ft per 1,000 Btu/hr (0.2928 kW) input rating for all of the appliances installed in that area. The following must be considered to obtain proper air for combustion and ventilation in confined spaces.

WARNING:

- ▶ When a Category I furnace is removed or replaced, the original venting system may no longer be correctly sized to properly vent the attached appliances.

An improperly sized vent system can cause CARBON MONOXIDE to spill into the living space causing personal injury, and/or death.

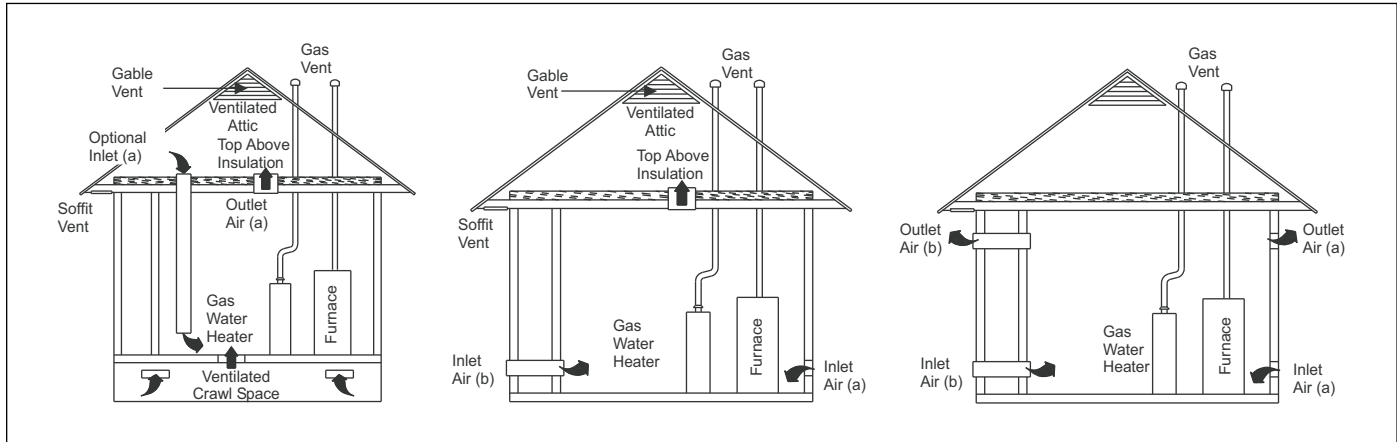

Figure 23 Outside and Ambient Combustion Air

Equipment Located in Confined Spaces:

a) All air from inside the building:

The confined space shall be provided with two permanent openings communicating directly with an additional room(s) of sufficient volume so that the combined volume of all spaces meets the criteria. The total input of all gas utilization equipment installed in the combined space shall be considered in making this determination. Each opening shall have a minimum free area of 1 square inch per 1,000 BTU per hour of the total input rating of all gas utilization equipment in the confined space. One opening shall be within 12 inches of the top and one within 12 inches of the bottom of the enclosure (See Table 5).

BTUH Input Rating	Minimum Free Area in Square Inch Required for Each Opening
50,000	50 in ²
80,000	80 in ²
100,000	100 in ²
120,000	120 in ²

Table 5 Minimum Area in Square Inch Required for Each Opening

b) All air from outdoors:

BTUH Input Rating	Minimum Free Area Required for Each Opening		
	Horizontal Duct (2,000 BTUH)	Vertical Duct or Opening to Outside (4,000 BTUH)	Round Duct (4,000 BTUH)
50,000	25 in ²	12.5 in ²	4"
80,000	40 in ²	20 in ²	5"
100,000	50 in ²	25 in ²	6"
120,000	60 in ²	30 in ²	7"

Table 6 Minimum Area in Square Inch Required for Each Opening

EXAMPLE: Determining Free Area.

Appliance 1 Appliance 2 Total Input
 100,000 + 30,000 = (130,000 : 4,000) = 32.5 Sq. In. Vertical

Appliance 1 Appliance 2 Total Input
 100,000 + 30,000 = (130,000 : 2,000) = 65 Sq. In. Horizontal

8.5 Air Supply Openings and Ducts

- Two permanent openings, one within 12 in. of the top and one within 12 in. of the bottom of the confined space, shall communicate directly or by means of ducts with the outdoors, crawl spaces or attic spaces.
- One permanent opening, commencing within 12 in. of the top of the enclosure shall be permitted where the equipment has clearances of at least 1 in. from the sides and back and 6 in. from the front of the appliance. The opening shall communicate directly with the outdoors and shall have a minimum free area of:
 - 1 square inch per 3000 Btu per hour of the total input rating of all equipment located in the enclosure.
 - Not less than the sum of all vent connectors in the confined space.
- The duct shall be at least the same cross-sectional area as the free area of the air supply inlet opening to which it connects.
- The blocking effects of louvers, grilles and screens must be given consideration in calculating free area. If the free area of a specific louver or grille is not known, refer to Table 7, "Estimated Free Area" to estimate free area.

Wood or Metal Louvers or Grilles	Wood 20-25% Metal 60-70%
Screens	1/4" mesh or larger 100%

Table 7 Estimated Free Area

- An opening may be used in lieu of a duct to provide the outside air supply to an appliance unless otherwise permitted by the authority having jurisdiction or applicable local or federal codes. The opening shall be located within 12" horizontally from the burner level of the appliance. Refer to Section 8.4 "Air for Combustion and Ventilation" for additional information and safety check procedures.

8.6 Ventilated Combustion Air

The ventilated attic space or a crawl space from which the combustion air is taken must comply with the requirements specified in Section 8.4 "Air for Combustion and Ventilation" in this instruction or in Section 5.3 "Air for Combustion and Ventilation" of the National Fuel Gas Code, ANSI Z223.1 (latest edition). This type of installation requires two properly sized pipes. One brings combustion air from a properly ventilated attic space or crawl space and a second pipe that extends from the furnace vent connection (top right of unit) to the exterior of the building.

8.7 Vent and Supply (Outside) Air Safety Check Procedure

For Category I furnaces, vent installations shall be in accordance with Parts 7 and 11 of the National Fuel Gas Code, ANSI Z223.1/NFPA 54 and/or Section 7, Natural Gas and Propane Installation Codes, the local building codes, and the furnace and vent manufacturer's instructions.

Multi-story or common venting systems are permitted and must be installed in accordance with the National Fuel Gas Code, ANSI Z223.1/NFPA 54, Natural Gas and Propane Installation Codes, and the manufacturer's instructions. Vent connectors serving Category I furnaces shall not be connected into any portion of mechanical draft systems operating under positive pressure. Horizontal portions of the venting system shall be supported to prevent sagging using hangers or perforated straps and must slope upwards not less than 1/4" per foot from the furnace to the vent terminal.

It is recommended that you follow the venting safety procedure below. This procedure is designed to detect an inadequate ventilation system that can cause the appliances in the area to operate improperly causing unsafe levels of carbon monoxide or an unsafe condition to occur.



WARNING: CARBON MONOXIDE POISONING HAZARD

Failure to follow the steps outlined below for each appliance connected to the venting system being placed into operation could result in carbon monoxide poisoning or death. The following steps shall be followed for each appliance connected to the venting system being placed into operation, while all other appliances connected to the venting system are not in operation:

- Seal any unused openings in the venting system.
- Inspect the venting system for proper size and horizontal pitch, as required in the National Fuel Gas Code, ANSI Z223.1/NFPA 54 and these instructions. Determine that there is no blockage or restriction, leakage, corrosion and other deficiencies which could cause an unsafe condition.
- As far as practical, close all building doors and windows and all doors between the space in which the appliance(s) connected to the venting system are located and other spaces of the building.
- Close fireplace dampers.
- Turn on clothes dryers and any appliance not connected to the venting system. Turn on any exhaust fans, such as range hoods and bathroom exhausts, so they are operating at maximum speed. Do not operate a summer exhaust fan.
- Follow the lighting instructions. Place the appliance being inspected into operation. Adjust the thermostat so appliance is operating continuously.
- Test for spillage from draft hood equipped appliances at the draft hood relief opening after 5 minutes of main burner operation. Use the flame of a match or candle.
- If improper venting is observed during any of the above tests, the venting system must be corrected in accordance with the National Fuel Gas Code, and ANSI Z223.1/NFPA 54.
- After it has been determined that each appliance connected to the venting system properly vents when tested as outlined above, return doors, windows, exhaust fans, fireplace dampers and any other gas-fired burning appliance to their previous conditions of use.

9 Gas Supply and Piping



WARNING: FIRE OR EXPLOSION HAZARD

- ▶ Never purge a gas line into a combustion chamber. Never test for gas leaks with an open flame. Use a commercially available soap solution made specifically for the detection of leaks to check all connections.



WARNING: FIRE OR EXPLOSION HAZARD

- ▶ Use proper length of pipe to avoid stress on gas control manifold and to prevent a gas leak.



CAUTION: FURNACE OVERHEAT HAZARD

- ▶ Connect gas pipe to gas valve using a backup wrench to avoid damaging gas controls and to avoid burner misalignment.



WARNING: FIRE OR EXPLOSION HAZARD

- ▶ If local codes allow the use of a flexible gas appliance connector, always use a new listed connector. Do not use a connector which has previously served another gas appliance. Black iron pipe shall be installed at the furnace gas control valve and extend a minimum of 2 inches outside the furnace.



Adjusting the minimum supply pressure below the limits in Table 8 could lead to unreliable ignition. Gas input to the burners must not exceed the rated input shown on the rating plate. Overfiring of the furnace can result in premature heat exchanger failure. Gas pressures in excess of 13 in. WC can also cause permanent damage to the gas valve.

At all altitudes and with either fuel (natural gas or LP), the air temperature rise must be within the range listed on the furnace nameplate. Should this appliance be converted to LP, refer to the instructions included in the factory authorized natural gas to LP conversion kit.

9.1 General

The furnace rating plate includes the approved furnace gas input rating and gas types. The furnace must be equipped to operate on the type of gas applied. This includes any conversion kits required for alternate fuels and/or high altitude.

Inlet gas supply pressures must be maintained within the ranges specified in Table 8. The supply pressure must be constant and available with all other household gas-fired appliances operating. The minimum gas supply pressure must be maintained to prevent unreliable ignition. The maximum must not be exceeded to prevent unit overfiring.

	Inlet Gas Supply Pressure	
Natural Gas	Minimum: 5.0 in. WC	Maximum: 10.5 in. WC
Propane Gas	Minimum: 11.0 in. WC	Maximum: 13.0 in. WC

Table 8 Inlet Gas Supply Pressure

9.2 High Altitude Derate

Alternately, in high altitude applications, a standard derate for altitude from National Fuel Gas Code ANSI Z223.1 of 4% per 1000 feet above sea level, may be taken. Refer to the most recent version of ANSI Z223.1 for correct gas orifice based on your specific application. The orifices must be selected using the specifications listed in the table below. The furnace derate is 4% for each 1,000 feet above sea level. Table 9 is based upon a heating value of approximately 1,000 Btu/ft³.

In some areas the gas supplier may artificially derate the gas in an effort to compensate for the effects of altitude. If the gas is artificially derated, the appropriate orifice size must be determined based upon the BTU/ft³ content of the derated gas and the altitude. Refer to the latest version of NFPA54/ANSI Z223.1 and information provided by the gas supplier to determine the proper orifice size.

US installation

Input Rate KBTU/H	Number of burners	Elevation (Ft)		Elevation (Ft)		Elevation (Ft)		Elevation (Ft)		Elevation (Ft)	
		0-2000		2000-4000		4000-6000		6000-8000		8000-10000	
		NG**	LP	NG**	LP	NG**	LP	NG**	LP	NG**	LP
50	3	49	57	50	58	51	59	52	61	53	62
80	5	49	57	50	58	51	59	52	61	53	62
100	6	49	57	50	58	51	59	52	61	53	62
120	7	49	57	50	58	51	59	52	61	53	62

Table 9 High Altitude Derate Orifice Size Chart (Natural and LP Gas*)

*LP orifice based on 10 in. WC manifold pressure

The input to the furnace must be checked AFTER reorificing.

**NG denotes natural gas

9.3 Propane Gas (LP) Conversion



WARNING: FIRE OR EXPLOSION HAZARD

- ▶ Possible property damage personal injury or death may occur if the correct conversion kits are not installed. The appropriate kits must be applied to ensure safe and proper furnace operation. All conversions must be performed by a qualified installer or service agency.

This unit is configured for natural gas, however, all furnaces come standard with a conversion kit for propane gas (LP). The appropriate manufacturer's propane gas conversion kit (Bosch Part: 8-733-951-605), must be applied for propane gas (LP) installations. High altitude installations (above 2000 ft), refer to the "High Altitude Derate" Section for details.

The indicated kits must be used to ensure safe and proper furnace operation. All conversions must be performed by a qualified installer, or service agency. Refer to the installation instructions supplied with the conversion kit.

9.4 Gas Piping Connections

To avoid possible unsatisfactory operation or equipment damage due to underfiring of equipment, use the proper size of natural/propane gas piping needed when running pipe from the meter/tank to the furnace.

When sizing a trunk line, be sure to include all appliances which will operate simultaneously (see Table 10).

The gas piping supplying the furnace must be properly sized based on the gas flow required specific gravity of the gas and length of the run. The gas line installation must comply with local codes or in their absence refer to the latest version of NFPA54/ANSI Z223.1.

Nominal iron pipe size in.	Internal DIA. in.	Length of pipe-ft				
		10	20	30	40	50
1/2	0.622	175	120	97	82	73
3/4	0.824	360	250	200	170	151
1	1.049	680	465	375	320	285
1-1/4	1.380	1400	950	770	660	580
1-1/2	1.610	2100	1460	1180	990	900

Table 10 Natural Gas Capacity of Pipe in Cubic Feet of Gas Per Hour (CFH)

(Pressure 0.5 psig or less and pressure drop of 0.3 in. WC; Based on 0.60 Specific Gravity Gas)

$$CFH = \frac{\text{BTUH Furnace input}}{\text{Heating Value of Gas (BTU/Cubic Foot)}}$$

To connect the furnace to the building's gas piping, the installer must supply a ground joint union, drip leg, manual shutoff valve and line and fittings to connect to gas valve. In some cases, the installer may also need to supply a transition piece from 1/2" pipe to a larger pipe size.

The following stipulations apply when connecting gas piping.

- ▶ Use pipe joint compound on male threads only. Pipe joint compound must be resistant to the action of the fuel used.
- ▶ Use ground joint unions.
- ▶ Install a drip leg to trap dirt and moisture before it can enter the gas valve. The drip leg must be a minimum of three inches long.
- ▶ Install a 1/8" NPT pipe plug fitting, accessible for test gage connection immediately upstream of the gas supply connection to the furnace.
- ▶ Use two pipe wrenches when making connection to the gas valve to keep it from turning. The orientation of the gas valve on the manifold must be maintained as shipped from the factory.
- ▶ Install a manual shutoff valve between the gas meter and unit within six feet of the unit. If a union is installed, the union must be downstream of the manual shutoff valve, between the shutoff valve and the furnace.
- ▶ Tighten all joints securely.
- ▶ Connect the furnace to the building piping by one of the following methods:
 1. Rigid metallic pipe and fittings.
 2. Semi-rigid metallic tubing and metallic fittings. Aluminum alloy tubing must not be used in exterior locations.
 3. Use listed gas appliance connectors in accordance with their instructions. Connectors must be fully in the same room as the furnace.
 4. The installation of piping shall be in accordance with piping codes and the regulations of the local gas company. Pipe joint compound must be resistant to the chemical reaction with liquefied petroleum gases.

When the gas piping enters through the right side of the furnace the installer must supply the following fittings (starting from the gas valve):

- ▶ 90 degree elbows (2).
- ▶ Close nipple.
- ▶ Straight pipe to reach the exterior of the furnace.

A ground joint union, drip leg, and manual shutoff valve must also be supplied by the installer. In some cases, the installer may also need to supply a transition piece from 1/2" to another pipe size.

When the gas piping enters through the left side of the furnace the installer must supply the following fittings (starting from the gas valve):

- ▶ Straight pipe to reach the exterior of the furnace.
- ▶ A ground joint union, drip leg, and manual shutoff valve must also be supplied by the installer. In some cases, the installer may also need to supply a transition piece from 1/2 inch to another pipe size.

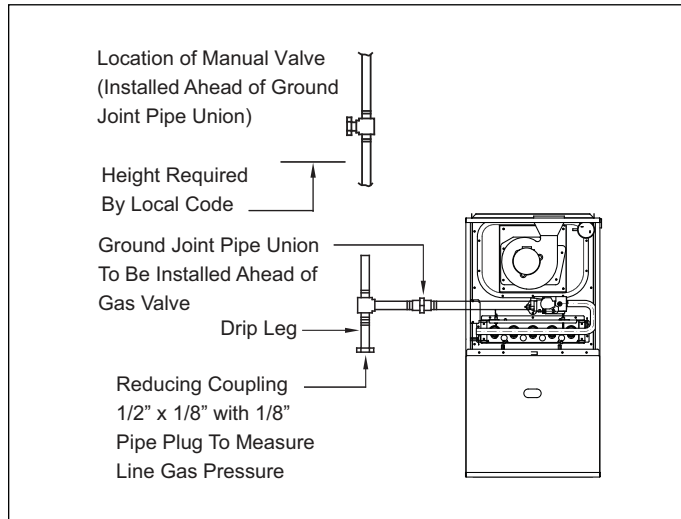

Figure 24 Typical gas pipe arrangement

9.5 Gas Piping Checks

Before placing unit in operation, leak test the unit and gas connections.



WARNING: FIRE OR EXPLOSION HAZARD

- ▶ Never test for gas leaks with an open flame. Use a commercially available soap solution made specifically for the detection of leaks to check all connections.

Check for leaks using an approved chloride-free soap and water solution, an electronic combustible gas detector or other approved testing methods.



Never exceed specified pressures for testing. Higher pressures may damage the gas valve and cause subsequent overfiring resulting in heat exchanger failure.

This furnace must be isolated from the gas supply system by closing its manual shutoff valve before pressure testing of gas supply piping system with test pressures equal to or less than 1/2 psig (3.48 kPa).

10 Electrical Connections



WARNING: ELECTRICAL SHOCK HAZARD

- ▶ Blower access panel door switch opens 115V power to control. No component operation can occur. Do not bypass or close the blower access panel door switch with panel removed.

See Fig. 27, (page 30) for field wiring diagram showing typical field 115V wiring. Check all factory and field electrical connections for tightness. Field-supplied wiring shall conform with the limitations of 63°F (35°C) rise.



WARNING: ELECTRICAL SHOCK AND FIRE HAZARD

- ▶ The cabinet MUST have an uninterrupted or unbroken ground according to NEC ANSI/NFPA 70-latest edition or local codes to minimize personal injury if an electrical fault should occur.
This may consist of electrical wire, conduit approved for electrical ground or a listed, grounded power cord (where permitted by local code) when installed in accordance with existing electrical codes. Refer to the power cord manufacturer's ratings for proper wire gauge. Do not use gas piping as an electrical ground.



CAUTION: FURNACE MAY NOT OPERATE

- ▶ Furnace control must be grounded for proper operation or else control will lock out. Control must remain grounded through green/yellow wire routed to gas valve and manifold bracket screw.

10.1 115V Wiring

Verify that the voltage, frequency, and phase correspond to that specified on unit rating plate. Also, check to be sure that service provided by utility is sufficient to handle load imposed by this equipment. Refer to rating plate or Table 11 (page 29) for equipment electrical specifications.

Make all electrical connections in accordance with National Electrical Code (NEC) ANSI/NFPA 70-latest edition and any local codes or ordinances that might apply.



WARNING: FIRE HAZARD

- ▶ Do not connect aluminum wire between disconnect switch and furnace. Use only copper wire.

Use a separate, fused branch electrical circuit with a properly sized fuse or circuit breaker for this furnace. See Table 11 for wire size and fuse specifications. A readily accessible means of electrical disconnect must be located within sight of the furnace.



Proper polarity must be maintained for 115V wiring. If polarity is incorrect, control LED status indicator light will flash rapidly and furnace will NOT operate.

Junction box relocation



If factory location of J-Box is acceptable, go to next section **Electrical Connection to J-box.**



On 14" wide cabinet models, the J-Box shall not be relocated to other side of furnace cabinet when the vent pipe is routed within the cabinet.

1. Remove and save two screws holding J-Box (See Figure 25).



The J-Box cover need not be removed from the J-Box in order to move the J-Box. Do NOT remove green ground screw inside J-Box. The ground screw is not threaded into the cabinet flange and can be lifted out of the clearance hole in cabinet while swinging the front edge of the J-Box cover away from the cabinet.

2. Move J-Box to desired location.
3. Fasten J-Box to cabinet with two screws removed in Step 1.
4. Route J-Box wires within furnace away from sharp edges, rotating parts and hot surfaces.

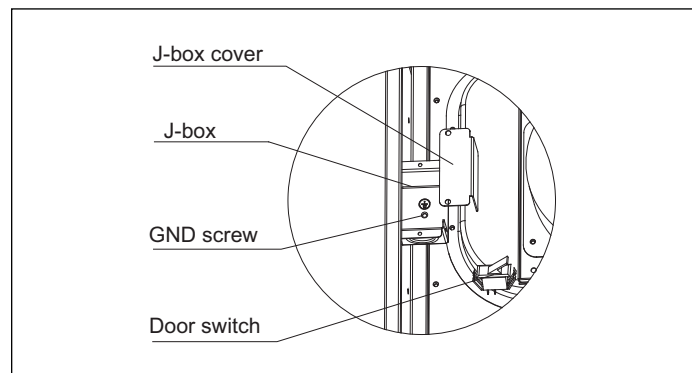

Figure 25 J-box

10.2 Electrical Connection to J-Box

Field-Supplied Electrical Box on Furnace J-Box Bracket

See Fig. 24 on previous page.

1. Remove cover from furnace J-Box.
2. Attach electrical box to furnace J-Box bracket with at least two field-supplied screws through holes in electrical box into holes in bracket. Use blunt-nose screws that will not pierce wire insulation.
3. Route furnace power wires through holes in electrical box and J-Box bracket, and make field-wire connections in electrical box. Use best practices (NEC in U.S.) for wire bushings, strain relief, etc.
4. Route and secure field ground wire to green ground screw on J-Box bracket, OR FURNACE WILL FAIL TO OPERATE.
5. Connect line voltage leads as shown in Fig. 27.
6. Reinstall cover to J-Box. Do not pinch wires between cover and bracket.

Electrical Box on Furnace Cabinet Side.

See Fig. 25 and Fig 27.



WARNING: FIRE OR ELECTRICAL SHOCK HAZARD

- ▶ If field-supplied manual disconnect switch is to be mounted on furnace cabinet side, select a location where a drill or fastener cannot damage electrical or gas components.

1. Select and remove a knockout hole in the cabinet where the electrical box is to be installed.



Check that duct on side of furnace will not interfere with installed electrical box.

2. Remove the desired electrical box hole knockout and position the hole in the electrical box over the hole in the furnace cabinet.
3. Fasten the electrical box to cabinet by driving two field-supplied screws from inside electrical box into cabinet steel.
4. Remove and save two screws holding J-Box. (See Fig. 25.)
5. Pull furnace power wires out of 1/2-inch diameter hole in J-Box. Do not loosen wires from strain-relief wire-tie on outside of J-Box.
6. Route furnace power wires through holes in cabinet and into electrical box.
7. Pull field power wires into electrical box.
8. Remove cover from furnace J-Box.
9. Route field ground wire through holes in electrical box and cabinet, and into furnace J-Box.
10. Reattach furnace J-Box to furnace cabinet with screws removed in Step 4.
11. Secure field ground wire to green ground screw on J-Box Bracket.
12. Complete electrical box wiring and installation. Connect line voltage leads as shown in Fig. 27. Use best practices (NEC in U.S.) for wire bushings, strain relief, etc.
13. Reinstall cover to J-Box. Do not pinch wires between cover and bracket.

10.3 Power Cord Installation in Furnace J-box



Power cords must be able to handle the electrical requirements listed in Table 11. Refer to power cord manufacturer's listings.

1. Remove cover from J-Box.
2. Route listed power cord through 7/8-inch diameter hole in J-Box.
3. Secure power cord to J-Box bracket with a strain relief bushing or a connector approved for the type of cord used.
4. Secure field ground wire to green ground screw on J-Box bracket.
5. Connect line voltage leads as shown in Fig. 27.
6. Reinstall cover to J-Box. Do not pinch wires between cover and bracket.

10.4 BX Cable Installation in Furnace J-box

1. Remove cover from J-Box.
2. Route BX cable into 7/8-inch diameter hole in J-Box.
3. Secure BX cable to J-Box bracket with connectors approved for the type of cable used.
4. Secure field ground wire to green ground screw on J-Box bracket.
5. Connect line voltage leads as shown in Fig. 27.
6. Reinstall cover to J-Box. Do not pinch wires between cover and bracket.

10.5 24-V Wiring

Make field 24V connections at the 24V terminal strip (See Fig. 27.). Connect terminal Y as shown in Fig. 27 for proper cooling operation. Use only 18 AWG, color-coded, copper thermostat wire.

The 24V circuit contains an automotive-type, 3-Amp. fuse located on the control. Any direct shorts during installation, service, or maintenance could cause this fuse to blow. If fuse replacement is required, use ONLY a 3-Amp. fuse of identical size.

10.6 Accessories (Field Supplied)

1. Electronic Air Cleaner (EAC)

For connection to an Electronic Air Cleaner (if needed), use ¼-inch female quick connect terminals to engage with the two ¼-inch male quick connect terminals on the control board marked EAC-H and EAC-N. The terminals are rated for 115 VAC, 1.0 amps maximum and are energized when blower motor is in operation (see Figure 26).

2. Humidifier (HUM)

Connect an accessory 24 VAC 0.5 Amp. maximum humidifier using the ¼-inch male quick connect terminals marked HUM-H and HUM-N, respectively, on the control board. The HUM is energized when gas valve relay is energized (see Figure 26)

10.7 Grounding

The furnace must be electrically grounded in accordance with local codes or, in the absence of local codes, with the National Electrical Code, ANSI/NFPA 70, if an external electrical source is utilized.

Input		Output		Nominal Airflow CFM	MAX. Unit Amps	AFUE	Air Temp. Rise		Max. Over-Current Protection Amps	Min. Wire Size (AWG) @ 75 ft	Max. Outlet Air Temp	
MBH	kW	MBH	kW				°F	°C			°F	°C
50A	14.7	40	11.8	1200	7.1	80	25-55	14-31	15	14	155	68
80B	23.4	64	18.7	1600	8.5	80	30-60	17-33	15	14	160	71
100C	29.3	80	23.4	2000	9.7	80	30-60	17-33	15	14	160	71
120D	35.2	96	28.1	2000	10.1	80	35-65	19-36	15	14	165	74

Table 11 Ratings & Physical / Electrical Data

Annual Fuel Utilization Efficiency (AFUE) numbers are determined in accordance with DOE Test procedures.

National Electrical Code (NFPA-70-latest edition) and all local codes.

The furnace shall be installed so that the electrical components are protected from water.

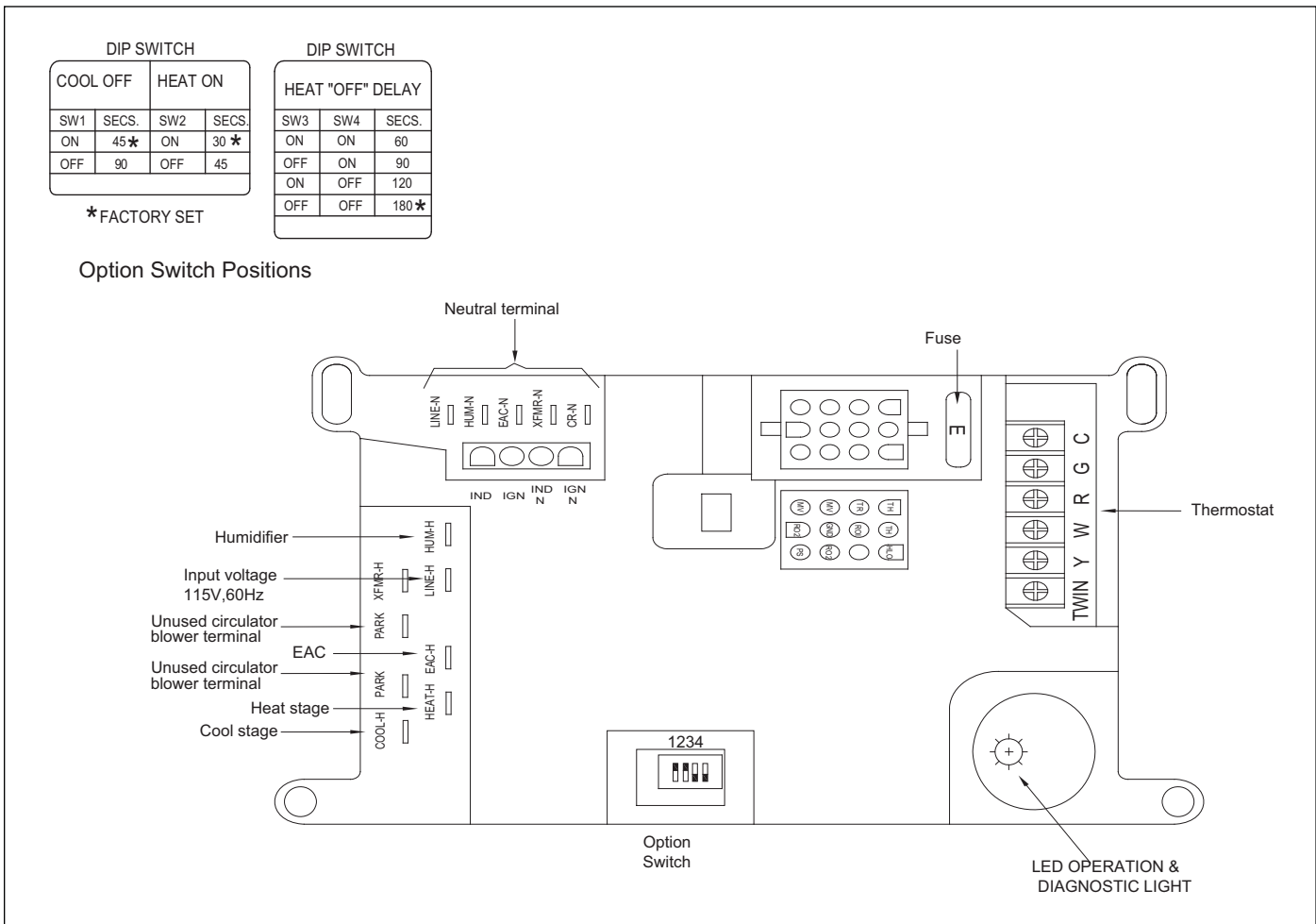

Figure 26 Furnace control

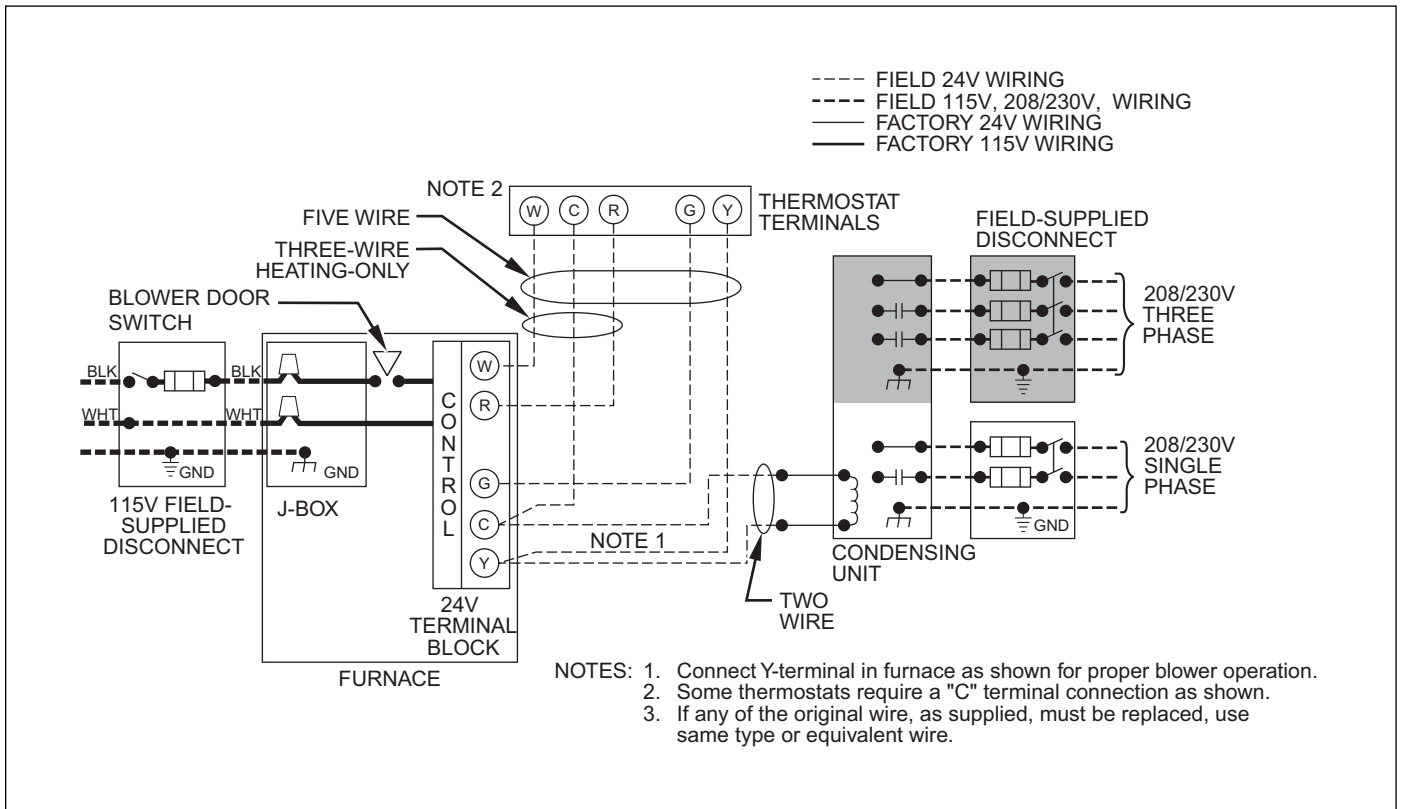

Figure 27 Heating and Cooling Application Wiring Diagram with I-Stage Thermostat

11 Start-Up, Adjustment, and Safety Check

11.1 General



WARNING: FIRE HAZARD

- ▶ This furnace is equipped with manual reset limit switches in the gas control area. The switches open and shut off power to the gas valve if a flame rollout or overheating condition occurs in the gas control area. DO NOT bypass the switches. Correct inadequate combustion air supply problem before resetting the switches.



CAUTION: CUT HAZARD

- ▶ Sheet metal parts may have sharp edges or burrs. Use care and wear appropriate protective clothing, safety glasses, and gloves when handling parts and servicing furnaces.

1. Maintain 115V wiring and ground. Improper polarity will result in rapid flashing LED and no furnace operation (See Fig. 27).
2. Make thermostat wire connections at the 24-V terminal block on the furnace control. Failure to make proper connections will result in improper operation (See Fig. 27).
3. Gas supply pressure to the furnace must follow Table 8 "Inlet Gas Supply Pressure" in Section 9.1.
4. Check all manual-reset switches for continuity.
5. Install blower and burner access panels. Panels must be in place to operate furnace.

11.2 Start-Up Procedures



WARNING: FIRE AND EXPLOSION HAZARD

- ▶ Never test for gas leaks with an open flame. Use a commercially available soap solution made specifically for the detection of leaks to check all connections.

1. Purge gas lines after all connections have been made.
2. Check gas lines for leaks.



WARNING: ELECTRICAL SHOCK HAZARD

- ▶ Blower access panel switch opens 115V power to control. No component operation can occur unless the switch is closed. Caution must be taken when manually closing this switch for service purposes.

3. This furnace is also equipped with a self-diagnosing electronic control module. In the event a furnace component is not operating properly the control module LED will flash on and off in a factory programmed sequence depending on the problem encountered. This light can be viewed through the observation window in the blower access panel. Refer to the Troubleshooting Chart on pages 37-39 for further explanation of the lighting codes. Follow the start-up and adjustment items in Section 11. Refer to Section 12 for further information on Operational Checks.

11.3 Furnace Start-Up

1. Close the manual gas shutoff valve external to the furnace.
2. Turn off the electrical power to the furnace.
3. Set the room thermostat to the lowest possible setting.
4. Remove the burner access panel.



WARNING:

- ▶ This furnace is equipped with an ignition device which automatically lights the burner. Do not try to light the burner by hand.

5. Push the gas valve switch to the OFF position.
6. Wait five minutes to clear out any gas. Then smell for gas including near the floor.
7. If gas can be smelled following the five minute waiting period, repeat step 6. If you have waited more than 10 minutes and still smell gas, check for leaks using a soap and water solution.
8. If you do not smell gas after five minutes, push the gas valve switch to the ON position.



WARNING: FIRE AND EXPLOSION HAZARD

- ▶ Never test for gas leaks with an open flame. Use a commercially available soap solution made specifically for the detection of leaks to check all connections.

9. Replace the burner access panel on the front of the furnace.
10. Open the manual gas valve external to the furnace.
11. Turn on the electrical power supply to the furnace.
12. Set the room thermostat to slightly above room temperature. After some delay, the furnace will start.
13. Refer to Section 11.4 "Sequence of Operation" for specific details on how the furnace operates.



There is an approximate 48 second delay between thermostat energizing and burner firing.

Furnace shutdown

In case of furnace malfunction, use the following steps to shut the unit down:

1. Set the thermostat to OFF or it's lowest temperature setting.
2. Turn off the electrical power supply to the furnace.
3. Remove the burner access panel.
4. Close manual gas shutoff valve external to the furnace.
5. Push the gas valve switch to the OFF position.
6. Replace burner access panel.

11.4 Sequence of Operation



Furnace control must be grounded for proper operation or control will lock out. Control is grounded through green wire routed to gas valve and manifold bracket screw. Follow the sequence of operation through the heating, cooling, and fan only modes.

Read and follow the wiring diagram (Fig. 27) very carefully.

The blower access panel must be installed for power to be conducted through all electrical components.

1. Heating mode

(See Fig. 26 for thermostat connections.)

The wall thermostat "calls for heat," closing the R-to-W circuit. The furnace control performs a self-check, verifies if the pressure switch contacts are open, and starts the inducer motor.

- a. Inducer Prepurge Period: The inducer blower and optional humidifier are energized within one second. The pressure switch contacts close to begin a 30 second prepurge period.
- b. Igniter Warm-Up: At the end of the prepurge period, the hot-surface igniter is energized for a 17 second igniter warm-up period.

This controller has an adaptive algorithm that adjusts the duration of the igniter warm-up, to extend igniter life. Upon initial application of power, the warm-up time is 17 seconds. The igniter on-time will then be increased or decreased depending on whether or not a flame is achieved. The warm-up time is limited to a maximum of 21 seconds. During the first 64 warm-up periods following power-up, the warm-up time may not be less than 17 seconds.

Upon a call for heat, if the warm-up time has not been locked, it will be decreased by one second. This reduction of the igniter on-time will continue until a flame fails to be achieved (resulting in a retry).

In the event of a retry, the warm-up time will be increased by two seconds and locked in at that duration. Once the warm-up time is locked, it remains fixed until another call for heat results in a retry, in which case the warm-up time is again increased by two seconds and remains locked.

In the event of two successive retry attempts, the warm-up time will be unlocked and set to 21 seconds. If flame is then achieved, the warm-up time will begin adapting again with the next call for heat. If, however, this third attempt fails to achieve flame, the control will go into system lock out.

- c. Trial-for-Ignition Sequence: When the igniter warm-up period is completed, the main gas valve relay contacts energize the gas valve, the gas valve opens for 4 seconds. The gas valve permits gas flow to the burners where it is ignited by the igniter. A 4 second flame proving period begins.
- d. Flame-Proving: When the burner flame is proved by the flame sensor, the furnace control continues to hold the gas valve open.

If flame is not detected, the gas valve is de-energized, the igniter is turned off, and the furnace control goes into the "retry" sequence. The "retry" sequence provides a 60-second wait following an unsuccessful ignition attempt (a flame not detected). After this wait, the ignition sequence is restarted with an additional 2 seconds of igniter warm-up time. If this ignition attempt is unsuccessful, one more retry will be made before the control goes into system lock out.

If flame is detected, then lost, the furnace control will repeat the initial ignition sequence for a total of four "recycles". After four unsuccessful "recycle" attempts, the control will go into system lockout.

If flame is established for more than 10 seconds after ignition, the furnace controller will clear the ignition attempt (or retry) counter. If flame is lost after 10 seconds, it will restart the ignition sequence. This can occur a maximum of four times before system lock out.

- e. Blower-On Delay: If the burner flame is proven, the blower motor is energized on HEAT-H speed 30 seconds after the gas valve is energized. Simultaneously, the electronic air cleaner (field supplied) terminal is energized and remains as such as long as the blower motor is energized.
- f. Blower-Off Delay: When the thermostat is satisfied, the R-to-W circuit is opened, de-energizing the gas valve, stopping gas flow to the burners, the inducer motor will remain energized for a 15 second post-purge period. Humidifier (field supplied) is de-energized. The blower motor and air cleaner terminal will remain energized for 60, 90, 120, or 180 seconds (depending on the HEAT-OFF delay selection). The furnace control CPU is factory-set for a 180 second HEAT-OFF delay.

Timing specifications

(All times are in seconds, unless noted otherwise)

PRE-PURGE	30
INITIAL IGNITOR WARM-UP	17
MINIMUM IGNITOR WARM- UP	5
MAXIMUM IGNITOR WARM- UP	21
IGNITION ACTIVATION PERIOD	1
TRIAL FOR IGNITION PERIOD	4
RETRIES	2 times
VALVE SEQUENCE PERIOD	12
INTERPURGE	60
POST-PURGE	15
LOCKOUT TIME	300
HEAT DELAY-TO-FAN-ON*	30, 45
HEAT DELAY-TO-FAN-OFF*	60/90/120/180
COOL DELAY-TO-FAN-ON	5
COOL DELAY-TO-FAN-OFF*	45, 90
AUTO RESET (see page 36)	60 minutes
HUMIDIFIER (optional)	YES
ELECTRONIC AIR CLEANER (optional)	YES

Table 12

* These times will vary depending on option switch position. The control is factory-set at 30 seconds heat delay-to-fan-on, 180 seconds heat delay-to-fan-off and 45 seconds cool delay-to-fan-off. See Fig. 30 for further information.

2. Cooling Mode (if applicable)

The thermostat “calls for cooling.”

(See Fig. 26 for thermostat connections)

The thermostat closes the R-to-G-and-Y circuits. The R-to-Y circuit starts the outdoor unit, and the R-to-G-and-Y circuits start the furnace blower motor on COOL-H speed. The cool delay-to-fan-on period begins. After the delay period ends, the optional electronic air cleaner is energized, and the circulator fan is energized at cool speed (which is factory set to HIGH). After the thermostat is satisfied, the compressor is de-energized and the cool mode delay-to-fan-off period begins. After the delay-to-fan-off period ends, the circulator fan and electronic air cleaner (optional) are de-energized.

3. FAN Mode

When the R-to-G circuit is closed by the thermostat, the blower motor will operate on COOL-H speed. If the thermostat fan mode is set to ON, the circulator fan (cool speed) and optional electronic air cleaner are energized. When the fan mode is returned to AUTO, the circulator fan and electronic air cleaner (optional) are de-energized.

11.5 Gas Manifold Pressure Measurement and Adjustment



CAUTION:

- ▶ To prevent unreliable operation or equipment damage, the gas manifold pressure must be as specified on the unit rating plate. Only minor adjustments should be made by adjusting the gas valve pressure regulator.

This valve is shipped from the factory with the regulator preset to 3.5 in. WC. Consult the appliance rating plate to ensure burner manifold pressure is as specified. If another outlet pressure is required, follow these steps (see Table 13 and Fig. 28).

1. Turn OFF all electrical power to the system.
2. Using a 3/32 inch hex wrench, loosen outlet pressure tap screw one turn. Do not remove screw.
3. Attach a hose and manometer to the outlet pressure barb fitting of valve to over lap at least 3/8”
4. Turn ON system power and set thermostat to a call for heat.
5. Using a leak detection solution or non-chlorine soap suds check for leaks at hose connection. Bubbles forming indicate a leak. SHUT OFF GAS AND FIX ALL LEAKS IMMEDIATELY!
6. Remove burner access panel.
7. Remove regulator screw cover. Turn regulator screw either clockwise to increase pressure or counter clockwise to decrease. Always adjust regulator to provide the correct pressure according to the original equipment manufacturer specifications listed on the appliance rating plate.
8. Replace regulator screw cover and finger-tighten securely.
9. Turn OFF all electrical power to the system.
10. Remove manometer and hose from outlet pressure tap.
11. Tighten outlet pressure tap clockwise 7 in-lbs minimum to seal port.
12. Replace burner access panel.
13. Turn ON system power and set thermostat to call for heat.

14. Using a leak detection solution or non-chlorine soap suds, check for leaks at hose connection. Bubbles forming indicate a leak. SHUT OFF GAS AND FIX ALL LEAKS IMMEDIATELY!

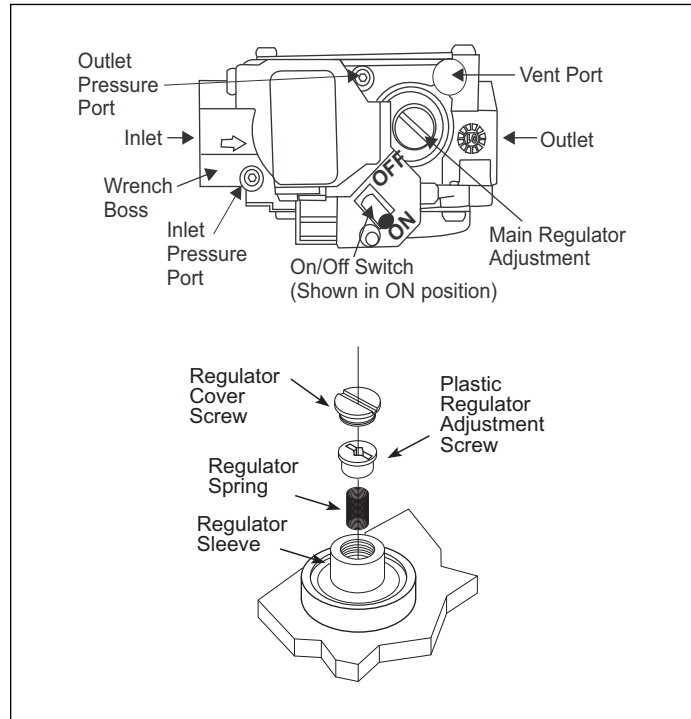

Figure 28 Gas valve and regulator adjustment

15. Measure gas manifold pressure with burners firing. Adjust manifold pressure per the Manifold Gas Pressure table.

Input Rating KBTU/H	Manifold Gas Pressure Range	
	Natural Gas	Propane Gas
50	4.3-4.7 in. WC	9.7-10.3 in. WC
80	3.6-4.0 in. WC	9.7-10.3 in. WC
100	4.0-4.4 in. WC	9.7-10.3 in. WC
120	4.3-4.7 in. WC	9.7-10.3 in. WC

Table 13 Manifold Gas Pressure

The final manifold pressure must not vary more than ± 0.3 in. WC from specified manifold pressure.

Any necessary major changes in gas flow rate should be made by changing the size of the burner orifice.

11.6 Gas Input Rate Measurement (Natural Gas Only)

The gas input rate to the furnace must never be greater than that specified on the unit rating plate. To measure natural gas input using the gas meter, use the following procedure.

1. Turn OFF the gas supply to all other gas-burning appliances except the furnace.
2. While the furnace is operating, time and record one complete revolution of the smallest gas meter dial.
3. Calculate the number of seconds per cubic foot (sec/ft³) of gas being delivered to the furnace. If the dial is a one cubic foot dial, divide the number of seconds recorded in step 2 by one. If the dial is a two cubic foot dial, divide the number of seconds recorded in step 2 by two.
4. Calculate the furnace input in BTUs per hour (BTU/hr). Input equals the installation's gas heating value multiplied by a conversion factor (hours to seconds) divided by the number of seconds per cubic foot. The measured input must not be greater than the input indicated on the unit rating plate.

Example:

Installation's gas heating (HTG) value: 1,000 BTU/ft³ (Obtained from gas supplier)

Installation's seconds per cubic foot: 34 sec/ft³

Conversion Factor (hours to seconds): 3600 sec/hr

Input = (Htg. value x 3600) ÷ seconds per cubic foot

Input = (1,000 BTU/ft³ x 3600 sec/hr) ÷ 34 sec/ft³

Input = 106,000 BTU/hr

This measured input must not be greater than the input indicated on the unit rating plate.

5. Turn ON gas and relight appliances turned off in step 1. Ensure all the appliances are functioning properly and that all pilot burners are operating.

11.7 Temperature Rise Adjustment

Air temperature rise is the temperature difference between supply and return air. The proper amount of temperature rise is usually obtained when the unit is operated at the rated input with the "as shipped" blower speed. If the correct amount of temperature rise is not obtained, it may be necessary to change the blower speed.



CAUTION:

- ▶ An incorrect temperature rise can cause condensing in or overheating of the heat exchanger. Determine and adjust the temperature rise as follows. The temperature rise must be within the range specified on the rating plate.

Temperature Rise Adjustment

1. Operate furnace with burners firing for approximately 15 minutes. Ensure all registers are open and all duct dampers are in their final (fully or partially open) position.
2. Place thermometers in the return and supply ducts as close to the furnace as possible. Thermometers must not be influenced by radiant heat by being able to "see" the heat exchanger (see Fig. 28).
3. Subtract the return air temperature from the supply air temperature to determine the air temperature rise. Allow adequate time for thermometer readings to stabilize.

4. Adjust temperature rise by adjusting the circulator blower speed. Increase blower speed to reduce temperature rise. Decrease blower speed to increase temperature rise. Refer to the following section for speed changing details.

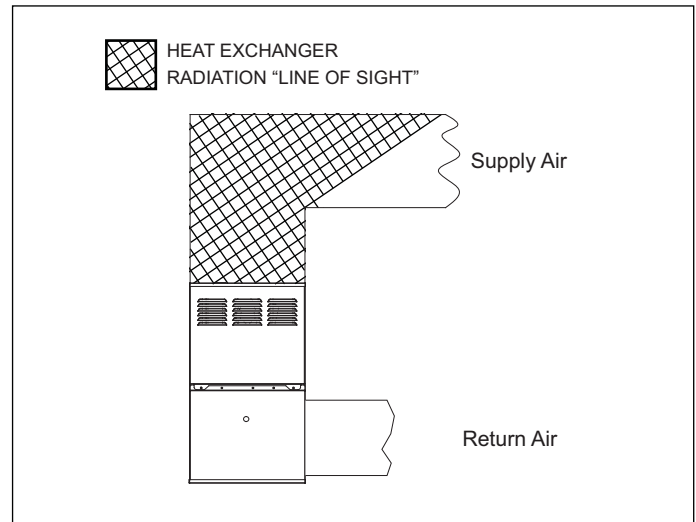

Figure 29 Temperature rise measurement

11.8 Circulator Blower Speed Adjustment



WARNING: ELECTRICAL SHOCK HAZARD

- ▶ Turn OFF power to the furnace before changing speed taps.

This furnace is equipped with a PSC circulator blower motor. This blower provides ease in adjusting blower speeds. The cooling blower speed factory setting is always set to HIGH speed. The heating blower speed is factory set depending on the model. The BGS80M050A3A model is factory set to MEDIUM-LOW speed. All other models are factory set to MEDIUM-HIGH speed. These blower speeds should be adjusted by the installer to match the installation requirements so as to provide the correct heating temperature rise and the correct cooling CFM.

Refer to Table 4, (page 19) - Air Delivery - CFM (Without Filter)*

To adjust the circulator blower speed proceed as follows:

1. Turn OFF power to the furnace.
2. Select the heating and cooling blower speeds that match the installation requirements from the **Table 4 - Air Delivery - CFM (Without Filter)***
3. Relocate desired motor leads to the circulator blower heat and cool speed terminals on the integrated control module. (Terminals are identified as HEAT-H and COOL-H). If heating and cooling blower speeds are the same a jumper wire must be used between the heat and cool terminals.
4. Connect all unused blower motor leads to the "PARK" terminals on the integrated control module. Any leads not connected to the "PARK" terminals must be taped.
5. Turn ON power to furnace.
6. Verify proper temperature rise as outlined in Temperature Rise section.



Items in this section refer to the air circulator blower fan NOT to the induced draft blower. The induced draft blower timing sequence is not adjustable, only the circulator blower fan timing is adjustable.

As shipped, the circulator blower fan will remain on for 180 seconds after the gas valve closes. When a call for cooling occurs the circulator fan comes on and remains on for 45 seconds after the call for cooling ends. During normal heating operation, the circulator fan will come on approximately 30 seconds after the gas valve opens.

DIP SWITCH				DIP SWITCH		
COOL OFF		HEAT ON		HEAT "OFF" DELAY		
SW1	SECS.	SW2	SECS.	SW3	SW4	SECS.
ON	45*	ON	30*	ON	ON	60
OFF	90	OFF	45	OFF	ON	90
				ON	OFF	120
				OFF	OFF	180*

*FACTORY DEFAULT

Figure 30 Adjustment switches

12 Operational Checks



WARNING: FIRE, EXPLOSION, ELECTRICAL SHOCK, AND CARBON MONOXIDE POISONING HAZARD

- To avoid personal injury or death. Do not remove any internal component covers or attempt any adjustment. Electrical compartments are contained in both compartments. Contact a qualified service agent at once if an abnormal flame appearance should develop.

Burner Flame

The burner flames should be inspected with the burner access panel installed. Flames should be stable, quiet, soft, and blue (dust may cause orange tips but they must not be yellow). Flames should extend directly outward from the burners without curling, floating, or lifting off, and should enter heat-exchanger tube. Flames must not impinge on the sides of the heat exchanger firing tubes.

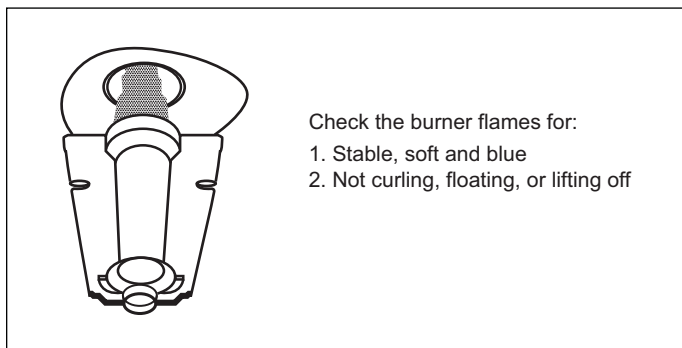

Figure 31 Burner Flame

13 Safety Circuit Description

13.1 General

A number of safety circuits are employed to ensure safe and proper furnace operation. These circuits serve to control any potential safety hazards and serve as inputs in the monitoring and diagnosis of abnormal function. These circuits are continuously monitored during furnace operation by the integrated control module.

13.2 Integrated Control Module

The integrated control module is an electronic device which controls all furnace operations. Responding to the thermostat, the module initiates and controls normal furnace operation, and monitors and addresses all safety circuits. If a potential safety concern is detected, the module will take the necessary precautions and provide diagnostic information through an LED.

13.3 Chamber Limit Switch - Fixed

The chamber limit switch - fixed control is located on the partition panel and monitors heat exchanger compartment temperature (it is an automatic reset temperature sensor). The limit guards against the overheating resulting from insufficient air passing over the heat exchanger.

13.4 Fan Mounted Limit Switch

The fan mounted limit switch is located on the air circulating blower housing. It is an automatic reset temperature sensor. Reverse flow switch shuts off the furnace when air circulating blower fails on downflow or horizontal installations to prevent air filter or other parts from overheating by hot air.

13.5 Rollout Switch - Resettable

The rollout switch - resettable controls are mounted on the burner/manifold assembly and monitor the burner flame. They are manual-reset temperature sensors. This limit guards against burner flames not being properly drawn into the heat exchanger.

13.6 Pressure Switches

The pressure switches are normally open, negative air pressure activated switches. They monitor the airflow (combustion air and flue products) through the heat exchanger via pressure taps located on the induced draft blower. These switches guard against insufficient airflow (combustion air and flue products) through the heat exchanger.

13.7 Flame Sensor

The flame sensor is a probe mounted to the burner/manifold assembly which uses the principle of flame rectification to determine the presence or absence of flame.



WARNING: FIRE, EXPLOSION, OR CARBON MONOXIDE POISONING HAZARD

- Replace ONLY with the same model number or as specified by the manufacturer.

14 Troubleshooting

14.1 Electrostatic Discharge (ESD) Precautions



Discharge body's static electricity before touching unit. An electrostatic discharge can adversely affect electrical components.

Use the following precautions during furnace installation and servicing to protect the integrated control module from damage. By putting the furnace control and the person at the same electrostatic potential these steps will help avoid exposing the integrated control module to electrostatic discharge. This procedure is applicable to both installed and uninstalled (ungrounded) furnaces.

1. Disconnect all power to the furnace. Do not touch the integrated control module or any wire connected to the control prior to discharging your body's electrostatic charge to ground.
2. Firmly touch a clean unpainted metal surface of the furnace away from the control. Any tools held in a person's hand during grounding will be discharged.
3. Service integrated control module or connecting wiring following the discharge process in step 2. Use caution not to recharge your body with static electricity; (i.e. do not move or shuffle your feet do not touch ungrounded objects etc.). If you come in contact with an ungrounded object repeat step 2 before touching control or wires.
4. Discharge your body to ground before removing a new control from its container. Follow steps 1 through 3 if installing the control on a furnace. Return any old or new controls to their containers before touching any ungrounded object.

14.2 Troubleshooting Chart

Refer to the troubleshooting chart on the following pages for assistance in determining the source of unit operational problems. The red diagnostic LED blinks to assist in troubleshooting the unit. The number of blinks refers to a specific code (See Tables 14-16).

14.3 Resetting From Lockout

Furnace lockout results when a furnace is unable to achieve ignition after three attempts. It is characterized by a non-functioning furnace and a one flash diagnostic LED code from the red LED. If the furnace is in "lockout" it will (or can be) reset in any of the following ways.

1. Automatic reset. The integrated control module will automatically reset itself and attempt to resume normal operations following a one hour lockout period.
2. Manual power interruption. Interrupt 115 volt power to the furnace for 1 - 20 seconds.
3. Manual thermostat cycle. Lower the thermostat so that there is no longer a call for heat for 1 - 20 sec.



If the condition which originally caused the lockout still exists, the control will return to lockout. Refer to the Troubleshooting Chart (Table 14-16) on the following page for aid in determining the cause.



WARNING: FIRE,EXPLOSION AND ASPHYXIATION HAZARD

- ▶ Installation and service must be performed by a qualified service agency or the gas supplier.

Troubleshooting chart

Symptoms of Abnormal Operation	Associated LED	Fault Description(s)	Possible Reason	Corrective Action	Cautions And Notes
<ul style="list-style-type: none"> — Furnace fails to operate — Integrated control module diagnostic LED provides NO SIGNAL 	NONE	<ul style="list-style-type: none"> — No 115 volt power to furnace, or no 24 volt power to integrated control module — Blown fuse or circuit breaker — Integrated control module has an internal fault 	<ul style="list-style-type: none"> — Door switch open, or 24 volt wires improperly connected or loose. — Blown fuse or circuit breaker — Integrated control module has an internal fault. 	<ul style="list-style-type: none"> — Assure 115 and 24 volt power to furnace integrated control module. — Check integrated control module fuse (3A). Replace if necessary. — Check for possible shorts in 115 and 24 volt circuits. Repair as necessary. — Replace bad integrated control module. 	<ul style="list-style-type: none"> — Turn power OFF prior to repair. — Replace integrated control module fuse with 3A automotive fuse. — Read precautions in Electrostatic Discharge section of manual.
<ul style="list-style-type: none"> — Furnace fails to operate — Integrated control module diagnostic LED is flashing ONE (1) flash. 	1 FLASH	<ul style="list-style-type: none"> — Furnace lockout due to an excessive number of ignition attempts. 	<ul style="list-style-type: none"> — Failure to establish flame. Cause may be no gas to burners bad igniter or igniter alignment improper orifices, or coated/ oxidized or improperly connected flame sensor. — Loss of flame after establishment. Cause may be interrupted gas supply or lazy burner flames (improper gas pressure or restriction in flue. 	<ul style="list-style-type: none"> — Locate and correct gas interruption. — Replace or realign igniter. — Check flue piping for blockage proper length elbows and termination. — Verify proper induced draft blower performance. 	<ul style="list-style-type: none"> — Turn power OFF prior to repair. — Igniter is fragile handle with care. — Clean flame sensor with steel wool.
<ul style="list-style-type: none"> — Furnace fails to operate — Integrated control module diagnostic LED is flashing TWO (2) flashes 	2 FLASHES	<ul style="list-style-type: none"> — Pressure switch circuit is closed. — Induced draft blower is not operating. 	<ul style="list-style-type: none"> — Induced draft blower pressure switch contacts sticking. — Shorts in pressure switch circuit. 	<ul style="list-style-type: none"> — Replace induced draft blower pressure switch. — Repair short. 	<ul style="list-style-type: none"> — Turn power OFF prior to repair. — Replace pressure switch with proper replacement part.
<ul style="list-style-type: none"> — Induced draft blower runs continuously with no further furnace operation. — Integrated control module diagnostic LED is flashing THREE (3) flashes. 	3 FLASHES	<ul style="list-style-type: none"> — Pressure switch circuit not closed. Induced draft blower is operating 	<ul style="list-style-type: none"> — Pressure switch hose blocked, pinched or connected improperly blocked flue or weak induced draft blower. — Incorrect pressure switch setpoint or malfunctioning switch contacts. — Loose or improperly connected wiring. 	<ul style="list-style-type: none"> — Inspect pressure switch hose. Repair if necessary, — Inspect flue for blockage, proper length, elbows, and termination. — Replace pressure switch. — Tighten or correct wiring connection. 	<ul style="list-style-type: none"> — Turn power OFF prior to repair. — Replace pressure switch with proper replacement part.

Table 14

Integrated control module will automatically attempt to reset from lockout after one hour.

LED Flash code will cease if power to the control module is interrupted through the disconnect or door switch. Refer to Section 11.4.

Symptoms of Abnormal Operation	Associated LED	Fault Description(s)	Possible Reason	Corrective Action	Cautions And Notes
<ul style="list-style-type: none"> — Circulator blower runs continuously. No furnace operation. — Integrated control module diagnostic LED is flashing FOUR (4) flashes. 	4 FLASHES	<ul style="list-style-type: none"> — Chamber limit switch - fixed circuit is open. — Fan mounted limit switch is open 	<ul style="list-style-type: none"> — Faulty chamber limit switch or fan mounted limit switch — Insufficient conditioned air over the heat exchanger. Blocked filters, restrictive ductwork, improper circulator blower speed or failed circulator blower. — Loose or improperly connected wiring. 	<ul style="list-style-type: none"> — Check chamber limit switch or fan mounted limit switch. Replace if necessary. — Check filters and duct work for blockage. Clean filters or remove obstruction. — Check circulator blower speed and performance. Correct speed or replace blower if necessary. — Tighten or correct wiring connection. 	<ul style="list-style-type: none"> — Turn power OFF prior to repair. — Replace chamber limit switch with proper replacement part. — Replace blower with correct replacement part. — Replace fan mounted limit switch with proper replacement part.
<ul style="list-style-type: none"> — Furnace fails to operate. — Integrated control module diagnostic LED is flashing FIVE (5) flashes. 	5 FLASHES	<ul style="list-style-type: none"> — Rollout switch - resettable open. 	<ul style="list-style-type: none"> — Flame rollout. — Misaligned burners, blocked flue, or failed induced draft blower. — Loose or improperly connected wiring. — Faulty rollout switch - resettable. 	<ul style="list-style-type: none"> — Check burners for proper alignment. — Check flue and air inlet piping for blockage, proper length, elbows and termination. Correct as necessary. — Check rollout switch - resettable. Replace if necessary. — Check induced draft blower for proper performance. Replace if necessary. — Tighten or correct wiring connection. 	<ul style="list-style-type: none"> — See Section 8 for piping details. — Replace induced draft blower with proper replacement part. — Replace rollout switch - resettable with correct replacement part.
<ul style="list-style-type: none"> — Induced draft blower runs continuously. — No furnace operation. — Integrated control module diagnostic LED is flashing SIX(6) flashes. 	6 FLASHES	<ul style="list-style-type: none"> — Polarity of 115 Volt power is reversed — Improper grounding 	<ul style="list-style-type: none"> — Polarity of 115 Volt AC power to furnace or integrated control module is reversed. — Red and blue wires to transformer are reversed. — Poor unit ground. 	<ul style="list-style-type: none"> — Review wiring diagram to correct polarity. — Verify proper ground. Correct if necessary — Reverse red and blue wires connected to transformer. 	<ul style="list-style-type: none"> — Turn power OFF prior to repair.

Table 15

Integrated control module will automatically attempt to reset from lockout after one hour.
LED Flash code will cease if power to the control module is interrupted.

Symptoms of Abnormal Operation	Associated LED	Fault Description(s)	Possible Reason	Corrective Action	Cautions And Notes
<ul style="list-style-type: none"> Abnormal furnace operation Integrated control module diagnostic LED is flashing SEVEN (7) flashes.. 	7 FLASHES	<ul style="list-style-type: none"> Flame sense microamp signal is low 	<ul style="list-style-type: none"> Flame sensor is coated/oxidized. Flame sensor is incorrectly positioned in the burner flame. Lazy burner flame due to Improper gas pressure or combustion air. 	<ul style="list-style-type: none"> Sand flame sensor. Inspect for proper sensor alignment. Compare current gas pressure to rating plate info. Adjust as needed. 	<ul style="list-style-type: none"> Turn power OFF prior to repair. Clean flame sensor with steel wool. See Section 8 for piping details. See rating plate for proper gas pressure.
<ul style="list-style-type: none"> Induced draft blower and circulator blower runs continuously. No furnace operation. Integrated control module diagnostic LED is flashing continuously. 	Continuous FLASHES	<ul style="list-style-type: none"> Flame sensed with no call for heat. 	<ul style="list-style-type: none"> Short to ground in flame sense circuit. 	<ul style="list-style-type: none"> Correct short at flame sensor or in flame sensor wiring 	<ul style="list-style-type: none"> Turn power OFF prior to repair.
<ul style="list-style-type: none"> Internal control failure 	Constant ON	<ul style="list-style-type: none"> Internal control failure 	<ul style="list-style-type: none"> Wrong electric power frequency Internal control failure 	<ul style="list-style-type: none"> Check electric power frequency Change control board 	<ul style="list-style-type: none"> Turn power OFF prior to repair.

Table 16

Integrated control module will automatically attempt to reset from lockout after one hour.

LED Flash code will cease if power to the control module is interrupted.

15 Service and Maintenance Procedures



WARNING: ELECTRICAL SHOCK, FIRE OR EXPLOSION HAZARD

Improper servicing could result in dangerous operation, serious injury, death or property damage.

- ▶ Before servicing, disconnect all electrical power to furnace.
- ▶ When servicing controls, label all wires prior to disconnecting. Reconnect wires correctly.
- ▶ Verify proper operation after servicing.



WARNING: FIRE, EXPLOSION OR CARBON MONOXIDE POISONING HAZARD

- ▶ Failure to replace with proper control could result in fire, explosion or carbon monoxide poisoning.
- ▶ Replace ONLY with the same model number or as specified by the manufacturer.

15.1 Annual Inspection

The furnace must be inspected by a qualified installer or service agency at least once per year. Inspect the furnace at the beginning of the heating season. This will ensure that all furnace components are in proper working order and that the heating system functions appropriately. Pay particular attention to the following items. Repair or service as necessary.

- a. All flue gas carrying areas external to the furnace (i.e. chimney, vent connector, vent pipe) are clear and free of obstructions.
- b. Inspect heat exchangers and blowers for corrosion, deterioration, or deposits of debris. Remove any obstructions.
- c. The vent connector is in place, slopes upward and is physically sound without holes or excessive corrosion.
- d. The return-air duct connection(s) is physically sound, is sealed to the furnace casing, and terminates outside the space containing the furnace.
- e. The physical support of the furnace is sound without sagging, cracks, gaps, etc. around the base so as to provide a seal between the support and the base.
- f. There are no obvious signs of deterioration of the furnace.
- g. The pilot and burner flames are in good adjustment (by comparison with pictorial sketches or drawings of the main burner flame and, if applicable, the pilot burner flame, refer to the Installation, Operation, and Maintenance Manual for more information).
- h. Check the condensate drain and trap for leaks and cracks. Fill the trap with water. Clean the drain and trap. The trap must be filled with water and the drain and trap should be cleaned.

15.2 Filters

A return air filter is not supplied with this furnace; however there must be a means of filtering the return air. The installer must supply filter(s) at the time of installation.

Filter maintenance

Improper filter maintenance is the most common cause of inadequate heating or cooling performance. Clean permanent filter or replace disposable filter once a month or more frequently as required. When replacing a filter, it must be replaced with a filter of the same type and size.

Become familiar with filter location and procedures for removal cleaning and replacing them. If help is needed, contact the installer of the furnace or a qualified service person.

Filter removal

Depending on the installation, differing filter arrangements can be applied. A media air filter or electronic air cleaner can be used as an alternate filter.

Follow the filter sizes given in the Recommended Minimum Filter size (Table 3, page 18) to ensure proper unit performance.

For further details, see your distributor.

Upright filter removal

To remove filters from an external filter rack in an upright upflow installation, follow the directions provided with external filter rack kit.

Clean, wash and dry a permanent filter. When using a permanent filter, both sides should be sprayed with a dust adhesive as recommended on the adhesive container. Spray adhesives for use with permanent filters can be found at some hardware stores. BE SURE AIRFLOW DIRECTION ARROW POINTS TOWARDS THE BLOWER.

Inspect filter. If your dirty filter is the disposable type, replace dirty filter with the same type and size filter. If your dirty filter is a permanent filter, clean as follows:

- ▶ Clean, wash, and dry a permanent filter. When using a permanent filter, both sides should be sprayed with a dust adhesive as recommended on the adhesive container.
- ▶ If badly torn or uncleanable, these filters must be replaced by equal size permanent, high velocity filters. Throwaway filters must not be used as replacement for permanent filters.

15.3 Induced Draft And Circulating Blower Motors

The bearings in the induced draft blower and circulator blower motors are permanently lubricated by the manufacturer. No further lubrication is required. Check motor windings for accumulation of dust which may cause overheating. Clean as necessary.

15.4 Flame Sensor (Qualified Service Technicians Only)

Under some conditions the fuel or air supply can create a nearly invisible coating on the flame sensor. This coating acts as an insulator causing a drop in the flame sense signal. If the flame sense signal drops too low, the furnace will not sense the flame and will lock out. The flame sensor should be carefully cleaned by a qualified service technician using emery cloth or steel wool. Following cleaning, the flame sense signal should be 1 to 6 microamps at 115 volts.

15.5 Burners



WARNING: FIRE, EXPLOSION, ELECTRICAL SHOCK OR CARBON MONOXIDE POISONING HAZARD

- ▶ To avoid personal injury or death. Do not remove any internal compartment covers or attempt any adjustment. Electrical components are contained in both compartments. Contact a qualified service agent at once if an abnormal flame appearance should develop.

Periodically during the heating season perform a visual check of the burner flames. Turn the furnace on at the thermostat. Wait a few minutes since any dislodged dust will alter the normal flame appearance. Flames should be stable quiet soft and blue with slightly orange tips. They should not be yellow. They should extend directly outward from the burner ports without curling downward floating or lifting off the ports. See Figure 31 (page 35). Contact a qualified service agent at once if an abnormal flame appearance should develop.



Only a qualified contractor, installer or service agency can clean the burners, if the burners get a heavy accumulation of soot and carbon.

15.6 Inspecting the Heat Exchanger

The following must be performed by a qualified service agency:



If the heat exchangers get a heavy accumulation of soot and carbon, they must be replaced rather than cleaning them. A heavy build-up of soot and carbon indicates that a problem exists which needs to be corrected, such as improper adjustment of manifold pressure, insufficient or poor quality combustion air, incorrect size or damaged manifold orifice(s), improper gas, or a restricted heat exchanger. In these scenarios, the heat exchanger must be replaced.

Inspect the heat exchanger for excessive rust, cracks, or holes. Visual inspection is always best, but requires training and practice. There are tools (field supplied) available to assist, such as inspection cameras and dye penetration inspection systems. Inspect the metal flue for rust or holes, and make sure it's supported properly.

15.7 Repair and Replacement Parts

- ▶ When ordering any of the listed functional parts, be sure to provide the furnace model and serial numbers with the order.
- ▶ Parts are available from your distributor.

16 Before Leaving Installation

- ▶ Cycle the furnace with the thermostat at least three times. Verify cooling (if applicable) and fan only operation.
- ▶ Review the manual with the homeowner and discuss proper furnace operation and maintenance.
- ▶ Leave literature packet near furnace.

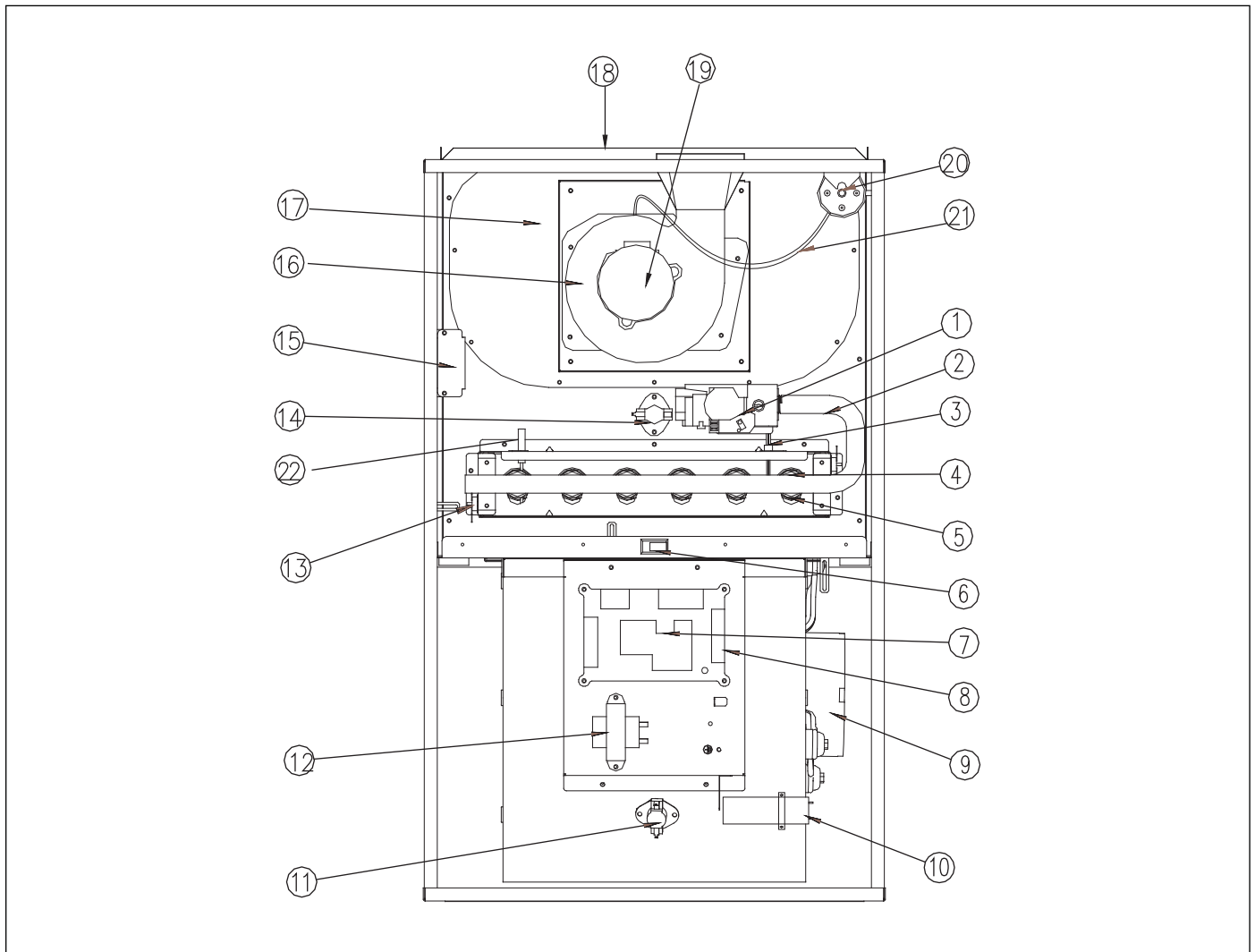

Figure 32

COMPONENT IDENTIFICATION:

- | | |
|-----------------------------------|----------------------------------|
| 1. Single Stage Gas Valve | 12. Transformer |
| 2. Gas Manifold | 13. Rollout Switch - Resettable |
| 3. Mini Igniter | 14. Chamber Limit Switch - Fixed |
| 4. Natural/Propane Gas Orifice | 15. Junction Box |
| 5. Burner | 16. Induced Draft Blower |
| 6. Door Switch | 17. Flue Collector Box |
| 7. Integrated Control Module | 18. Heat Exchanger |
| 8. 24 Volt Thermostat Connections | 19. Blower Wheel |
| 9. Blower | 20. Pressure Switch |
| 10. Capacitor | 21. Pressure Switch Hose |
| 11. Fan Mounted Limit Switch | 22. Flame Sensor |

Please contact your local installer or dealer for replacement parts.

United States and Canada

**Bosch Thermotechnology Corp.
65 Grove Street
Watertown, MA 02472**

**Tel: 866-642-3198
Fax: 603-965-7581
www.boschheatingandcooling.com**