

PROJECT:	
MODEL #:	
ITEM #:	QTY:
AVAILABLE W/H:	APPROVAL:

Countertop Glass Door Merchandiser



BAGR7W-HC

STANDARD FEATURES

Cabinet construction

- Black or white painted steel exterior and white painted steel interior.
- High density foamed in place polyurethane insulation – Environmentally safe.
- Sturdy, epoxy coated wire shelves with adjustable shelving height.
- 1" adjustable legs for leveling

Refrigeration

- Hydrocarbon refrigerants (R-290) – increases energy efficiency by up to 25% compared to using HFC refrigerants. It is safer for the environment and does not cause ozone depletion.

- Self-contained system, back mounted compressor provides quick and easy maintenance
- Epoxy coated evaporator reduces potential corrosion.
- Refrigerator has a temperature range between 33°F ~ 39°F

Doors

- Durable door gasket with easy replacement. Self-adjusting magnetic gaskets
- Thick heavy duty Insulation
- Triple pane glass – reduces condensation and increases cooling efficiency

Design & Features

- Compact table top design.

Lighting

- LED interior lighting.

Standard

- NSF/ANSI Standard 7 compliant

Connection

- 9 ft long flexible three wire cord with molded plug

Optional Features & Accessories

- Additional Shelves are available

Countertop Glass Door Merchandiser

PRODUCT PLAN VIEW

- Top View -

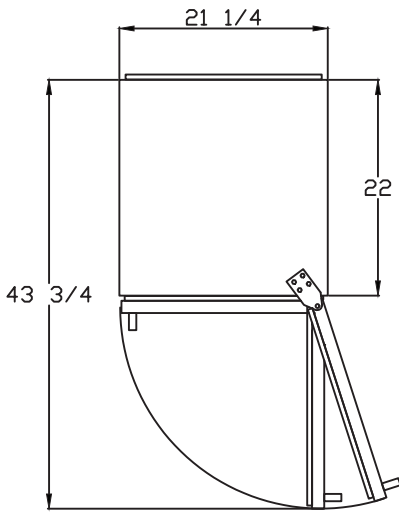

- Front View -

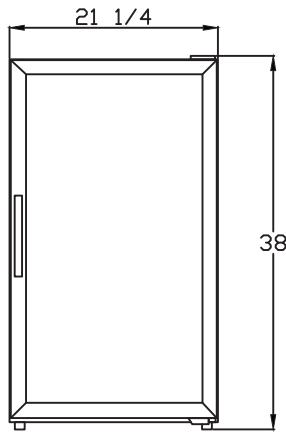

- Side View -

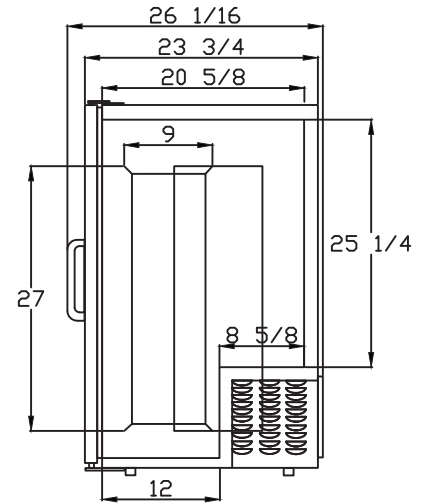

BAGR7W-HC

PRODUCT SPECIFICATION

Model	Product Description			Refrigerant	Temperature Range	Easy Maintenance			Cord Length (ft/m)			
	Countertop Glass Door Merchandiser			R-290	33°F ~ 39°F	Sliding Condensing Unit			9.8ft (3m)			
	Doors	Capacity (Cu.Ft.)	Shelves	Cabinet Dimensions (inches / mm)			HP	Voltage	Amps	NEMA config.	Weight (lbs / kg)	
L				D	H	Net Weight					Ship Weight	
BAGR7W-HC	1	7	2	21 1/4" (540mm)	23 3/4" (600mm)	38" (965mm)	1/5	115V / 60Hz	3.1	NEMA 5-15	132 (60)	144 (65)

*BLUE AIR has the right to change specifications without further notice.