

Installer's Guide

Convertible Air Handlers 1-1/2 – 5 Ton

TEM4A0B18S21SB
TEM4A0B24S21SB
TEM4A0B30S31SB
TEM4A0B36S31SB
TEM4A0C37S31SB
TEM4A0C42S41SB
TEM4A0C48S41SB
TEM4A0C60S51SB

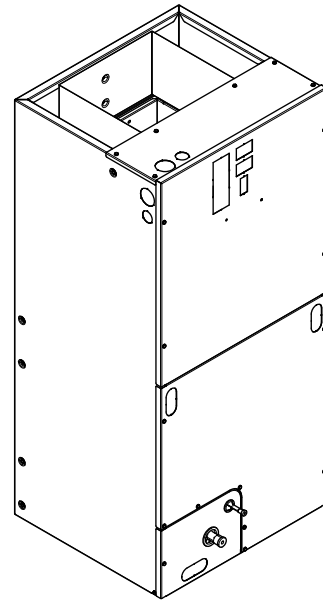

The TEM4 series air handler is designed for installation in a closet, utility room, alcove, basement, crawlspace or attic. These versatile units are applicable to air conditioning and heat pump applications. Several models are available to meet the specific requirements of the outdoor equipment. Field installed electric resistance heaters are available.

▲ SAFETY WARNING

Only qualified personnel should install and service the equipment. The installation, starting up, and servicing of heating, ventilating, and air-conditioning equipment can be hazardous and requires specific knowledge and training. Improperly installed, adjusted or altered equipment by an unqualified person could result in death or serious injury. When working on the equipment, observe all precautions in the literature and on the tags, stickers, and labels that are attached to the equipment.

SAFETY SECTION

AIR HANDLERS

Important: This document contains a wiring diagram, a parts list, and service information. This is customer property and is to remain with this unit. Please return to service information pack upon completion of work.

Important: These instructions do not cover all variations in systems nor provide for every possible contingency to be met in connection with the installation. Should further information be desired or should particular problems arise which are not covered sufficiently for the purchaser's purposes, the matter should be referred to your installing dealer or local distributor.

⚠ WARNING

HAZARDOUS VOLTAGE!

Failure to follow this Warning could result in property damage, severe personal injury, or death.

Disconnect all electric power, including remote disconnects before servicing. Follow proper lockout/tagout procedures to ensure the power cannot be inadvertently energized.

⚠ CAUTION

GROUNDING REQUIRED!

Failure to inspect or use proper service tools may result in equipment damage or personal injury.

Reconnect all grounding devices. All parts of this product that are capable of conducting electrical current are grounded. If grounding wires, screws, straps, clips, nuts, or washers used to complete a path to ground are removed for service, they must be returned to their original position and properly fastened.

⚠ WARNING

LIVE ELECTRICAL COMPONENTS!

Failure to follow this Warning could result in property damage, severe personal injury, or death.

Follow all electrical safety precautions when exposed to live electrical components. It may be necessary to work with live electrical components during installation, testing, servicing, and troubleshooting of this product.

⚠ WARNING

PRESSURIZED REFRIGERANT!

Failure to follow this Warning could result in personal injury

System contains oil and refrigerant under high pressure. Recover refrigerant to relieve pressure before opening the system. Do not use non-approved refrigerants or refrigerant substitutes or refrigerant additives.

⚠ CAUTION

SHARP EDGE HAZARD!

Failure to follow this Caution could result in property damage or personal injury.

Be careful of sharp edges on equipment or any cuts made on sheet metal while installing or servicing.

⚠ CAUTION

HAZARDOUS VAPORS!

Failure to follow this caution could result in property damage or personal injury.

Equipment corrosion damage. To prevent shortening its service life, the air handler should not be used during the finishing phases of construction or remodeling. The low return air temperatures can lead to the formation of condensate. Condensate in the presence of chlorides and fluorides from paint, varnish, stains, adhesives, cleaning compounds, and cement creates a corrosive condition which may cause rapid deterioration of the cabinet and internal components.

⚠ CAUTION

COIL IS PRESSURIZED!

- Coil is pressurized with approximately 8–12 psi dry air and factory checked for leaks.
- Carefully release the pressure by removing the rubber plug on the liquid line.
- If no pressure is released, check for leaks.

⚠ WARNING

SAFETY HAZARD!

Fiberglass dust and ceramic fibers are believed by the state of California to cause cancer through inhalation. Glasswool fibers may also cause respiratory, skin, or eye irritation.

PRECAUTIONARY MEASURES

- Avoid breathing fiberglass dust
- Use a NIOSH approved dust/mist respirator
- Avoid contact with the skin or eyes. Wear long-sleeved, loose fitting clothing, gloves, and eye protection
- Wash clothes separately from other clothing, rinse washer thoroughly
- Operations such as sawing, blowing, tear-out, and spraying may generate fiber concentrations requiring additional respiratory protection. Use the appropriate NIOSH approved respirator in these situations

FIRST AID MEASURES

- **EYE CONTACT:** FLUSH EYES WITH WATER TO REMOVE DUST. IF SYMPTOMS PERSIST, SEEK MEDICAL ATTENTION.
- **SKIN CONTACT:** WASH AFFECTED AREA GENTLY WITH SOAP AND WARM WATER AFTER HANDLING.

This warning complies with state of California law, Proposition 65.

Note: Air handlers have been evaluated in accordance with the Code of Federal Regulations, Chapter XX, Part 3280 or the equivalent. "SUITABLE FOR MOBILE HOME USE."

Note: Condensation may occur on the surface of the air handler when installed in an unconditioned space. When units are installed in unconditioned spaces, verify that all electrical and refrigerant line penetrations on the air handler are sealed completely.

Note: The manufacturer recommends installing ONLY A.H.R.I approved, matched indoor and outdoor systems. Some of the benefits of installing approved matched indoor and outdoor split systems are maximum efficiency, optimum performance, and the best overall system reliability.

⚠ WARNING

SAFETY HAZARD!

This appliance is not to be used by persons (including children) with reduced physical, sensory, or mental capabilities, or lack of experience and knowledge, unless they have been given supervision or instruction.

⚠ WARNING

SAFETY HAZARD!

Children should be supervised to ensure that they do not play with the appliance.

Important: Installation of this unit shall be made in accordance with the National Electric Code, NFPA No. 90A and 90B, and any other local codes or utilities requirements.

Important: Air handlers do not require repositioning of the coil or drain pan for upflow or horizontal left applications. See the downflow and horizontal right installation sections for application instructions.

Table of Contents

Features	5	Outline Drawing	18
Installation Instructions.....	6	Heater Pressure Drop Table TEM Air Handler Models	19
Field Wiring	9	Coil Conversion Instructions.....	20
Electrical Data	10	Coil Conversion	23
Performance and Electrical Data	11	Checkout Procedures	29
Minimum Airflow CFM	17		

Features

Table 1. Standard Features

- MULTI-POSITION UPFLOW, DOWNFLOW, HORIZONTAL LEFT AND HORIZONTAL RIGHT
- PAINTED FINISH ON GALVANIZED STEEL EXTERIOR WITH FULLY INSULATED CABINET THAT MEETS R4.2 VALUE
- STURDY POLYCARBONATE DRAIN PANS
 - The TEM air handler has factory installed drain pans and is shipped for upflow and horizontal left applications
- 208/230 VAC OPERATION
- MULTI-SPEED DIRECT DRIVE BLOWER.
- FACTORY INSTALLED R-410A THERMAL EXPANSION VALVE
- ALL ALUMINUM COIL
- BOTTOM RETURN
- MEETS THE MINIMUM LEAKAGE REQUIREMENTS FOR THE FLORIDA AND CALIFORNIA BUILDING CODES

Table 2. Optional Accessories

- 4,5,8,10,15, 20 and 25 KW SINGLE PHASE ELECTRIC HEATERS
 - Circuit breakers available on all single phase 4, 5, 8, 10, 15, 20 and 25 KW heaters
 - Lug terminals available on all single phase 4, 5, 8, and 10 KW heaters
- 10 and 15 KW THREE PHASE ELECTRIC HEATERS
 - Heaters available with lug terminals
- SINGLE POINT POWER ENTRY KIT (for 15 and 20 KW Heaters)
- SUPPLY DUCT FLANGE KIT
- DOWNFLOW WATER MANAGEMENT KIT - BAYTEMDFKT1A (required for 5 Ton models)
- DOWNFLOW SUB-BASE KITS - TAYBASE185, TAYBASE235
- R-22 CONVERSION KITS — BAYATXV1836B, BAYATXV4248B, BAYATXV6161B
- SLIM FIT FILTER BOX KIT — BAYSF1185AAA, BAYSF1235AAA

Installation Instructions

1. Unpacking

Carefully unpack the unit and inspect the contents for damage. If any damage is found at the time of delivery, proper notification and claims should be made with the carrier.

Check the rating plate to assure model number and voltage, plus any kits match with what you ordered. The manufacturer should be notified within 5 days of any discrepancy or parts shortage.

2. Location

The air handler should be centrally located and may be installed in a closet, alcove, utility room, basement, crawl space or attic. Minimum clearances must be met.

Important: The downflow sub-base may be required with electric heat applications. See minimum clearance table.

Important: A downflow condensate management kit BAYTEMDFKT1A is required and must be ordered separately for downflow applications of all 5-ton air handlers.

The unit should be installed in a level position to ensure proper condensation drainage. Up to an additional 1/4" rise over the width or depth of the unit is allowed to create additional sloping towards the drain. Unit must be positioned between level and 1/4" rise, sloping toward the drain connections.

When the unit is installed in a closet or utility room, the room should be large enough, and have an opening to allow replacement of the unit. All servicing is done from the front and a clearance of 21" is needed for service unless the closet door aligns with the front of the air handler.

If you are installing the unit in an unconditioned space such as an attic or crawl space, you must ensure that the area provides sufficient air circulation to prevent moisture collection on the cabinet during high dew point conditions. A drain pan must be installed under the entire unit when it is installed in or above a finished ceiling or in an unconditioned space.

3. Duct Work

The duct work should be installed in accordance with the NFPA No. 90A "Installation of Air Conditioning and Ventilating systems" and No. 90B "Residential Type Warm Air Heating and Air Conditioning Installation."

The duct work should be insulated in accordance with the applicable requirements for the particular installation as required by HUD, FHA, VA the applicable building code, local utility or other governing body.

4. Condensate Drain

The unit is supplied with primary and auxiliary condensate drains that have 3/4" NPT connections. The primary drain must be trapped outside the unit and piped in accordance with applicable building codes.

The figure shows the operation of a properly designed trap under normal operating conditions when the blower is running and the condensate is draining. Note the difference in height of the water column must at least equal the normal negative static pressure existing during operation between the cooling coil and blower. It is advisable to have the difference in water column height somewhat greater than the normal maximum operating static to allow for greater static caused by dirty filters or for the bounce of the water column on start up.

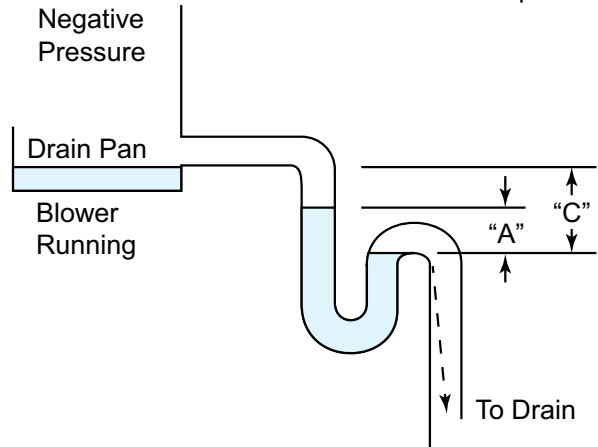

Proper operation of condensate trap under normal operating conditions.

"A" height of water column equals negative static pressure existing in system.

"C" dimension should at least equal two times the maximum negative static pressure that can occur in system.

Do not reduce the drain line size less than the connection size on the drain pan. Condensate should be piped to an open drain or to the outside. All drains must pitch downward away from the unit a minimum of 1/4" per foot of line to ensure proper drainage.

Important: If cleanout Tee is used, stand pipe must be sealed/capped.

Important: If a vent Tee is used, it must be downstream from the trap.

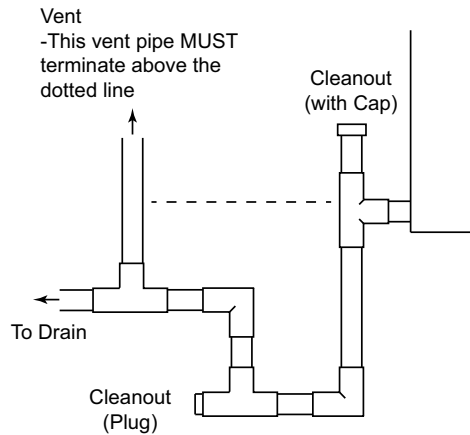

Insulate the primary drain line to prevent sweating where dew point temperatures may be met. (Insulation is optional depending on climate and application needs.)

5. Refrigerant Piping

Refrigerant piping external to the unit shall be sized in accordance with the instructions of the manufacturer of the outdoor equipment.

6. Metering Device

All units are shipped and installed with an internally-checked, bleed TXV designed for air conditioning or heat pump operation. Pressures equalize after shut down. Some outdoor models may require a start assist kit. See outdoor unit for more information.

7. Blower

This unit is supplied with a multi-speed motor with a direct drive blower wheel which can obtain various air flows. The unit is shipped with factory set cooling and heating speed taps. Airflow performance tables are available for additional speed taps. Disconnect all power to the unit before making any adjustments to the motor speed taps. Be sure to check the air flow and the temperature drop across the evaporator coil to ensure sufficient air flow.

8. Wiring

Consult all schematic and pictorial wiring diagrams of this unit and the outdoor equipment to determine compatibility of wiring connections and to determine specific requirements.

All field wiring to the air handler should be installed in accordance with the latest edition of the National Electric Code NFPA No. 70 and any local codes. Check rating plates on unit for rated volts, minimum circuit ampacity and maximum over current protection. Supply circuit power wiring must be 75 degree C (167 degree F) minimum copper conductors only. Copper supply wires shall be sized to the National Electric Code or local code requirements, whichever is more stringent.

The unit is shipped wired for 230/240 Volt AC 60 HZ 1 Phase Operation. If the unit is to be operated at 208 VAC 60HZ, follow the instructions on the indoor unit wiring diagram to change the low voltage transformer to 208 VAC operation (Ensure unit is properly grounded).

Class 2 low voltage control wiring should not be run in conduit with power wiring and must be separated from power wiring unless class 1 wire with proper voltage rating is used.

Low voltage control wiring should be 18 Awg, color coded (105 degree C minimum). For lengths longer than 100ft., 16 Awg wire should be used. Make certain that separation of control wiring and power wiring has been maintained.

9. Air Filter

To protect the coil, blower and other internal parts from excessive dirt and dust an air filter must be installed before air enters the evaporator coil. A remote filter must be installed. Consult the filter manufacturer for proper sizing and maximum velocity requirements.

10. Thermostat

Select a thermostat that is commonly used with HP or AC single stage heating/cooling with electric heat. The thermostat will energize the fan on a demand for heat or cool.

Install the thermostat on an inside wall, away from drafts, lights or other heat sources in a location that has sufficient air circulation from other rooms being controlled by the thermostat.

11. Sequence of Operation Cooling (Cooling only)

PSC versions - When the thermostat calls for cooling, the circuit from R to G is completed. The blower relay is energized.

Constant torque version - When the thermostat calls for cooling, the circuit from R to G is completed. The blower motor is energized directly by the 24VAC signal from the thermostat.

The circuit from R to Y is also complete energizing the compressor contactor of the outdoor unit. The contactor will close and start the compressor and condenser fan motor.

Cooling (heat pump)

PSC versions - When the thermostat calls for cooling, the circuit from R to G is completed. The blower relay is energized.

Constant torque version - When the thermostat calls for cooling, the circuit from R to G is completed. The blower motor is energized directly by the 24VAC signal from the thermostat.

The circuit from R to Y is also complete energizing the compressor contactor of the outdoor unit. The contactor will close and start the compressor and

condenser fan motor.

Circuit R to O energizes the reversing valve to the cooling position.

Heating (heat pump)

PSC versions - When the thermostat calls for heating, the circuit from R to G is completed. The blower relay is energized.

Constant torque version – When the thermostat calls for heating, the circuit from R to G is completed and the blower motor is energized directly by the 24VAC signal from the thermostat.

The circuit from R to Y is also complete energizing the compressor contactor of the outdoor unit. The contactor will close and start the compressor and condenser fan motor.

In the heating mode, the reversing valve of the outdoor unit is not energized.

If the indoor temperature continues to fall, the R to W circuit is completed energizing the electric heat contactor(s).

Heating (electric heat only)

Note: *The thermostat must be setup to bring the blower on when the electric heat is energized.*

PSC versions - When the thermostat calls for heating, the circuit from R to G is completed. The blower relay is energized. The circuit from R to W is completed energizing the heating contactor(s).

Constant torque version - When the thermostat calls for heating, the circuit from R to G is completed and the blower motor is energized directly by the 24VAC signal from the thermostat. The circuit from R to W is completed energizing the heating contactor(s).

Defrost

Supplemental heat during defrost can be provided by connecting the X2 (black) wire from the outdoor unit to W1 or W2 at the indoor unit. This will prevent cold air from being discharged from the indoor unit during defrost.

12. Operational and Checkout Procedures

To obtain proper performance, all units must be operated and charge adjustments made in accordance with procedures found in the Service Facts document of the outdoor unit. After installation has been completed, it is recommended that the entire system be checked against the checkout list located at the back of this document. See “[Checkout Procedures](#),” p. 29

13. Maintenance

The system air filter(s) should be inspected, cleaned or replaced at least monthly. Make certain that the access panels are replaced and secured properly before placing the unit back in operation. This product is designed for dependable service; however, periodic maintenance should be scheduled and conducted by trained professional service personnel. This service should be conducted at least annually, and should include testing and inspection of electrical and refrigerant components. The heat transfer surface should be cleaned. The blower motor is permanently lubricated for normal operating conditions.

Field Wiring

Figure 1. Field Wiring Diagrams

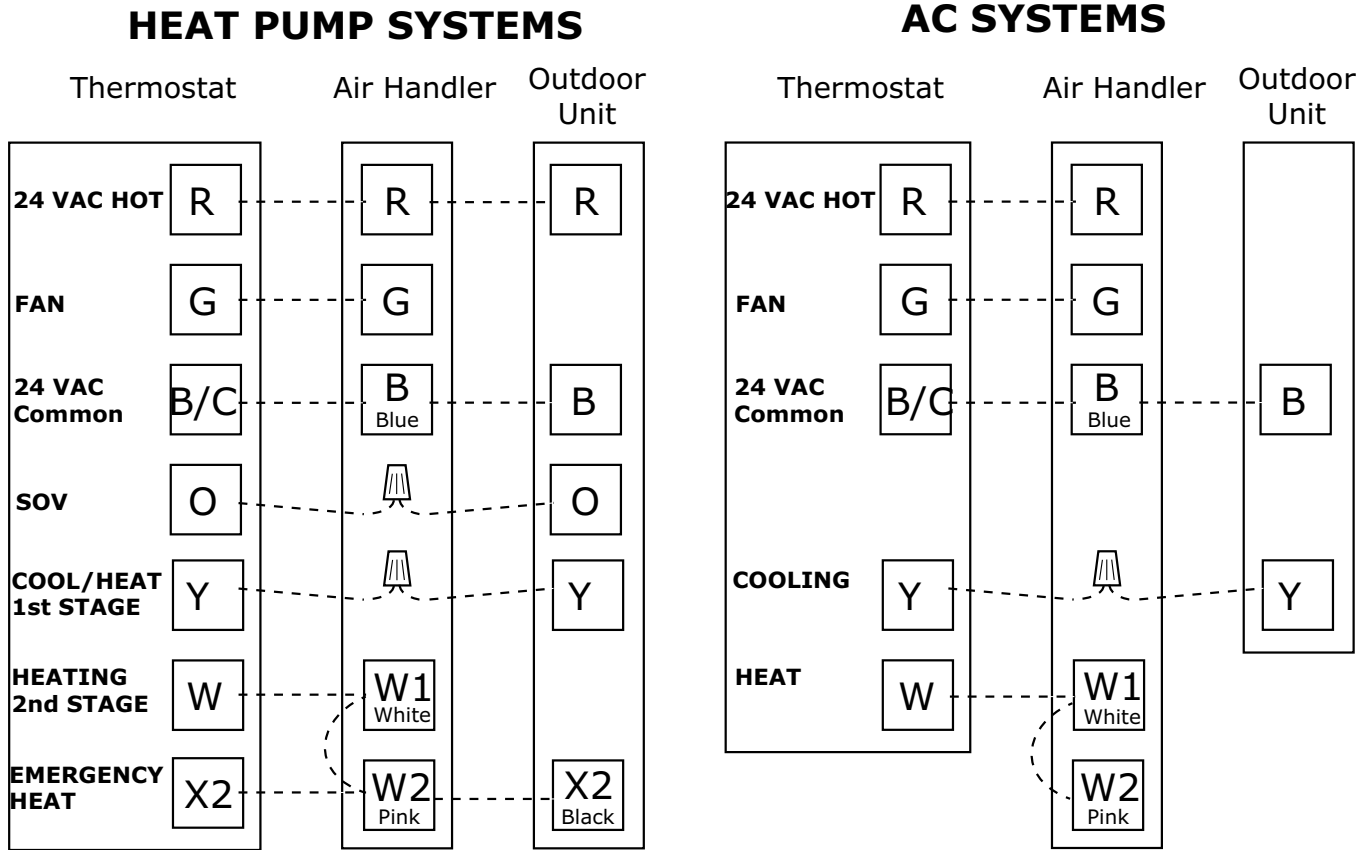

In AC systems for multiple stages of electric heat, jumper W1 and W2 together if comfort control has only one stage of heat.

Electrical Data

Figure 2. TEM4A0B18-C37

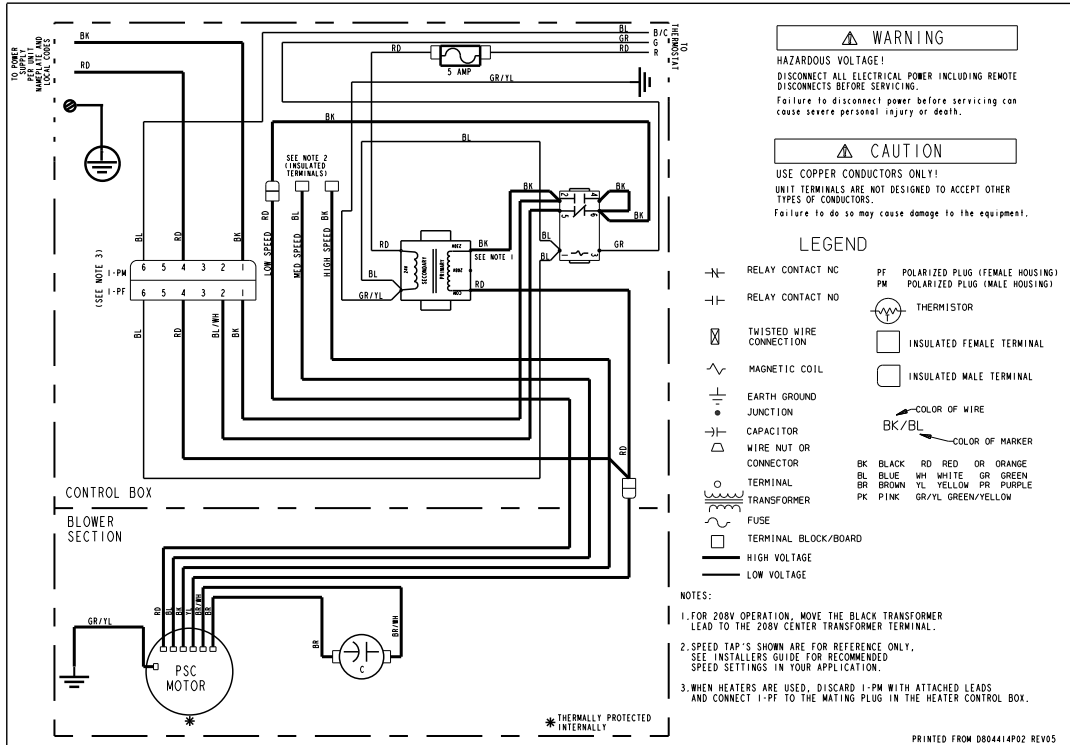
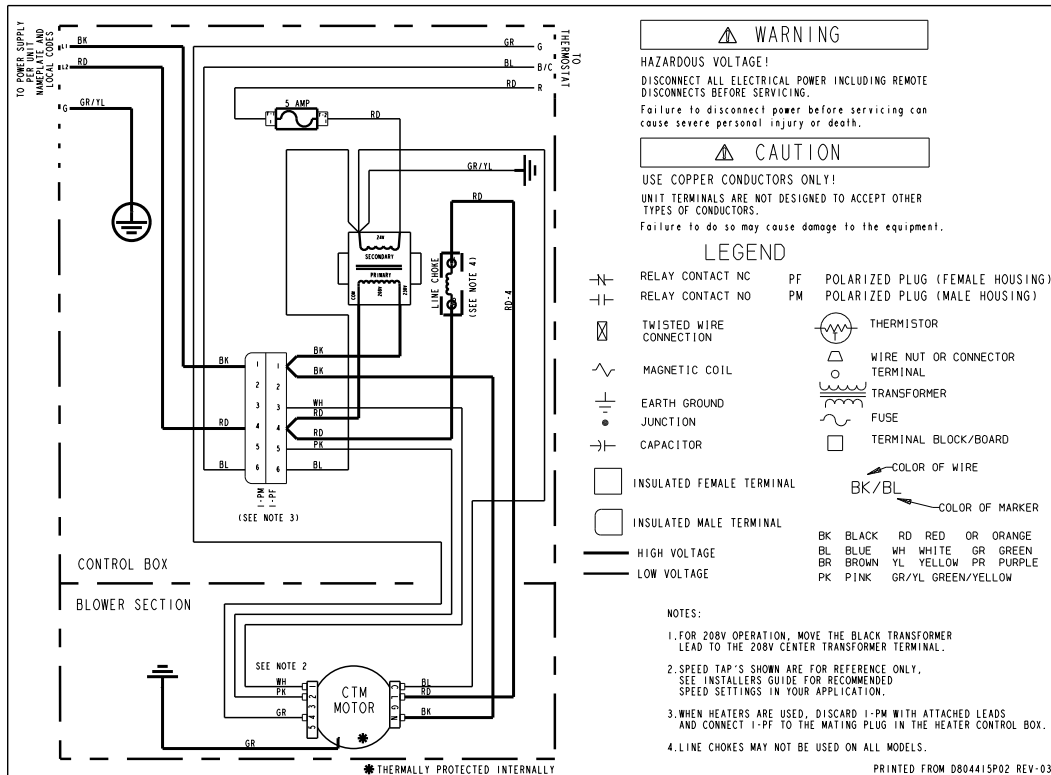

Figure 3. TEM4A0C42-C60



Performance and Electrical Data

Table 3. Air Flow Performance

TEM4A0B18S21SB, TEM4A0B24S21SB (a)						
EXTERNAL STATIC (in w.g)	AIRFLOW					
	Speed Taps — 230 VOLTS			Speed Taps — 208 VOLTS		
	High	Med	Low †	High	Med	Low †
0.1	1094	927	773	1052	849	658
0.2	1032	880	735	990	807	624
0.3	955	818	678	915	750	578
0.4	864	739	601	826	679	518
0.5	759	645	505	723	591	441
0.6	639	534	389	606	490	
0.7	505	408		476	374	

1. Values are with wet coil, no filter, and no heaters
 2. CFM Correction for dry coil = Add 3%
 3. † = Factory setting

(a) For the TEM4A0B24S21SB, the recommended speed tap is medium at 0.4" external static pressure.

Table 4. Electrical Data

TEM4A0B18S21SB, TEM4A0B24S21SB											
Heater Model No.	No. of Circuits/ Phases	240 Volt					208 Volt				
		Capacity		Heater Amps per Circuit	Minimum Circuit Ampacity	Maximum Overload Protection	Capacity		Heater Amps per Circuit	Minimum Circuit Ampacity	Maximum Overload Protection
		kW	BTUH				kW	BTUH			
No Heater				1.2 *	2	15			1.2 *	2	15
BAYHTR1504BRK BAYHTR1504LUG	1/1	3.84	13100	16.0	22	25	2.88	9800	13.8	19	20
BAYHTR1505BRK BAYHTR1505LUG	1/1	4.80	16400	20.0	27	30	3.60	12300	17.3	23	25
BAYHTR1508BRK BAYHTR1508LUG	1/1	7.68	26200	32.0	42	45	5.76	19700	27.7	36	40
BAYHTR1510BRK BAYHTR1510LUG	1/1	9.60	32800	40.0	52	60	7.20	24600	34.6	45	45
BAYHTR3510LUG	1/3	9.60	32800	23.1	30	30	7.20	24600	20.0	26	30

* = Motor Amps

Performance and Electrical Data

Table 5. Air Flow Performance

TEM4A0B30S31SB, TEM4A0B36S31SB						
EXTERNAL STATIC (in w.g)	AIRFLOW					
	Speed Taps — 230 VOLTS			Speed Taps — 208 VOLTS		
	High	Med	Low †	High	Med	Low †
0.1	1391	1305	1059	1338	1146	902
0.2	1305	1231	1029	1257	1098	868
0.3	1203	1138	970	1159	1027	817
0.4	1083	1027	884	1044	935	753
0.5	948	899	769	913	823	664
0.6	795	752	626	766	692	
0.7	626	587		603	542	

1. Values are with wet coil, no filter, and no heaters
 2. CFM Correction for dry coil = Add 3%
 3. † = Factory setting
 4. In downflow applications, airflow must not exceed 1200 cfm due to condensate blowoff.

Table 6. Electrical Data

TEM4A0B30S31SB, TEM4A0B36S31SB											
Heater Model No.	No. of Circuits/ Phases	240 Volt					208 Volt				
		Capacity		Heater Amps per Circuit	Minimum Circuit Ampacity	Maximum Overload Protection	Capacity		Heater Amps per Circuit	Minimum Circuit Ampacity	Maximum Overload Protection
		kW	BTUH				kW	BTUH			
No Heater				2.0 *	3	15			2.0 *	3	15
BAYHTR1504BRK BAYHTR1504LUG	1/1	3.84	13100	16.0	23	25	2.88	9800	13.8	20	20
BAYHTR1505BRK BAYHTR1505LUG	1/1	4.8	16400	20.0	28	30	3.6	12300	17.3	24	25
BAYHTR1508BRK BAYHTR1508LUG	1/1	7.68	26200	32.0	43	45	5.76	19700	27.7	37	40
BAYHTR1510BRK BAYHTR1510LUG	1/1	9.6	32800	40.0	53	60	7.2	24600	34.6	46	50
BAYHTR1517BRK- Circuit 1 ^(a)	2/1	9.6	32800	40.0	53	60	7.2	24600	34.6	46	50
BAYHTR1517BRK- Circuit 2		4.8	16400	20.0	25	25	3.6	12300	17.3	22	25
BAYHTR3510LUG	1/3	9.6	32800	23.1	31	35	7.2	24600	20.0	27	30
BAYHTR3517LUG	1/3	14.4	49100	34.6	45	50	10.8	36900	30.0	40	40
BAYHTR1517BRK with single circuit power source kit BAYSPEKT201A	1/1	14.4	49100	60.0	83	90	10.8	36900	51.9	73	80

* = Motor Amps

^(a) MCA and MOP for circuit 1 contains the motor amps

Table 7. Air Flow Performance

TEM4A0C37S31SB						
EXTERNAL STATIC (in w.g)	AIRFLOW					
	Speed Taps — 230 VOLTS			Speed Taps — 208 VOLTS		
	High	Med	Low †	High	Med	Low †
0.1	1959	1704	1344	1786	1465	1154
0.2	1898	1675	1332	1748	1462	1126
0.3	1828	1631	1325	1697	1444	1108
0.4	1750	1574	1310	1633	1410	1095
0.5	1662	1504	1277	1557	1359	1076
0.6	1563	1420	1223	1468	1289	1039
0.7	1452	1321		1365		

1. Values are with wet coil, no filter, and no heaters
 2. CFM Correction for dry coil = Add 3%
 3. † = Factory setting
 4. The recommended speed tap is low at 0.5" external static pressure.
 5. In downflow applications, airflow must not exceed 1600 cfm due to condensate blowoff.

Table 8. Electrical Data

TEM4A0C37S31SB											
Heater Model No.	No. of Circuits/ Phases	240 Volt					208 Volt				
		Capacity		Heater Amps per Circuit	Minimum Circuit Ampacity	Maximum Overload Protection	Capacity		Heater Amps per Circuit	Minimum Circuit Ampacity	Maximum Overload Protection
		kW	BTUH				kW	BTUH			
No Heater				2.5 *	3	15			2.5 *	3	15
BAYHTR1504BRK BAYHTR1504LUG	1/1	3.84	13100	16.0	23	25	2.88	9800	13.8	20	20
BAYHTR1505BRK BAYHTR1505LUG	1/1	4.8	16400	20.0	28	30	3.6	12300	17.3	25	25
BAYHTR1508BRK BAYHTR1508LUG	1/1	7.68	26200	32.0	43	45	5.76	19700	27.7	38	40
BAYHTR1510BRK BAYHTR1510LUG	1/1	9.6	32800	40.0	53	60	7.2	24600	34.6	46	50
BAYHTR1517BRK- Circuit 1 ^(a)	2/1	9.6	32800	40.0	53	60	7.2	24600	34.6	46	50
BAYHTR1517BRK- Circuit 2		4.8	16400	20.0	25	25	3.6	12300	17.3	22	25
BAYHTR1523BRK- Circuit 1 ^(a)	2/1	9.6	32800	40.0	53	60	7.2	24600	34.6	46	50
BAYHTR1523BRK- Circuit 2		9.6	32800	40.0	50	50	7.2	24600	34.6	43	45
BAYHTR3510LUG	1/3	9.6	32800	23.1	32	35	7.2	24600	20.0	28	30
BAYHTR3517LUG	1/3	14.4	49100	34.6	46	50	10.8	36900	30.0	40	40

* = Motor Amps

^(a) MCA and MOP for circuit 1 contains the motor amps

Performance and Electrical Data

Table 9. Air Flow Performance

TEM4A0C42S41SB			
EXTERNAL STATIC (in w.g)	AIRFLOW		
	Speed Taps — 208–230 VOLTS		
	High	Med	Low †
0.1	1623	1509	1403
0.2	1583	1465	1357
0.3	1539	1420	1309
0.4	1494	1373	1260
0.5	1450	1326	1211
0.6	1399	1276	1159
0.7	1353	1223	1102

1. Values are with wet coil, no filter, and no heaters
 2. CFM Correction for dry coil = Add 3%
 3. † = Factory setting
 4. Low = Taps 1–3, Med = Tap 4, High = Tap 5
 5. In downflow applications, airflow must not exceed 1600 cfm due to condensate blowoff.

Table 10. Electrical Data

TEM4A0C42S41SB											
Heater Model No.	No. of Circuits/ Phases	240 Volt					208 Volt				
		Capacity		Heater Amps per Circuit	Minimum Circuit Ampacity	Maximum Overload Protection	Capacity		Heater Amps per Circuit	Minimum Circuit Ampacity	Maximum Overload Protection
		kW	BTUH				kW	BTUH			
No Heater				4.1 *	5	15			4.1 *	5	15
BAYHTR1504BRK BAYHTR1504LUG	1/1	3.84	13100	16.0	25	25	2.88	9800	13.8	22	25
BAYHTR1505BRK BAYHTR1505LUG	1/1	4.8	16400	20.0	30	30	3.6	12300	17.3	27	30
BAYHTR1508BRK BAYHTR1508LUG	1/1	7.68	26200	32.0	45	45	5.76	19700	27.7	40	40
BAYHTR1510BRK BAYHTR1510LUG	1/1	9.6	32800	40.0	55	60	7.2	24600	34.6	48	50
BAYHTR1517BRK- Circuit 1 (a)	2/1	9.6	32800	40.0	55	60	7.2	24600	34.6	48	50
BAYHTR1517BRK- Circuit 2		4.8	16400	20.0	25	25	3.6	12300	17.3	22	25
BAYHTR1523BRK- Circuit 1 (a)	2/1	9.6	32800	40.0	55	60	7.2	24600	34.6	48	50
BAYHTR1523BRK- Circuit 2		9.6	32800	40.0	50	50	7.2	24600	34.6	43	45
BAYHTR3510LUG	1/3	9.6	32800	23.1	33	35	7.2	24600	20.0	30	30
BAYHTR3517LUG	1/3	14.4	49200	34.6	48	50	10.8	36900	30.0	42	45

* = Motor Amps

(a) MCA and MOP for circuit 1 contains the motor amps.

Table 11. Air Flow Performance

TEM4A0C48S41SB			
EXTERNAL STATIC (in w.g)	AIRFLOW		
	Speed Taps — 208–230 VOLTS		
	High	Med	Low †
0.1	1784	1698	1634
0.2	1748	1662	1595
0.3	1715	1627	1559
0.4	1682	1591	1521
0.5	1650	1558	1488
0.6	1618	1525	1455
0.7	1499	1494	1422

1. Values are with wet coil, no filter, and no heaters
 2. CFM Correction for dry coil = Add 3%
 3. † = Factory setting
 4. Low = Taps 1–3, Med = Tap 4, High = Tap 5
 5. In downflow applications, airflow must not exceed 1600 cfm due to condensate blowoff.

Table 12. Electrical Data

TEM4A0C48S41SB											
Heater Model No.	No. of Circuits/ Phases	240 Volt					208 Volt				
		Capacity		Heater Amps per Circuit	Minimum Circuit Ampacity	Maximum Overload Protection	Capacity		Heater Amps per Circuit	Minimum Circuit Ampacity	Maximum Overload Protection
		kW	BTUH				kW	BTUH			
No Heater				6.0 *	8	15			6.0 *	8	15
BAYHTR1504BRK BAYHTR1504LUG	1/1	3.84	13100	16.0	28	30	2.88	9800	13.8	25	25
BAYHTR1505BRK BAYHTR1505LUG	1/1	4.8	16400	20.0	33	35	3.6	12300	17.3	29	30
BAYHTR1508BRK BAYHTR1508LUG	1/1	7.68	26200	32.0	48	50	5.76	19700	27.7	42	45
BAYHTR1510BRK BAYHTR1510LUG	1/1	9.6	32800	40.0	58	60	7.2	24600	34.6	51	60
BAYHTR1517BRK- Circuit 1 (a)	2/1	9.6	32800	40.0	58	60	7.2	24600	34.6	51	60
BAYHTR1517BRK- Circuit 2		4.8	16400	20.0	25	25	3.6	12300	17.3	22	25
BAYHTR1523BRK- Circuit 1 (a)	2/1	9.6	32800	40.0	58	60	7.2	24600	34.6	51	60
BAYHTR1523BRK- Circuit 2		9.6	32800	40.0	50	50	7.2	24600	34.6	43	45
BAYHTR1525BRK- Circuit 1 (a)	4/1	6.0	20500	25.0	39	40	4.5	15400	21.6	35	35
BAYHTR1525BRK- Circuit 2		6.0	20500	25.0	31	35	4.5	15400	21.6	27	30
BAYHTR1525BRK- Circuit 3		6.0	20500	25.0	31	35	4.5	15400	21.6	27	30
BAYHTR1525BRK- Circuit 4		6.0	20500	25.0	31	35	4.5	15400	21.6	27	30
BAYHTR3510LUG	1/3	9.6	32800	23.1	36	40	7.2	24600	20.0	32	35
BAYHTR3517LUG	1/3	14.4	49100	34.6	50	50	10.8	36900	30.0	44	45

* = Motor Amps

(a) MCA and MOP for circuit 1 contains the motor amps.

Performance and Electrical Data

Table 13. Air Flow Performance

TEM4A0C60S51SB			
EXTERNAL STATIC (in w.g)	AIRFLOW		
	Speed Taps — 208 – 230 VOLTS		
	High	Med †	Low
0.1	1954	1864	1780
0.2	1919	1827	1741
0.3	1885	1791	1704
0.4	1852	1756	1668
0.5	1821	1723	1633
0.6	1790	1691	1599
0.7	1761	1660	1567

1. Values are with wet coil, no filter, and no heaters
 2. CFM Correction for dry coil = Add 3%
 3. † = Factory Setting
 4. Low = Taps 1-3, Med = Tap 4, High = Tap 5
 5. BAYTEMDFKT1A must be used for downflow applications and airflow must not exceed 1800 cfm.

Table 14. Electrical Data

TEM4A0C60S51SB											
Heater Model No.	No. of Circuits/ Phases	240 Volt					208 Volt				
		Capacity		Heater Amps per Circuit	Minimum Circuit Ampacity	Maximum Overload Protection	Capacity		Heater Amps per Circuit	Minimum Circuit Ampacity	Maximum Overload Protection
		kW	BTUH				kW	BTUH			
No Heater				6.0 *	8	15			6.0 *	8	15
BAYHTR1504BRK BAYHTR1504LUG	1/1	3.84	1310-0	16.0	28	30	2.88	9800	13.8	25	25
BAYHTR1505BRK BAYHTR1505LUG	1/1	4.8	1640-0	20.0	33	35	3.6	12300	17.3	29	30
BAYHTR1508BRK BAYHTR1508LUG	1/1	7.68	2620-0	32.0	48	50	5.76	19700	27.7	42	45
BAYHTR1510BRK BAYHTR1510LUG	1/1	9.6	3280-0	40.0	58	60	7.2	24600	34.6	51	60
BAYHTR1517BRK- Circuit 1 (a)	2/1	9.6	3280-0	40.0	58	60	7.2	24600	34.6	51	60
BAYHTR1517BRK- Circuit 2		4.8	1640-0	20.0	25	25	3.6	12300	17.3	22	25
BAYHTR1523BRK- Circuit 1 (a)	2/1	9.6	3280-0	40.0	58	60	7.2	24600	34.6	51	60
BAYHTR1523BRK- Circuit 2		9.6	3280-0	40.0	50	50	7.2	24600	34.6	43	45
BAYHTR1525BRK- Circuit 1 (a)	4/1	6.0	2050-0	25.0	39	40	4.5	15400	21.6	35	35
BAYHTR1525BRK- Circuit 2		6.0	2050-0	25.0	31	35	4.5	15400	21.6	27	30
BAYHTR1525BRK- Circuit 3		6.0	2050-0	25.0	31	35	4.5	15400	21.6	27	30
BAYHTR1525BRK- Circuit 4		6.0	2050-0	25.0	31	35	4.5	15400	21.6	27	30
BAYHTR3510LUG	1/3	9.6	3280-0	23.1	36	40	7.2	24600	20.0	32	35
BAYHTR3517LUG	1/3	14.4	4910-0	34.6	50	50	10.8	36900	30.0	44	45

* = Motor Amps

(a) MCA and MOP for circuit 1 contains the motor amps.

Minimum Airflow CFM

TEM4A0B18S21SB, TEM4A0B24S21SB		
Heater	Minimum Heat Speed Tap	
	With Heat Pump	Without Heat Pump
BAYHTR1504BRK, BAYHTR1504LUG, BAYHTR1505BRK, BAYHTR1505LUG	Med	Low
BAYHTR1508BRK, BAYHTR1508LUG, BAYHTR1510BRK, BAYHTR1510LUG, BAYHTR3510LUG	Med	Low

TEM4A0B30S31SB, TEM4A0B36S31SB		
Heater	Minimum Heat Speed Tap	
	With Heat Pump	Without Heat Pump
BAYHTR1504BRK, BAYHTR1504LUG, BAYHTR1505BRK, BAYHTR1505LUG	Low	Low
BAYHTR1508BRK, BAYHTR1508LUG, BAYHTR1510BRK, BAYHTR1510LUG, BAYHTR3510LUG	Low	Low
BAYHTR1517BRK	Med	Low
BAYHTR3517LUG	High	Low

TEM4A0C37S31SB		
Heater	Minimum Heat Speed Tap	
	With Heat Pump	Without Heat Pump
BAYHTR1504BRK, BAYHTR1504LUG, BAYHTR1505BRK, BAYHTR1505LUG	Low	Low
BAYHTR1508BRK, BAYHTR1508LUG, BAYHTR1510BRK, BAYHTR1510LUG, BAYHTR3510LUG	Low	Low
BAYHTR1517BRK	Low	Low
BAYHTR1523BRK	High	High
BAYHTR3517LUG	Low	Low

TEM4A0C42S41SB		
Heater	Minimum Heat Speed Tap	
	With Heat Pump	Without Heat Pump
BAYHTR1504BRK, BAYHTR1504LUG, BAYHTR1505BRK, BAYHTR1505LUG	Low	Low
BAYHTR1508BRK, BAYHTR1508LUG, BAYHTR1510BRK, BAYHTR1510LUG, BAYHTR3510LUG	Low	Low
BAYHTR1517BRK	Low	Low
BAYHTR1523BRK	Med	Low
BAYHTR3517LUG	Low	Low

TEM4A0C48S41SB, TEM4A0C60S51SB		
Heater	Minimum Heat Speed Tap	
	With Heat Pump	Without Heat Pump
BAYHTR1504BRK, BAYHTR1504LUG, BAYHTR1505BRK, BAYHTR1505LUG	Low	Low
BAYHTR1508BRK, BAYHTR1508LUG, BAYHTR1510BRK, BAYHTR1510LUG, BAYHTR3510LUG	Low	Low
BAYHTR1517BRK	Low	Low
BAYHTR1523BRK	Med-Low	Med-Low
BAYHTR1525BRK	Med	Med-Low
BAYHTR3517LUG	Low	Low

Outline Drawing

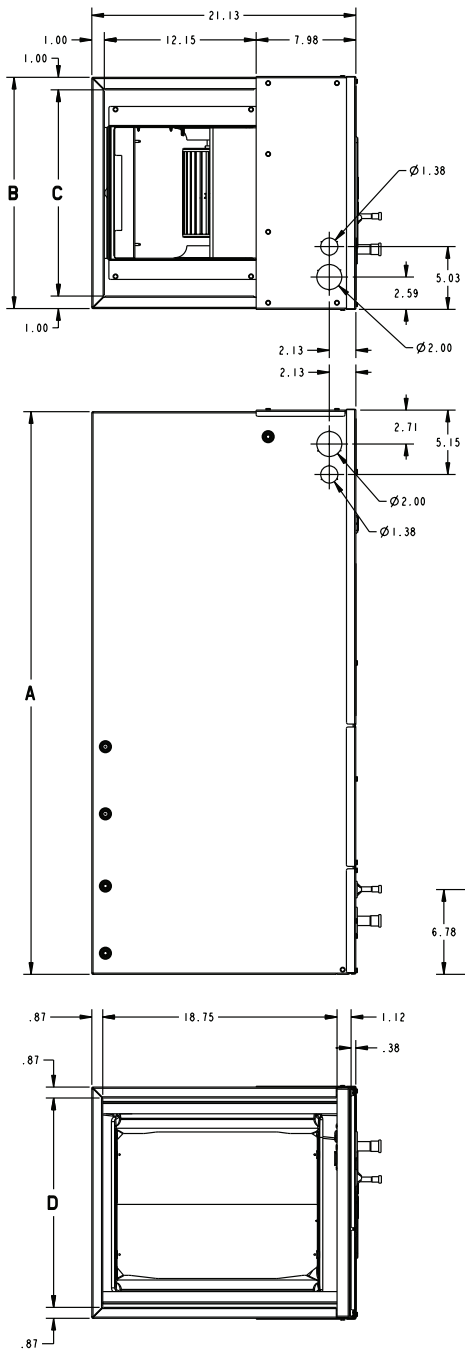

MINIMUM UNIT CLEARANCE TABLE	
	SERVICE CLEARANCE (RECOMMENDED)
SIDES	2"
FRONT	21"
BACK	0"
INLET DUCT	1"
OUTLET DUCT	N/A

NOTE: THIS UNIT IS APPROVED FOR INSTALLATION CLEARANCES TO COMBUSTIBLE MATERIAL AS STATED ON THE UNIT RATING NAMEPLATE

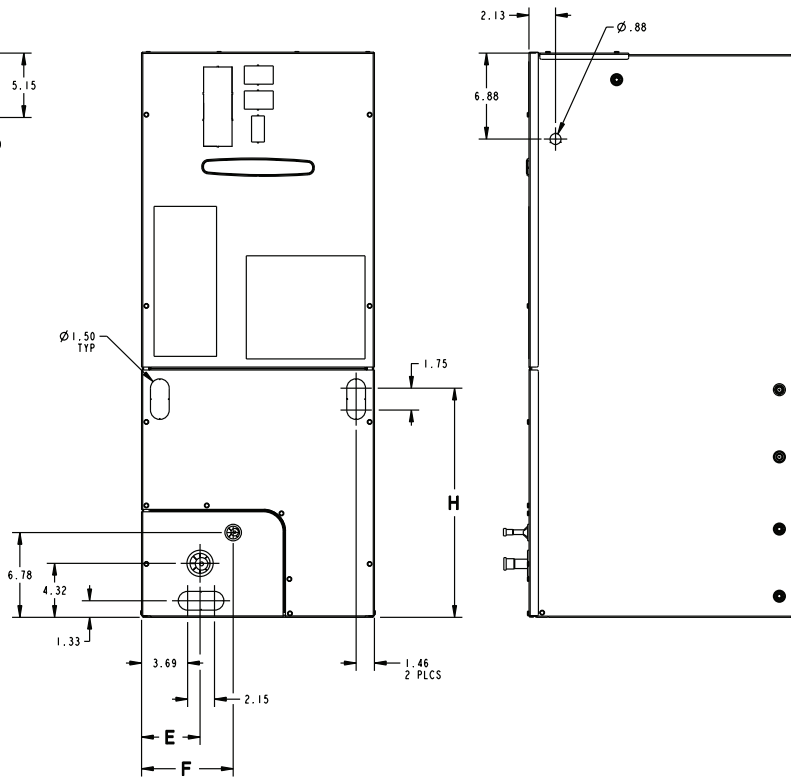

PRODUCT DIMENSIONS									
Air Handler Model	A	B	C	D	E	F	H	Flow Control	Gas Line Braze
TEM4A0B18, 24, 30, 36	45.02	18.50	16.50	16.75	4.68	7.33	18.34	TXV	3/4
TEM4A0C37, 42, 48, 60	51.27	23.50	21.50	21.75	7.01	9.66	24.59	TXV	7/8

All dimensions are in inches

Heater Pressure Drop Table

TEM Air Handler Models

Airflow CFM	Number of Racks				Heater Racks	
	1	2	3	4	Heater Model	No. of Racks
	Air Pressure Drop — Inches W.G.					
1800	0.02	0.04	0.06	0.14	BAYHTR1504	1
1700	0.02	0.04	0.06	0.14	BAYHTR1505	1
1600	0.02	0.04	0.06	0.13	BAYHTR1508	2
1500	0.02	0.04	0.06	0.12	BAYHTR1510	2
1400	0.02	0.04	0.06	0.12	BAYHTR3510	3
1300	0.02	0.04	0.05	0.11	BAYHTR1515	3
1200	0.01	0.04	0.05	0.10	BAYHTR1517	3
1100	0.01	0.03	0.05	0.09	BAYHTR3515	3
1000	0.01	0.03	0.04	0.09	BAYHTR3517	3
900	0.01	0.03	0.04	0.08	BAYHTR1519	4
800	0.01	0.03			BAYHTR1520	4
700	0.01	0.02			BAYHTR1521	4
600	0.01	0.02			BAYHTR1523	4
					BAYHTR1525	4

Coil Conversion Instructions

Table 15. Downflow

Important: Restrictions apply to Downflow applications.

1. For 2.5 ton downflow applications, airflow must not exceed 1200 cfm due to condensate blowoff.
2. For 3, 3.5 and 4 ton downflow applications, airflow must not exceed 1600 cfm due to condensate blowoff.
3. For 5 ton downflow applications, BAYTEMDFKT1A must be used at all times and airflow must not exceed 1800 cfm.

Follow the conversion steps when installing the air handler in downflow configuration.

1. Remove the front panels from the air handler. The coil and line set panel do not need to be separated.
2. Remove the two coil retaining brackets located at the front of the drain pan. Each is held in place by one screw. Discard brackets.
3. Remove the two screws holding the center horizontal brace and rotate out of place. Retain parts.

Figure 4.

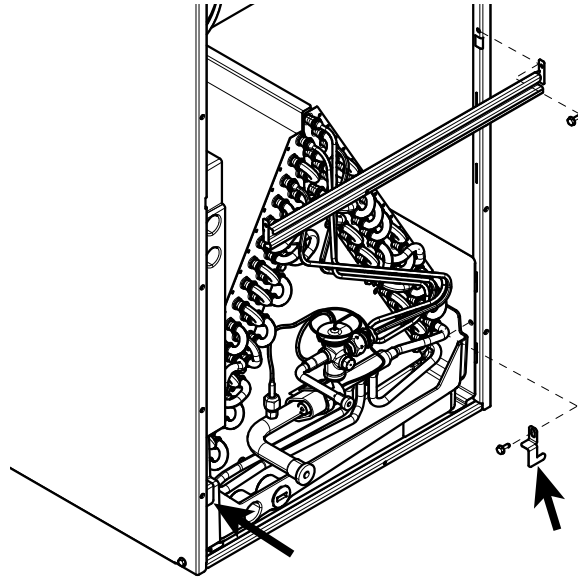

4. Slide the coil assembly out. Remove and discard the horizontal drain pan.

Figure 5. All other models

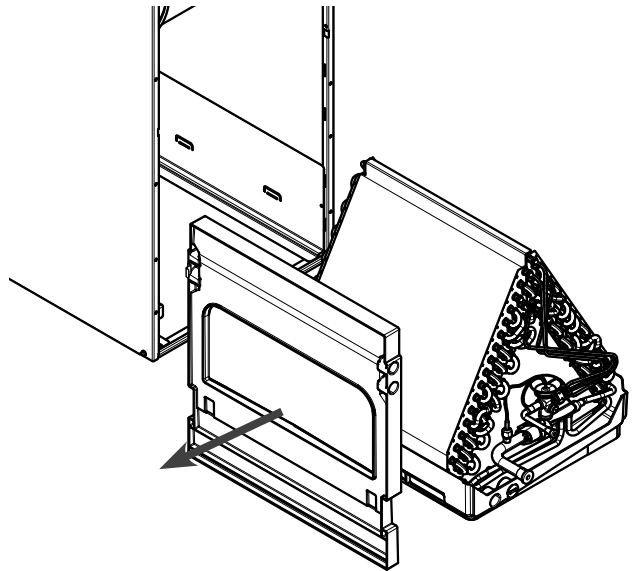
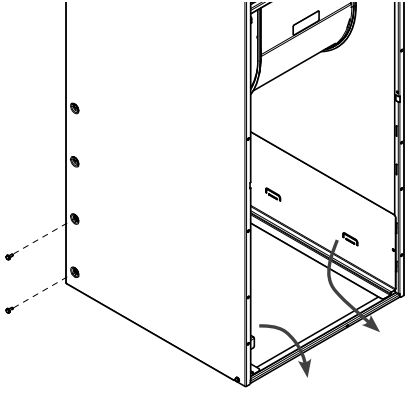
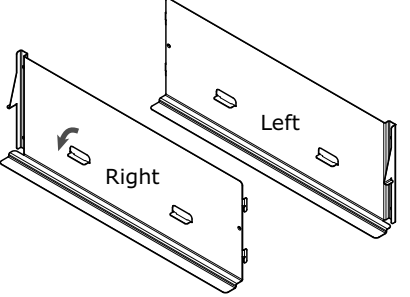
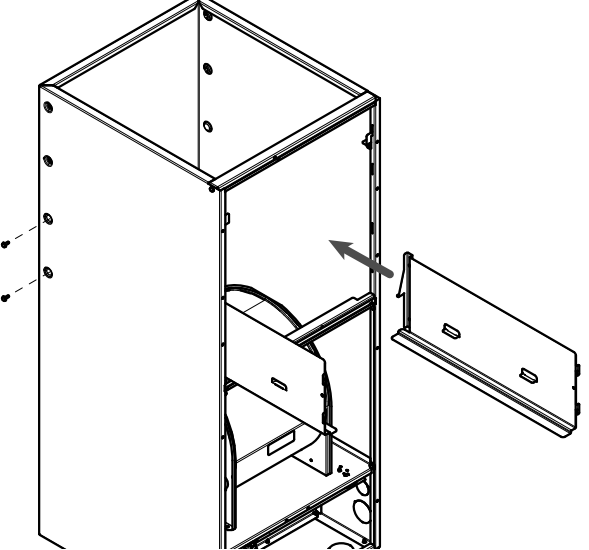
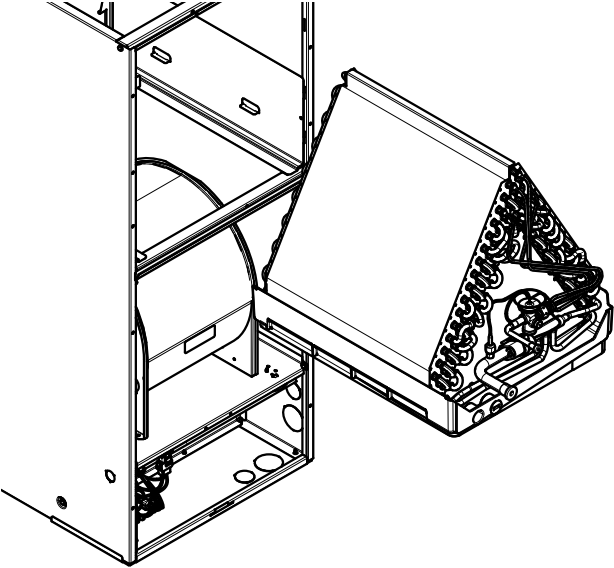
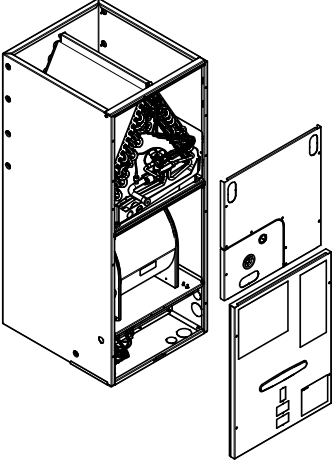

Table 15. Downflow (continued)

<ol style="list-style-type: none"> 5. On both sides of the cabinet, remove the two screws that hold the coil support brackets. Seal the holes to prevent air leakage. 6. Rotate and lift the two coil support brackets to remove from front slots in cabinet. 	<p>Figure 6. All models</p> 
<ol style="list-style-type: none"> 7. Bend the two tabs on each of the coil support brackets. Tabs should be bent inward so they are parallel to the bottom flange. 	<p>Figure 7. All models</p> 
<ol style="list-style-type: none"> 8. Rotate the unit into the downflow orientation. 9. Pre-drill four clearance holes in the cabinet at dimples located below the location the screws were removed for the coil support brackets. There are two holes per side. See location of holes 10. Replace the center horizontal bracket using the screws removed in a previous step. 11. Place coil support brackets into the lower set of slots and rotate into place. Push downward to lock into place. 12. Secure each bracket with 2 screws that were previously removed. 	<p>Figure 8. All models</p> 

Coil Conversion Instructions

Table 15. Downflow (continued)

<div data-bbox="407 296 545 432" data-label="Image"></div> <p data-bbox="167 436 786 485">BAYTEMDFKT1A downflow kit is required for the TEM4A0C60S51SA. Installation instructions are included with the kit.</p> <p data-bbox="155 562 792 621">13. Slide the coil assembly back into the air handler cabinet as shown 14. Remove the appropriate knock out for the condensate piping.</p>	<p data-bbox="1024 296 1268 317">Figure 9. All other models</p> 
<p data-bbox="155 968 358 989">15. Replace all panels</p>	<p data-bbox="1019 957 1273 978">Figure 10. All other models</p> 

Coil Conversion

Table 16. Horizontal Right

Follow the conversion steps when installing the air handler in horizontal right configuration.

1. Remove the front panels from the air handler. The coil and line set panel do not need to be separated.
2. Remove the two coil retaining brackets located at the front of the drain pan. Each is held in place by one screw. Save brackets and screws. [Figure 11, p. 23](#)
3. Remove the two screws holding the center horizontal brace and rotate out of place. Retain parts. [Figure 11, p. 23](#)

Figure 11.

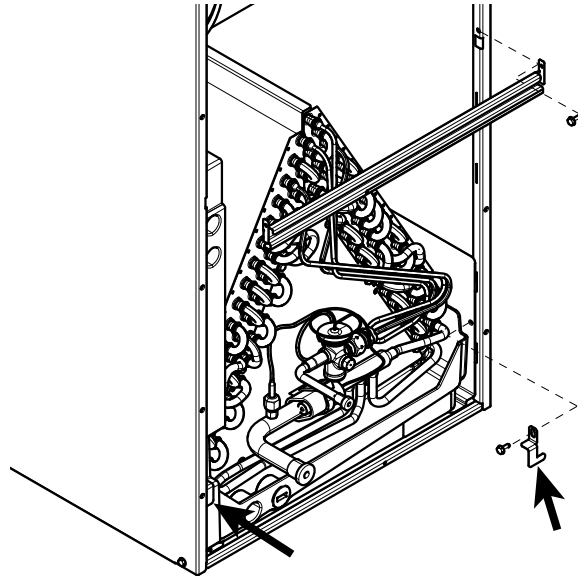

4. Make note of the horizontal drain pan orientation (up/down).
5. Slide the coil assembly out.
6. Change location of the water diverter bracket by removing the screws on the water diverter bracket that is located on the left side of the coil. Attach the water diverter to the right hand side of the coil using the same screws.

Important: The coil slabs are different and the mount hole locations will vary. See the illustrations on the following pages that correspond to the unit tonnage to see the correct mounting position of the water diverter bracket.

Important: The water diverter brackets are not symmetrical and will vary by tonnage.

Figure 12. All other models

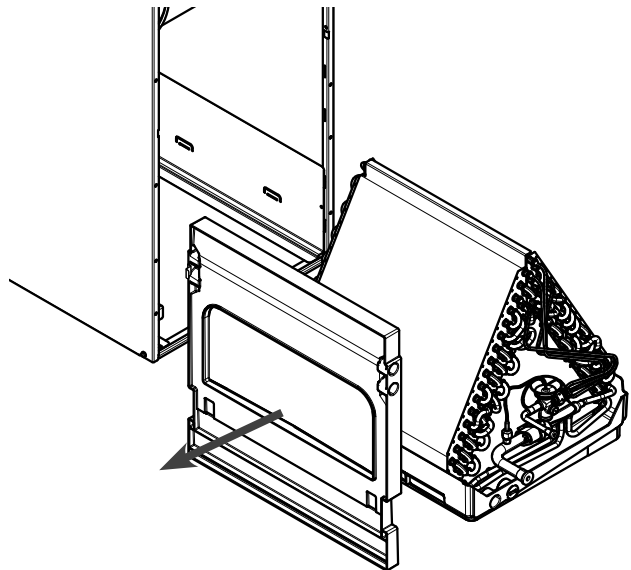

Coil Conversion Instructions

Table 16. Horizontal Right (continued)

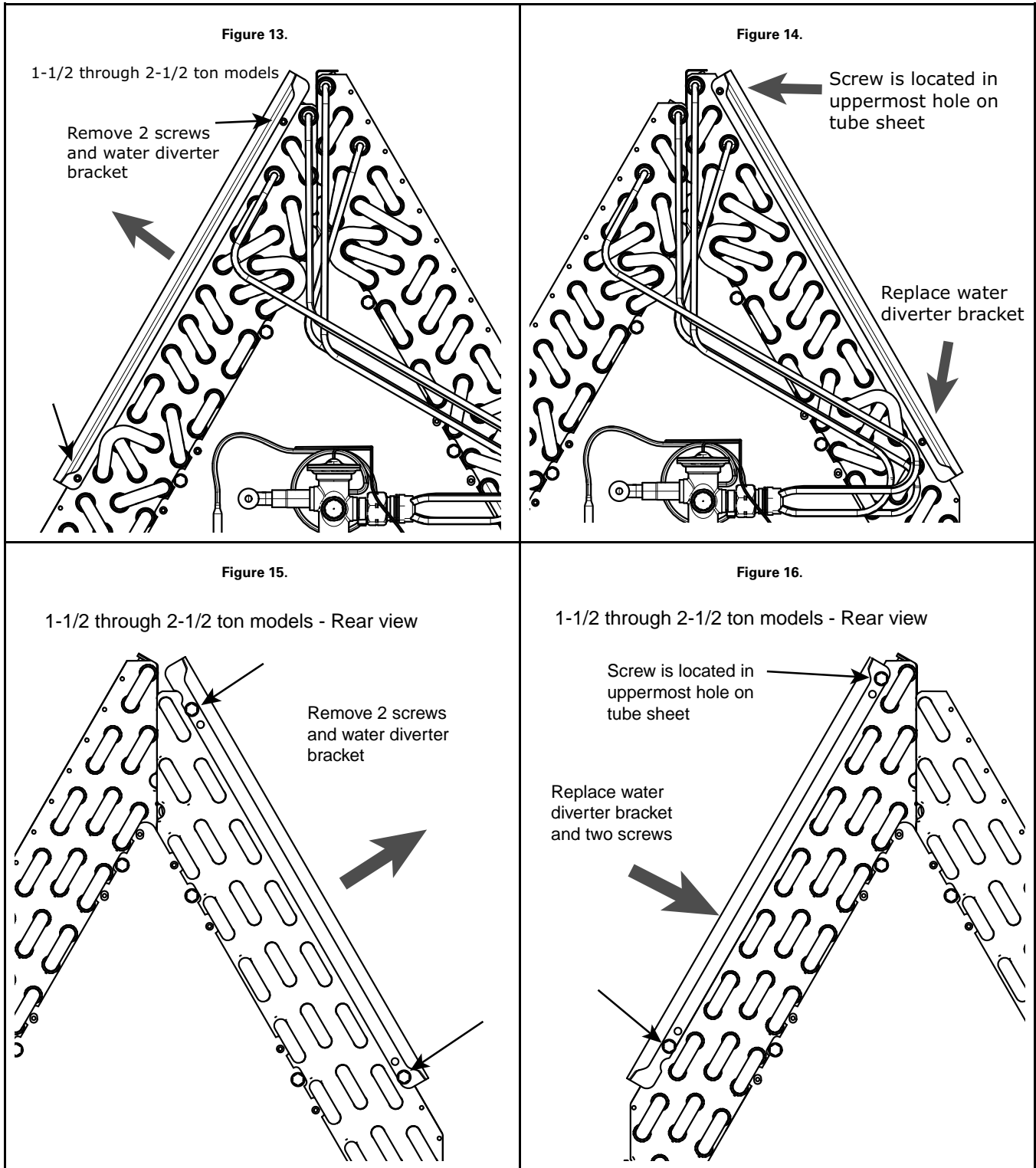
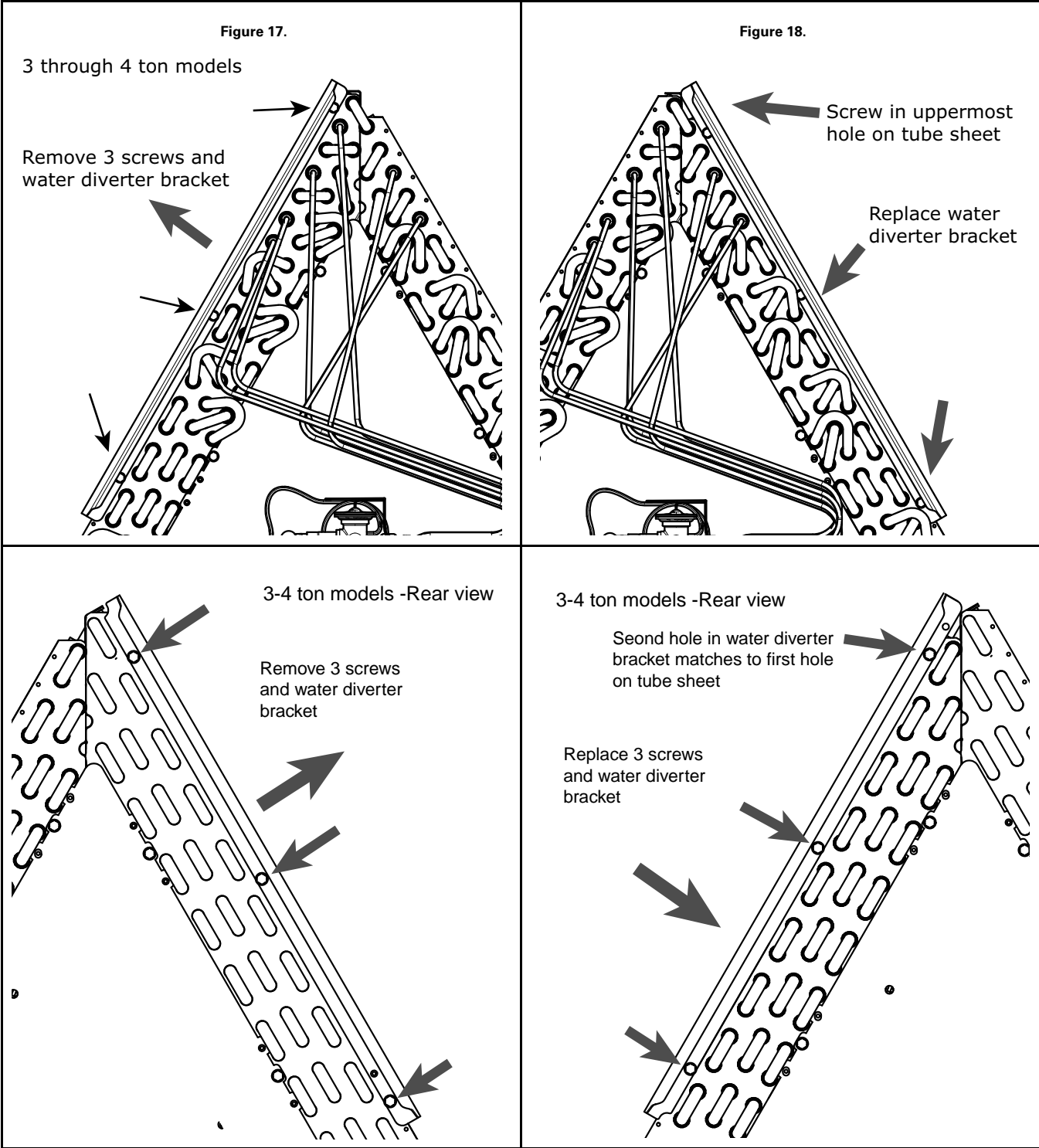

Table 16. Horizontal Right (continued)



Coil Conversion Instructions

Table 16. Horizontal Right (continued)

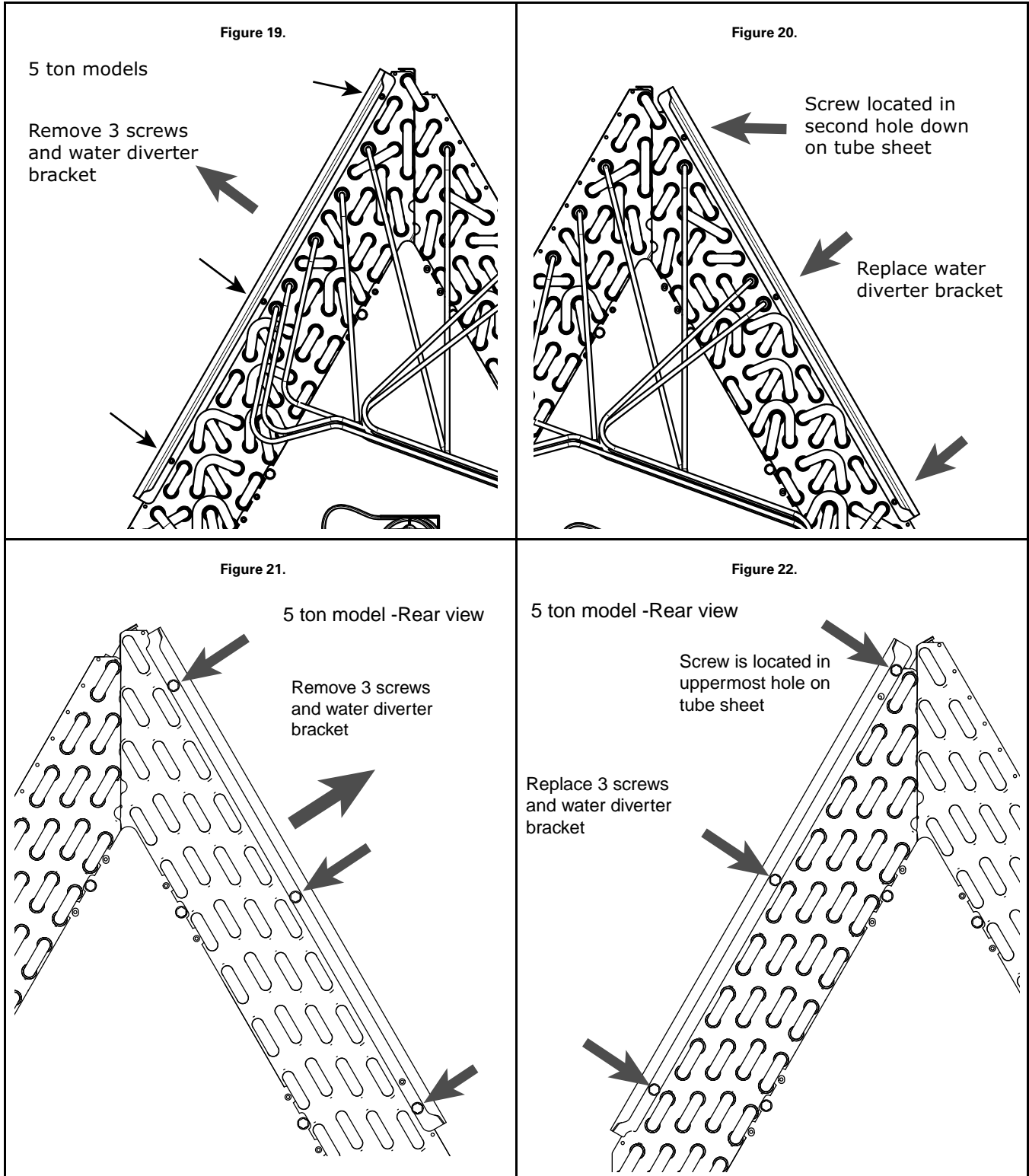
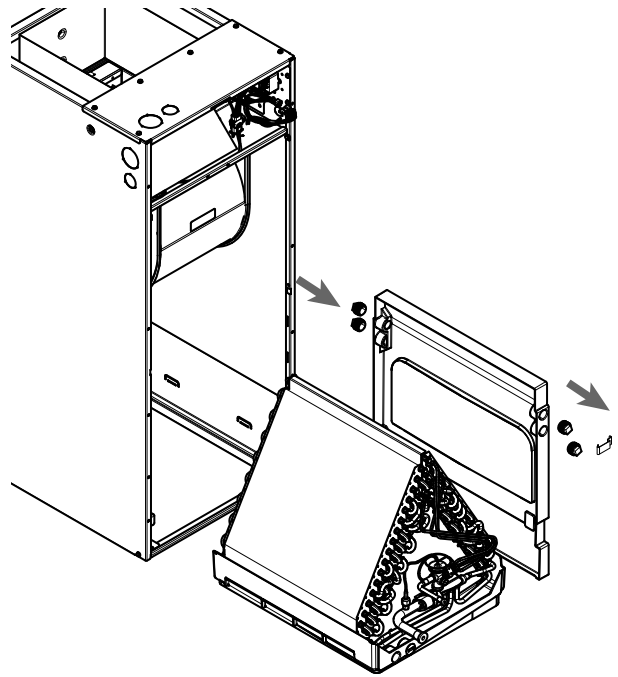

Table 16. Horizontal Right (continued)

7. Relocate the horizontal drain pan from the left side of the coil to the right side.
8. Remove the drain pan support bracket. Do not discard. Remove the two drain plugs from the front of the drain pan and insert them in the drains at the rear of the drain pan. [Figure 23, p. 27](#)

Figure 23. All other models



9. Reinstall the drain pan support bracket. The bracket should be located between the two drain plugs as shown in [Figure 24, p. 27](#)

Figure 24. All other models

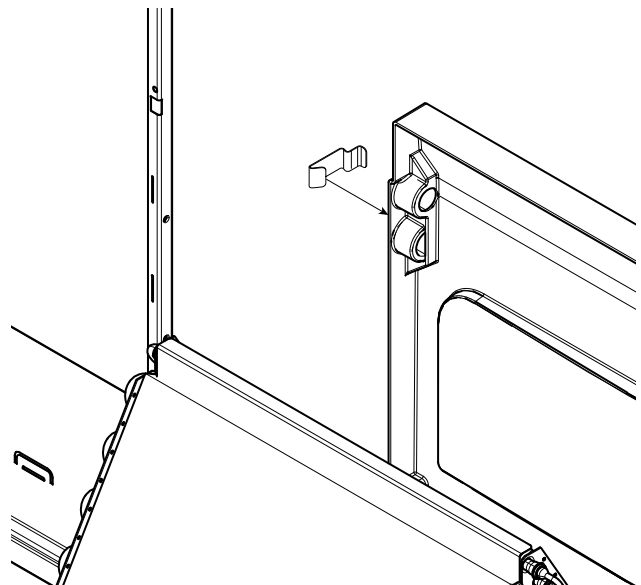

Coil Conversion Instructions

Table 16. Horizontal Right (continued)

10. Slide the coil assembly back into the air handler cabinet.
11. Replace the center horizontal brace removed in a previous step. See [Figure 4, p. 20](#)
12. Replace the two coil retaining brackets removed in a previous step. See [Figure 4, p. 20](#)
13. Replace the two coil retaining brackets removed in a previous step. See [Figure 25, p. 28](#)
14. Replace all panels.

Figure 25. All other models

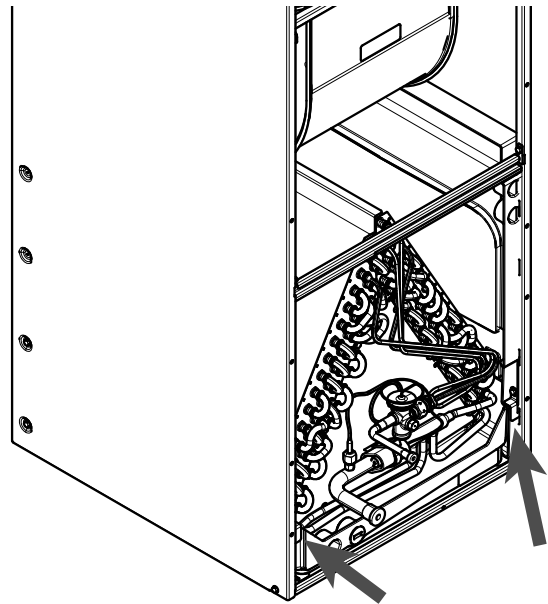

Checkout Procedures

The final phase of the installation is the system Checkout Procedures. The following list represents the most common items covered in a Checkout Procedure. Confirm all requirements in this document have been met.

<ul style="list-style-type: none"><input type="checkbox"/> All wiring connections are tight and properly secured.<input type="checkbox"/> Voltage and running current are within limits.<input type="checkbox"/> All refrigerant lines (internal and external to equipment) are isolated, secure, and not in direct contact with each other or structure.<input type="checkbox"/> All braze connections have been checked for leaks. A vacuum of 350 microns provides confirmation that the refrigeration system is leak free and dry.<input type="checkbox"/> Final unit inspection to confirm factory tubing has not shifted during shipment. Adjust tubing if necessary so tubes do not rub against each other or any component when unit runs.<input type="checkbox"/> Ductwork is sealed and insulated.<input type="checkbox"/> All drain lines are clear with joints properly sealed. Pour water into drain pan to confirm proper drainage. Provide enough water to ensure drain trap is primed.	<ul style="list-style-type: none"><input type="checkbox"/> Supply registers and return grilles are open, unobstructed, and air filter is installed.<input type="checkbox"/> Indoor blower and outdoor fan are operating smoothly and without obstruction.<input type="checkbox"/> Indoor blower motor set on correct speed setting to deliver required CFM. "Blower and fan set screws are tight."<input type="checkbox"/> Cover panels are in place and properly tightened.<input type="checkbox"/> For gas heating systems, manifold pressure has been checked and all gas line connections are tight and leak free.<input type="checkbox"/> For gas heating systems, flue gas is properly vented.<input type="checkbox"/> System functions safely and properly in all modes.<input type="checkbox"/> Owner has been instructed on use of system and given manual.
----------------------------------------------------------------------------------------------------------------------------------------------------------------------------------------------------------------------------------------------------------------------------------------------------------------------------------------------------------------------------------------------------------------------------------------------------------------------------------------------------------------------------------------------------------------------------------------------------------------------------------------------------------------------------------------------------------------------------------------------------------------------------------------------------------------------------------------------------------------------------------------------------------------------------------------------------------------------------------------------------------------------------------------------------------------------------	---------------------------------------------------------------------------------------------------------------------------------------------------------------------------------------------------------------------------------------------------------------------------------------------------------------------------------------------------------------------------------------------------------------------------------------------------------------------------------------------------------------------------------------------------------------------------------------------------------------------------------------------------------------------------------------------------------------------------------------------------------------------------------------------------------------------------------------------------------------------------------------------------------------------------------------------------



Ingersoll Rand (NYSE: IR) advances the quality of life by creating comfortable, sustainable and efficient environments. Our people and our family of brands — including Club Car®, Ingersoll Rand®, Thermo King® and Trane® — work together to enhance the quality and comfort of air in homes and buildings; transport and protect food and perishables; and increase industrial productivity and efficiency. We are a global business committed to a world of sustainable progress and enduring results.



ingersollrand.com



Ingersoll Rand has a policy of continuous product and product data improvements and reserves the right to change design and specifications without notice.
We are committed to using environmentally conscious print practices.