

MB

Product Specifications

MODULAR BLOWER CABINET

2, 3, 4, and 5 TONS

FEATURES

- Air conditioning ready
- Heat pump ready (no electric heat)
- Upflow, downflow, horizontal right or left applications
- Three speed PSC motor on all models
- Thermosetting powder coated steel cabinet
- 115V-1-60 supply voltage
- Matches with AC and HP cased coils

SERVICE

- Direct drive slide-out blower assembly

QUALITY

- Internally lined with ½ inch Tuf-Skin insulation

WARRANTY

- 5 year parts limited warranty



Model	Nominal Tons	Nominal CFM	Motor HP	Dimensions H x W x D in (mm)	Unit Weight lbs/kg	Ship Weight lbs/kg
MB080014C	2	800	1/3	24 x 14-3/16 x 20-1/2 (610 x 360 x 521)	54/25	58/26
MB120017C	3	1200	1/2	24 x 17-1/2 x 20-1/2 (610 x 445 x 521)	58/26	62/28
MB160021C	4	1600	1/2	25 x 21 x 20-1/2 (635 x 533 x 521)	70/32	75/34
MB200024C	5	2000	3/4	25 x 24-1/2 x 20-1/2 (635 x 622 x 521)	73/33	79/36

UNIT SPECIFICATIONS - BLOWERS

Model Number		MB080014C	MB120017C	MB160021C	MB200024C												
Application		Upflow / Downflow / Horizontal															
Electrical Data	Volt - Phase - Hz.	115 - 1 - 60															
	Minimum Circuit Ampacity	6.3	8.1	8.1	13.8												
	Time Delay Fuse (Amps)	15															
	Maximum Fuse or Breaker Size	15															
Blower Data	Size	DD10 - 7	DD10 - 8	DD10 - 8	DD10 - 9												
	Horsepower - Speed	1/3 - 3	1/2 - 3	1/2 - 3	3/4 - 3												
	Full Load Amps	5.0	6.5	6.5	11.0												
Transformer		(115 / 24 - VAC) 40 VA															
MB08	ESP in wc								MB16	ESP in wc							
SPEED	VOLTS	0.2	0.3	0.4	0.5	0.6	0.7	0.8	SPEED	VOLTS	0.2	0.3	0.4	0.5	0.6	0.7	0.8
Low	115v	1011	1015	1011	985	942	875	796	Low	115v	1046	1055	1055	1046	1034	1015	981
Med	115v	1241	1225	1202	1175	1135	1075	991	Med	115v	1369	1380	1384	1384	1368	1340	1300
High	115v	1387	1380	1372	1350	1311	1225	1119	High	115v	1718	1735	1750	1750	1736	1690	1634
MB12	ESP in wc								MB20	ESP in wc							
SPEED	VOLTS	0.2	0.3	0.4	0.5	0.6	0.7	0.8	SPEED	VOLTS	0.2	0.3	0.4	0.5	0.6	0.7	0.8
Low	115v	1037	1050	1058	1055	1041	1025	996	Low	115v	1397	1380	1366	1348	1321	1288	1235
Med	115v	1323	1340	1352	1355	1345	1320	1276	Med	115v	1796	1790	1777	1750	1705	1640	1554
High	115v	1671	1685	1696	1685	1651	1600	1531	High	115v	2336	2300	2255	2190	2106	1995	1873

Dimensions and Clearances – in (mm)

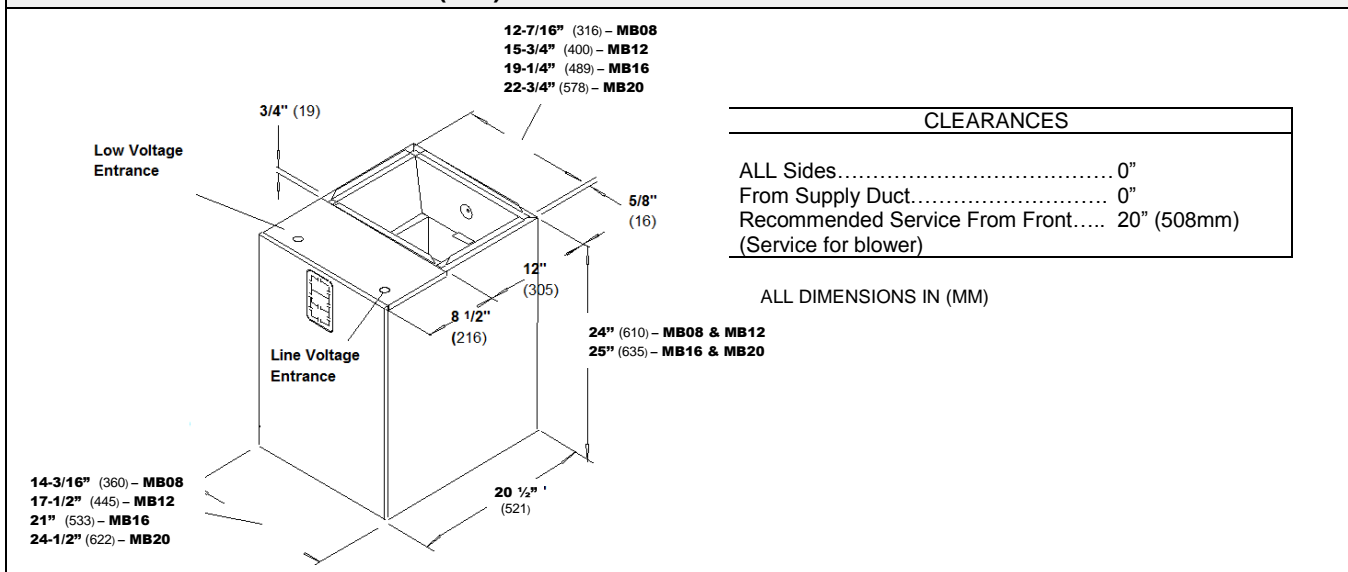

MODEL NUMBER IDENTIFICATION GUIDE

	1	2	3.4	5.6	7.8	9	10
	M	B	08	00	14	C	1
M = Cased Modular Blower							
V = Variable Speed ECM Motor - 208/230-1-60							
F = PSC Motor - 208/230-1-60							
B = PSC Motor - 115-1-60	TYPE						
08 = 800							
12 = 1200							
16 = 1600							
20 = 2000	NOMINAL MAX CFM						
00 = No Electric Heat	FACTORY INSTALLED ELECTRIC HEAT						
14 = 14.5"							
17 = 17.5"							
21 = 21"							
24 = 24.5"	CABINET WIDTH						
Sales Digit (Major Revision)							
Engineering Digit (Minor Revision)							

International Comfort Products, LLC
 Lewisburg, Tennessee 37091 U.S.A.